



VTB UNITED LEAGUE REGULATIONS

SEASON 2020-2021

REGULATIONS
OF VTB UNITED LEAGUE CHAMPIONSHIP
SEASON 2020-2021

APPROVED

By the Board of the League on July 14, 2020 with changes, approved by Board of the League on September 22, 2020



VTB UNITED LEAGUE REGULATIONS

SEASON 2020-2021

CONTENTS

TERMS AND DEFINITIONS.....	3
CHAPTER 1 GENERAL PROVISIONS.....	8
CHAPTER 2 CLUB LICENSING AND ITS PROCEDURE	20
CHAPTER 3 SPORTS FACILITIES. REQUIREMENTS FOR THE COURT AND TECHNICAL EQUIPMENT	24
CHAPTER 4 PLAYERS UNIFORM	36
CHAPTER 5 CHAMPIONSHIP SYSTEM, TIME AND VENUE, AWARD CEREMONIES.....	42
CHAPTER 6 CLUBS' OBLIGATIONS	49
CHAPTER 7 CHAMPIONSHIP REFEREEING	71
CHAPTER 8 INFORMATION AND STATISTICAL SUPPORT OF THE CHAMPIONSHIP	81
CHAPTER 9 CLUB PRESS SERVICE.....	84
MASS MEDIA (MEDIA).....	84
CHAPTER 10 TV SHOOTING OF CHAMPIONSHIP GAMES AND PRODUCTION OF TV SIGNAL.....	93
CHAPTER 11 SANCTIONS, PROTESTS AND DISCIPLINARY SANCTIONS.....	97
CHAPTER 12 MARKETING REQUIREMENTS IN CONNECTION WITH THE CHAMPIONSHIP. OTHER ACTIVITIES.	108
ANNEX	121



VTB UNITED LEAGUE REGULATIONS

SEASON 2020-2021

TERMS AND DEFINITIONS

Terms and definitions used in these Regulations shall have the following meanings:

- **Aggressive Behavior** – different actions of a person or a group of persons intended to inflict moral or other harm (except for physical harm) to another person without direct physical impact as well as infliction of damage to property of legal entities or individuals including physical impact.
- **Act of Violence** – physical impact of one person onto another expressed in the direct impact on another person's body: pushing, blows, beating, and various types of bodily injuries.
- **Fan** – a spectator who expressly demonstrates his/her favor to a certain team, whose behavior at the tribunes of sport facility is characterized by an active support of a certain team using club memorabilia before, during and after the game.
- **Entrance ticket, ticket, season ticket, invitation or documents replacing them** – a document of the form established by the Host Club, confirming the person's right to attend the Championship Games.
- **Directorate of VTB United League Championship or Directorate** – a working body established by General Director of the League that organizes, prepares, and hosts VTB United League Championship and controls fulfillment of the provisions of these Regulations, including sanctions and disciplinary measures against participants of VTB United League Championship.
- **Home game** – an official scheduled game of VTB United League Championship organized by a Host Club in a city and sports facility announced by this Club, excluding those provided for in these Regulations.
- **VTB United League or the League** – Autonomous Non-Profit Organization United Basketball League, a legal entity founded and acting under laws of the Russian Federation, an international basketball league officially recognized by FIBA, and a professional sports league pursuant to Federal Law of the Russian Federation No. 329-FZ dated December 4, 2007 “On Physical Culture and Sports in the Russian Federation”, the main goal of which is to organize and host a professional sport competition with the participation of professional basketball clubs of the Russian Federation and foreign states – VTB United League Championship.
- **Spectator** – an individual who is present at the venue of the Championship Game – a sports facility, with an admission ticket or a document replacing it, who is not a participant in the Game, is not associated with the organization of the Game and is not otherwise involved in the conduct of such a Game, including in providing public order and public safety during such a Game. For the purposes of these Regulations, the term “spectator” includes the term “fan”.
- **Player** – an athlete possessing required skills for playing basketball and participating in VTB United League Championship.
- **Foreign Club** – a professional basketball club participating in VTB United League Championship and located outside the Russian Federation. For the purpose of these Regulations, location is a place where a Foreign Club carries out its daily activities, in particular, but without limitation, a place where a Foreign Club hosts its Home Matches.
- **Schedule plan** – possible dates for the Championship, determined by the League on the basis of the schedule of sports events of the sports national basketball teams of the Russian Federation and other European basketball competitions. The schedule is approved by the League Council.
- **Games schedule** – dates and locations of Championship matches for each Club. The games schedule is prepared by the League together with the Clubs within the framework of the Calendar plan approved by the Council of the League and approved by the Directorate.



VTB UNITED LEAGUE REGULATIONS

SEASON 2020-2021

- **Club or Professional sport basketball club** – a legal entity established and acting under the laws of the country of its registration, conducting educational, training, competitive, fitness and instructional activities and having a basketball team participating in VTB United League Championship and having contractual relations with the League.
- **Guest Club** – a club participating in a Game on Host Club’s court.
- **Host Club** – a club participating in a Game on its own court and responsible for its organization and hosting.
- **Team** – a group of Players, Coaches, and Team Followers participating in the VTB United League Championship included in the Team Passport.
- **CYBL Team** – a basketball team formed within a Russian Club and participating in the CYBL Competition organized by the Russian Basketball Federation in accordance with its Regulations.
- **Licensing** – a procedure of admission to participate in the Championship, mandatory for all clubs, carried out by the League before the start of the Championship within the timeframes determined by the League.
- **License of Team Follower** – a document issued by the League, certifying affiliation of the team followers with the team. “TF” is the only category of a team follower license. Each license has a unique number that includes its category.
- **License of an Official – a document issued by the League, certifying the affiliation of an Official with the team.** “O” is the only category of an Official’s license. Each license has a unique number that includes its category.
- **Coach License** – a document issued by the League as a result of Licensing and enabling to fulfill duties of a Coach at the games of the VTB United League Championship. “C” is the only category of a Coach license. Each license has a unique number that includes its category.
- **Coach Assistant License** – a document issued by the League as a result of Licensing, giving the right to fulfill duties of a Coach Assistant at the games of VTB United League Championship. “C” is the only category of a Coach Assistant license. Each license has a unique number that includes its category.
- **Player License** – a document issued by the League as a result of Licensing, confirming a Player’s affiliation with a Team, and giving him or her the right to play for such Team in the VTB United League Championship. Player Licenses come in five categories: **N, Nn, F, U, and F/E**. Each license has a unique number that includes its category.
- **N Category License** entitles a Player to participate in VTB United League Championship and is issued to a Player who has the citizenship of the country for which he is playing, and who has the right to play for the national team of such a country in accordance with the provisions of FIBA Internal Regulations. Each license has a unique number that includes its category.
- **Nn Category License** entitles a Naturalized Player who had (has) citizenship of another state and after receiving citizenship of the Russian Federation is allowed to play for the national team of the Russian Federation in accordance with the provisions of FIBA Internal Regulations, to participate in the VTB United League Championships. Each license has a unique number including its category.
- **F Category License** entitles a Player to participate in VTB United League Championship and is issued to a Player (except for the Players of Russian Clubs who have citizenship of the Republic of Armenia, the Republic of Belarus, the Republic of Kazakhstan, the Kyrgyz Republic, who have the right to play for the sports teams of the Eurasian Economic Union), who has any citizenship and in accordance with the FIBA Internal Regulations is not entitled to play for the national team of the



VTB UNITED LEAGUE REGULATIONS

SEASON 2020-2021

country of the club for which he is declared. Each license has a unique number that includes its category.

- **F/E Category License** entitles a Player of a Russian Club to participate in European club championships except for VTB United League Championship without the right to participate in the Russian national championship and other Russian competitions. The license is issued solely to a Player of a Russian Club who is a citizen of any country and is not allowed to play for the national team of his/her Club's country of registration in accordance with the provisions of Internal regulations. Each license has a unique number that includes its category.
- **U Category License** entitles the Player of the Russian Club to participate in the VTB United League Championship and is issued to the Player of the Russian Club who has the citizenship of the Republic of Armenia, the Republic of Belarus, the Republic of Kazakhstan, the Kyrgyz Republic, which have the right to play for the sports teams of the member states of the Eurasian Economic Union.
- **Match or Game** means a basketball match in the framework of VTB United League Championship.
- **Youth Championship** – Russian National Junior Competition U21 that is mandatory for participation for Russian Clubs, participants of VTB United League Championship.
- **Youth Team** – a basketball team formed in a Russian Club and participating in the Russian National Junior Championships U21.
- **Naturalized Player** – a Player who had (has) citizenship of other state and who is allowed to play for the national team of the Russian Federation in accordance with the provisions of FIBA Internal Regulations after being accepted as a citizen of the Russian Federation (**Nn License**).
- **National Centre of Sports Arbitration (NCSA)** – permanent arbitration institution (PAI) acting under Autonomous Non-Commercial Organization “Sports Arbitration Chamber”, conducting administrative activity on arbitration (arbitration proceedings) of disputes in high performances sport including individual labor disputes in accordance with Federal Law 382-FZ of December 29, 2015 “On Arbitration (arbitration proceedings) in the Russian Federation”, Federal Law 329-FZ of December 4, 2007 “On Physical Education and Sport in the Russian Federation”, Statute of Autonomous Non-Commercial Organization “Sports Arbitration Chamber”, other NCSA regulatory legal acts and rules.
- **Main Team** is a team of a Club participating in the Championship.
- **Club Officials – individuals** authorized to represent interests of a Club and/or Team (President, Vice-President, Director General, General Manager, Executive Director, Deputy Director General, Press-officer, etc.) in accordance with the Statute or power of attorney (**O License**).
- **Official Delegate-Inspector** – a person appointed by the Directorate and fulfilling its duties in accordance with these Regulations.
- **Official ball** – a basketball ball approved by FIBA and designated as a playing Championship ball by the League.
- **FIBA Official Basketball Rules** – a document approved by FIBA, which contains the rules of basketball, taking into account all official appendices, changes, clarifications, additions and interpretations for individual articles of the FIBA Official Basketball Rules, including the FIBA Official Basketball Rules – Basketball Equipment.
- **FIBA Official Basketball Rules – Basketball Equipment** – an annex to the FIBA Official Basketball Rules, approved by FIBA, containing requirements for sports facilities and equipment for playing basketball.



VTB UNITED LEAGUE REGULATIONS

SEASON 2020-2021

- **Team Passport** – a document issued by the League and containing a list of Players, Coaches, Coaches' Assistants, Team Followers and Officials by name and surname, playing number (for players), positions (for Team Followers and Officials), license numbers.
- **Coach Assistant** – an individual assisting a Coach in the fulfillment of his or her professional duties and authorized to replace him/her even during the game in case a Coach is unable to continue to fulfill its duties (**C License**).
- **Team Representative at the Match** – an individual included in the Technical entry form for the Match from among the persons representing the interests of the team at this Match (**TF license**).
- **Control of Referees** – a working body created to control quality of the Referees during VTB United League Championship.
- **Regulations** – League regulatory document that determines order and terms of participation of basketball clubs, players, coaches, officials, team followers, referees, commissioners, table officials, official delegates-inspectors and other persons in VTB United League Championship.
- **Russian Club** – a professional sports basketball club participating in VTB United League Championship and located in the Russian Federation. For the purpose of these Regulations, location shall mean a place where a Russian Club carries out its daily activities, in particular, but without limitation, a place where a Russian Club hosts its Home Games.
- **RBF** – All-Russian Public Organization Russian Basketball Federation, a legal entity founded and acting under the laws of the Russian Federation, accredited by the federal executive body for physical education and sports, member of FIBA and Russian National Olympic Committee.
- **Sanctions (sports sanctions, disciplinary sanctions, penalties)** – responsibility for violation of existing official FIBA basketball rules, present Regulations, other regulatory documents and decisions taken by FIBA, League and/or Directorate by participants of the Championships.
- **Sector of active support** – a special block of spectators' seats in a sports facility designated for supporters of the Host Club and a separate block of seats for supporters of the visiting Club designated by the Host Club in agreement with League for supporters of the Championships including mass media.
- **Mass media** – mass-media communications.
- **Board of the League** – a collective supreme governing body formed for a period of one (1) year from representatives of basketball clubs (one from each club) participating in the VTB United League Championship, representatives of the basketball federations of the countries (one from each country), whose teams take part in the VTB United League Championships. The Board of the League includes Honorary President of the League, funders of the League, one representative of the Title Sponsor of the VTB United League Championships.
- **Team Followers** – persons included into the Team Passport and fulfilling functional duties in a Team and allowed to sit on the Team bench during a Game (**TF License**).
- **Sponsor** – a legal entity or an individual who provides funding, products, or services in return of advertising, marketing, and other services.
- **Court of Arbitration for Sport (CAS) (fr. Tribunal Arbitral du Sport, TAS) based in Lausanne, Switzerland** – an international arbitration body aimed at solving disputes related to sport.
- **Sport Disqualification/Disqualification** – a sanction in a form of exclusion from participation in VTB United League Championship imposed by the Directorate for the violation of these Regulations.
- **Athlete** – an individual who takes part in a selected sport or sports and participates in Sports Competitions.



VTB UNITED LEAGUE REGULATIONS

SEASON 2020-2021

- **Sports Facility** – construction/engineering facility, suitable for staging basketball games of the Championships and meeting Official FIBA Rules and provisions of these Regulations, including playing court and tribunes for spectators.
- **Means of support** – items containing information or graphic data, materials for visual decoration of tribune as well as devices for generating sounds that can be used by spectators, with the exception of items the use of which is prohibited by the laws of the country in which the Match takes place and these Regulations.
- **Referee, Commissioner** – individuals possessing relevant passports/licenses of RBF or FIBA and fulfilling their duties in accordance with FIBA Official Basketball Rules.
- **Match Technical Entry** – Players, Coaches and Team followers, indicating the surname and first name, playing number (for Players), position (for Team followers), license numbers entered in the Team Passport and entitled to take part in a specific Championship Match.
- **Coach** – a individual professionally conducting training of players as well as managing the team for reaching sports results in the Championship (**C License**).
- **Participants of the Championship** – individuals participating in a Championship Game/Match, including Players, Coaches, Coach Assistants, medical staff, Referees, Commissioners, Delegates Inspectors, Table Officials and other persons obliged to participate in accordance with FIBA Official Basketball Rules and these Regulations.
- **Farm Team** – a basketball team formed within a Russian Club and participating in the Russian Basketball Championship organized by the RBF in accordance with its Regulations among Super League men’s clubs/teams of the I or II divisions.
- **FIBA** – the International Basketball Association recognized by the International Olympic Committee. FIBA is a member of the General Association of International Sports Federations.
- **FIBA Europe** – one of the five FIBA departments in charge of developing basketball in Europe.
- **VTB United League Championship (or the Championship)** – an international professional sport basketball competition with the participation of Russian and foreign professional basketball clubs organized and held by the League in accordance with these Regulations, including the combination of and each individual Game of the 2020–2021 season of VTB United League Championship, consisting of two (2) stages: Stage 1 is the Regular Championship in which all admitted Teams are allowed to participate; Stage 2 is the Play-Off, which features the eight (8) best teams from the regular season, and serves to decide the winner.
- **Russian National Championship** – Russian National Basketball Championship “United League” 2020–2021 among men’s teams of Sports Clubs, organized by RBF. The rights to host the Russian National Championship are delegated to the League.

All terms and definitions listed in these Regulations may be used both in singular and plural without prejudice for their meaning.

All terms and definitions contained in these Regulations have been composed for convenience only and will not influence legal authority of any provisions of these Regulations.



VTB UNITED LEAGUE REGULATIONS

SEASON 2020-2021

CHAPTER 1

GENERAL TERMS

ARTICLE 1 GOALS OF THE CHAMPIONSHIP

1.1 The Championship has the following goals:

- to determine the winner and runner-ups of the Championship (for Clubs) and Russian National Championship (for Russian Clubs) in accordance with sport principles;
- to classify clubs in the Championship (for Clubs) and Russian National Championships (for Russian Clubs);
- to develop and promote basketball;
- to develop sport reserve;
- to improve skills of basketball players;
- to promote physical education, sport, and healthy lifestyle.

ARTICLE 2 RIGHTS FOR ORGANIZATION AND HOSTING OF THE CHAMPIONSHIP

2.1 In accordance with the Statutes of the League, Articles 19.2 and 20 of Federal Law No. 329-FZ of December 4, 2007 “On Physical Education and Sport in the Russia Federation”, Championship is organized by the League, which means that the League determine terms of staging and take responsibility for its organization and staging and approve its results.

2.2 Russian National Championship is organized by RBF. Pursuant to clause 16 of Federal Law No. 329-FZ dated December 4, 2007 “On Physical Culture and Sports in the Russian Federation” and a contract with the League dated September 30, 2015 RBF has delegated the hosting of Russian National Championship to the League.

The participation of Russian Clubs in the Championship is considered as participation in the Russian National Championship, and sport results shown by such Clubs in the Championship are used to determine the winner of the title of the Russian National Champion.

2.3 The League possesses exclusive rights for the organization and hosting of the Championship.

2.4 The League is a sole owner of property and non-property rights for the Championship including, without limitation:

2.4.1 Exclusive rights to use the name of the Championship and its symbols, to place the advertisements of goods, work, and services at the places of hosting of the Games of the Championship, as well as other rights to use the name of the Championship and its symbols related to its status of the host of the Championship;

2.4.2 Exclusive rights to cover the Championship by means of broadcasting video and/or audio recordings by any means and/or using any technologies as well as by means of recording broadcasts and/or photo shoots of the Championship, as well as other rights to cover the Championship related to its status of the host of the Championship.

All exclusive rights that belong to the League may be used by third persons only upon the League’s authorization or on the basis of written agreements on the acquisition of such rights, or in the order set out by these Regulations.

Being the host of the Championship and the owner of all property and moral rights for it, the League is entitled, without limitation:

- to approve these Regulations at the Board of the League;



VTB UNITED LEAGUE REGULATIONS

SEASON 2020-2021

- to interpret the provisions of these Regulations if required and to resolve any disputes that arise due to the organization and hosting of the Championship;
- development by the Directorate of decisions and/or recommendations that are mandatory for the Clubs participating in the Championship, aimed at ensuring the safety of the life and health of Players, Coaches, Officials and Team Followers of the Club, other championship participants, as well as spectators, including in order to prevent and exclude the spread of a new coronavirus infection (COVID-19), or other infection that may be declared an epidemic or pandemic, during the Championship, taking into account the requirements of federal and local authorities of the Russian Federation and authorities of Foreign Clubs (for example, on holding Games without spectators, on testing for coronavirus infection, on admission to the Games subject to testing for coronavirus infection, on the use of antiseptics, medical and other protective face masks, on observing the distance between individuals, on contactless temperature control in sports facilities, on the disinfection of the premises of a sports facility, etc.). Such decisions and/or recommendations may be made by the Directorate individually for each participating club, taking into account the epidemiological situation in the city/country of such a Club and the requirements of Federal and local authorities of the Russian Federation and/or authorities of Foreign Clubs at a specific time;
- to bring Clubs, Players, Coaches, Team Followers, Officials, and other persons to liability for the violation of the provisions of these Regulations;
- to determine the results of Games and the Championship in general;
- to provide Referees for the Games of the Championship;
- to use any advertising opportunities during Games of the Championship, organize any advertising, promotion activities during Games of the Championships, other League events, grant official statuses and titles to sponsors (partners, advertisers) of the Championship.

2.5 Clubs – participants of the Championship in accordance with Federal Law No. 329-FZ of December 4, 2007 “On Physical Education and Sport in the Russian Federation” and present Regulations are co-organizers of home matches of the Championships. Participation of Clubs in the Championships is arranged according to the list of participants approved by the Board of the League and a contract concluded with the League.

2.6 Clubs undertake the following obligations, which serve as a compulsory prerequisite for participation of their Teams/Clubs in the Championship:

- to enter into a relevant contract with a Sports Facility to host Games of the Championships and to secure its fulfillment at the Club’s own cost, including all material, technical, financial, organizational, and safety issues related to Games and proper use of the Sports Facility in accordance with the provisions of these Regulations;
- in order to ensure the safety of life and health of Players, Coaches, Officials and Team Followers of the Club, other participants of the Championship, as well as spectators, comply with the sanitary and hygienic standards, sanitary and epidemiological rules and requirements imposed by Federal and local authorities of the Russian Federation and authorities of Foreign Clubs, including for the prevention of new coronavirus infection (COVID-19);
- promptly respond to changes in the epidemiological situation, including in connection with the spread of a new coronavirus infection (COVID-19), as well as follow the recommendations and follow the mandatory instructions of the authorities and the League on the organization and conduct of regular hygiene measures, disinfection, general cleaning and other hygiene measures in the premises of a sports facility where Championship matches and team training will be held (including the use of antiseptics, medical and other protective face masks, keeping distances



VTB UNITED LEAGUE REGULATIONS

SEASON 2020-2021

between individuals, contactless temperature control in sports facilities, holding Matches without spectators);

- immediately inform the League of circumstances that may cause harm to the life and health of Players, Coaches, Officials and Team Followers of the Club, other participants of the Championship and spectators, as well as of decisions taken by the authorities that may affect the conduct of Championship Matches;
- conduct anti-epidemic and other measures imposed by Federal and local authorities of the Russian Federation and authorities of countries of Foreign Clubs in order to prevent possible threats to the life and health of Players, Coaches, Officials and Team Followers of the Club, other participants of the Championship and spectators;
- comply with the decisions and/or recommendations of the Directorate to ensure safety of the life and health of Players, Coaches, Officials and Team Followers of the Club, other championship participants, as well as spectators, including in order to prevent and exclude the spread of a new coronavirus infection (COVID-19) during the Championship (for example, on holding Games without spectators, on testing for coronavirus infection, on admission to the Games subject to testing for coronavirus infection, on the use of antiseptics, medical and other protective face masks, on observing the distance between individuals, on contactless temperature control in sports facilities, on the disinfection of the premises of a sports facility, etc.). Such decisions and/or recommendations may be made by the Directorate individually for each participating club, taking into account the epidemiological situation in the city/country of such a Club and the requirements of Federal and local authorities of the Russian Federation and/or authorities of Foreign Clubs at a specific time;
- to conclude labor and other agreements with Players, Coaches and Team Followers;
- to secure organization of training sessions and participation of Players, Coaches and Team Followers in the Games of the Championship;
- to insure Players against accidents during sport season and conclude agreements between the Club and a medical institution aimed at preliminary and regular medical check-ups of the Club Players and provision of other medical services to them, issuing a compulsory medical conclusion on Players' health and their access to training and Games of the Championships, including in accordance with the recommendations of the Federal and local authorities of the Russian Federation and/or government authorities of countries of foreign clubs and/or Directorate to conduct periodic, including pre-match player testing other persons of the Club having a new coronavirus infection (COVID-19) to avoid the spread of such infections;
- to secure the implementation of the League's exclusive rights for the placement of advertisements of goods, works, and services at the places where the Games of the Championship take place in accordance with the provision of these Regulations;
- to participate in the accreditation of reporters and granting them access to the Games of the Championship;
- to hold ceremonies during the Games of the Championship in accordance with the procedure and content of such ceremonies set out by the League;
- to produce and sell tickets to Regular Championship and Play-Off games;
- to carry out other actions in order to prove the status of a participant of the Championship and a co-host of Home Games of the Championship in accordance with the provisions of these Regulations.



VTB UNITED LEAGUE REGULATIONS

SEASON 2020-2021

ARTICLE 3 RULES OF THE CHAMPIONSHIP

- 3.1** The Championship is carried out in accordance with FIBA Official Basketball Rules as amended, clarified, supplemented and interpreted in individual articles, as well as in accordance with these Regulations and Annexes to it that form its integral parts. Clubs participating in the Championship are obliged to follow the League Statutes, the present Regulations, Directorate decisions, FIBA regulating documents (i.e. FIBA Code of Ethics, Rules on international transfers, Rules on players' agents) and RBF regulating documents (only for Russian Clubs, in particular, "Player's Status", "Rules regulating activity of players' agents in the RBF").
- 3.2** These Regulations and all Annexes to it are agreed and approved by the Board of the League and may be amended upon decision of the Board.
- 3.3** All participants of the Championship, including Players, Coaches, Coach Assistants, managers, Officials, Club specialists, as well as Referees, Delegated Inspectors, Commissioners, and other persons involved with the Games of the Championship should be familiarized with and follow FIBA Official Basketball Rules, the Code of the World Anti-Doping Agency (WADA), Federal Law of the Russian Federation No. 329-FZ dated December 4, 2007 "On Physical Culture and Sports in the Russian Federation", All-Russian Anti-Doping Rules, and the provisions of these Regulations.
- 3.4** Illegal influence on the results of the Games of the Championship, as well as the participation of Players, Referees, Coaches, Team managers, and other participants of the Championship in gambling at bookmaker's offices and betting houses at the results of the Games of the Championship is prohibited in accordance with the provisions of clause 26.2 of Federal Law of the Russian Federation No. 329-FZ dated December 4, 2007 "On Physical Culture and Sports in the Russian Federation".
In case of violation of this provision and illegal influence on the results of the Games of the Championship or the participation of Players, Referees, Coaches, Commissioners, Team managers, and other participants of the Championship in gambling at bookmaker's offices and betting houses at the results of the Games of the Championship a **fine in the amount from one hundred thousand (100,000) RUB to one million (1,000,000) RUB** is imposed on a guilty person, and/or such a person is disqualified for a period from one year to perpetual period of time. **The Directorate shall be entitled to charge an additional fine from a guilty person that violates the prohibitions set out in this paragraph.**
- 3.5** The Players of the Teams participating in the Championship may be subject to doping control. In the course of doping control Players, Clubs, and other participants of the procedure are guided by the Code of the World Anti-Doping Agency (WADA), FIBA Internal Anti-Doping Regulation, and All-Russian Anti-Doping Rules.

ARTICLE 4 MANAGEMENT OF ORGANIZATION AND HOSTING OF THE CHAMPIONSHIP. OFFICIAL LANGUAGE

- 4.1** The organization and hosting of the Championship are managed by the Directorate. The composition of the Directorate is approved by the Director General of the League.
- 4.2** The League and the Directorate are located at 6 Presnenskaya Embankment, bld. 2, Imperiya Business Center, office 4007, Moscow, 123317
Phone: +7 (495) 966-44-45
E-mail: office@united-league.com
Official web-site: <http://www.vtb-league.com>.



VTB UNITED LEAGUE REGULATIONS

SEASON 2020-2021

- 4.3** All and any payments that should be made to the League in accordance with these Regulations are made using the following bank details:
ANO United Basketball League
Legal/actual address:
6 Presnenskaya Embankment, bld. 2, office 4007, Moscow, 123317
OGRN 1097799001398
INN 7704275692 KPP 770301001
S/a 40703810200000011416 at
VTB Bank (PJSC), Moscow, branch 7701
c/a 30101810345250000745 BIC 044525745
- 4.4** The official language of the Championship, the League, and the Directorate is Russian.
- 4.5** Foreign Clubs may use the English language, including in the official documents sent to the League. In case a Foreign Club sends to the League official documents in its language, it should enclose a translation of such documents into English or Russian sealed and signed by the head of the Foreign Club.
- 4.6** In the course of construction of these Regulations, decisions of the Directorate and relevant documents the wording in Russian shall prevail.

ARTICLE 5 RIGHTS OF THE DIRECTORATE

- 5.1** The Directorate is authorized to make decisions on any issues covered by these Regulations including imposition of sanctions. In case a situation cannot be resolved based on provisions of these Regulations, including sanctions for violation not covered by these Regulations, the Directorate is entitled to take a decision with the following notification of such decisions. Such decisions are binding for all participants of the Championship.

In case of non-fulfillment of the Directorate's decisions, a fine from one hundred thousand (100,000) to five hundred thousand (500,000) RUB is imposed on a Club upon the decision of the Directorate.

ARTICLE 6 PARTICIPANTS OF THE CHAMPIONSHIP

6.1 CLUBS

- 6.1.1** The participants of the Championship may be Russian or foreign professional basketball clubs that are registered as legal entities under the laws of the country of their registration and undertake to fulfill the requirements and decisions of FIBA, the League, the Directorate, and these Regulations.
- 6.1.2** All Clubs participating in the Championship should be guided by the principles of bona fide business partnership, fairness, constant respect of opponents, Referees, and audience, and take all necessary measures to prevent violence and illegal actions at Sports Facilities.
- 6.1.3** Club Teams that are admitted for the participation in the Championship should meet the following criteria:
- availability of a Club Team that may participate in the Championship;
 - availability of a main Club Team, a Youth Team, and a CYBL Team/ Farm Team (for Russian Clubs only).



VTB UNITED LEAGUE REGULATIONS

SEASON 2020-2021

- availability of an own Sports Facility (or a lease or other contract for use of sport facility with its owner) with the capacity of no less than five thousand (5,000) seats (individual exclusions may be made for participants of VTB United League Championship of the 2019–2020 season upon decision of the Directorate approved by the Board of the League) to be the venue for home matches compliant with the provisions of these Regulations;
- the highest rank in the national championship (required only for Foreign Clubs, exceptions may be made by decision of the Board of the League);
- the presence of an international airport in the city where the sports facility where the Club's home matches will be held is located, which accepts regular and charter flights from European countries (the League Board may make individual exceptions for participants of the VTB United League Championship for the 2019–2020 season);
- a contract with a local TV company arranging video shooting of Home Games of this Club, production of TV signal and its transmission in accordance with requirements of the Regulations (for Foreign Clubs only);
- the presence of high-class hotels in the city where the sports facility where the Club's home matches will be held is located to accommodate opposing teams, sports Referees and League Officials, as well as VIP guests of the League;
- no bankruptcy or liquidation procedure initiated against the Club;
- no debts to FIBA, FIBA Europe, RBF, the League, as well as to the Players, Coaches, and other persons that have or used to have a labor contract with the Club and were included into the Team Passport in the previous seasons;
- sufficient financial resources to cover the budget of the Club's participation in the Championship;
- availability of a relevant consent issued by the national federation of the Club's country for the participation of the Club in the Championship (for Foreign Clubs only);
- fulfillment of all provisions of these Regulations.

6.1.4 The list of the participants of the Championship shall be approved by the Board of the League.

6.1.5 In order to become a participant of the Championship, a Club has to file a written participation request (in accordance with the form provided by the League) and enclose documents that confirm its correspondence to the criteria set in cl. 6.1.3 of these Regulations, including:

For Russian Clubs:

- Copies of title documents (Articles of Association, extract from the Unified State Register of Legal Entities, certificate of registration with tax authorities, certificate of registration in the Unified State Register of Legal Entities and assignment of a Primary State Registration Number (OGRN), a document confirming the appointment of a manager);
- Documents confirming the existence of a Sports Facility for hosting Home Games of the Club (a confirmation letter from the Club about hosting Home Games at the relevant Sports Facility with its detailed description; an extract from the Unified State Register of Real Estate about the owner of the Sports Facility; a letter from the owner of the Facility confirming its availability for hosting Home Games of the Club (in case the Facility is not owned by the Club); copy of a certificate issued by the Ministry of Sport of Russia confirming the registration of the relevant Facility in the All-Russia Register of Sports Facilities);
- A confirmation letter about the existence of a main Club Team, a Youth Team, and a CYBL Team/ Farm Team;



VTB UNITED LEAGUE REGULATIONS

SEASON 2020-2021

- A confirmation letter about the absence of debts to FIBA, FIBA Europe, RBF, the League, as well as to the Players, Coaches, and other persons that have or used to have a labor contract with the Club and were included into the Team Passport in the previous seasons;
- A confirmation letter about the absence of bankruptcy or liquidation procedures initiated against the Club;
- Financial documentation (financial reports for the previous reporting year drawn up in accordance with the legislation on accounting and reporting; a preliminary budget of the Club for the 2019–2020 season (according to a form provided by the League); a confirmation letter of good financial standing of the Club containing a brief description of the Club’s legal structure, ownership scheme, financial standing, main sources of funding, issues and their solutions; copies of contracts (sponsor, donation, subsidizing contracts or contracts on shareholder/ member capital contributions) for the season in which the Club wants to participate. In case no contracts have been concluded, confirmation letters from sponsors/members/other bodies and authorities that intend to conclude them are required).

For Foreign Clubs:

- Copies of title documents (Articles of Association, extract from a unified register of legal entities/ trade register, a document confirming the appointment of a manager);
- Documents confirming the existence of a Sports Facility for hosting Home Games of the Club (a confirmation letter from the Club about hosting Home Games at the relevant Sports Facility with its detailed description; an extract from a register of real estate about the owner of the Sports Facility; a letter from the owner of the Facility confirming its availability for hosting Home Games of the Club (in case the Facility is not owned by the Club));
- A confirmation letter about the absence of debts to FIBA, FIBA Europe, the League, as well as to the Players, Coaches, and other persons that have or used to have a labor contract with the Club and were included into the Team Passport in the previous seasons;
- A confirmation letter about the absence of bankruptcy or liquidation procedures initiated against the Club;
- Financial documentation (financial reports for the previous year; a preliminary budget of the Club for the 2019–2020 season (according to a form provided by the League); a confirmation letter of good financial standing of the Club containing a brief description of the Club’s legal structure, ownership scheme, financial standing, main sources of funding, issues and their solutions; copies of contracts (sponsor, donation, subsidizing contracts or contracts on shareholder/ member capital contributions) for the season in which the Club wants to participate. In case no contracts have been concluded, confirmation letters from sponsors/members/other bodies and authorities that intend to conclude them are required);
- A letter of consent for the participation of the Club in the Championship issued by the national federation.

All documents should be duly drawn up, i.e. sealed and signed by the Club. Copies of the documents shall be certified by the Club (with a seal and a signature of its manager).

The League guarantees confidentiality of the documents received from the Clubs. However, Russian Clubs authorize the League to disclose their budgets for the 2020-2021 season (drawn up in accordance with the form provided by the League) in mass media.

6.1.5.1 Entry for participation in the VTB United League Championship 2021–2022

Clubs – participants of the VTB United League Championship 2020–2021, are required before May 31, 2021 to submit their entry to the League in written form for participation in the VTB United League Championship 2020–2021 (using the form provided by the League), letter of intent (using



VTB UNITED LEAGUE REGULATIONS

SEASON 2020-2021

the form provided by the League), and attach documents stated in the item 6.1.5 of these Regulations confirming that criteria stated in the item 6.1.3 have been met by the Club.

Clubs that did not take part in the VTB United League Championship 2019–2020 are required before May 31, 2021 to submit their entry to the League in written form for participation in the VTB United League Championship 2021–2022 (using the form provided by the League), letter of intent (using the form provided by the League), and attach documents stated in the item 6.1.5 of these Regulations confirming that criteria stated in the item 6.1.3 have been met by the Club:

- availability of an own Sport Facility (or a lease or other contract for use of a sport facility with its owner) with the capacity of no less than five thousand (5,000) seats (individual exclusions may be made upon decision of the Board of the League) to be the venue for home matches compliant with the provisions of these Regulations;
- availability of an international airport receiving regular and charter flights from Russia and European countries on condition of no more than five (5) hours flights from Moscow in the city of a sport facility for staging Club home matches;
- availability of finances in the amount not less than planned budget of the Club for participation in the VTB United League Championship 2021–2022: not less than four hundred million (400,000,000) RUB for Russian Clubs; not less than five million (5,000,000) EUR for Foreign Clubs.

6.1.6 In case any Team refuses/is unable to participate in the Championship, the list of participants may be amended upon decision of the Board of the League.

6.1.7 Russian Clubs should have one main Team for the participation in the Championship, a Youth Team for participation in the Youth Championship, and a CYBL Team and/or Farm Team for the participation in the CYBL Competition and/or Russian National Basketball Championship among Superleague men's clubs (I or II divisions)—organized by RBF.

Additionally, a Russian Club should secure the participation of one of the teams listed above (except for the CYBL Team) in the Russian National Cup organized by RBF.

In case of non-fulfillment of this provision, a Russian Club is not admitted for participation in the Championship.

6.1.8 The name of the main Team of a Russian Club should be copied or be included into the names of all other Club Teams (Youth Team, Farm Team, and CYBL Team).

6.1.9 A Club or a Team may change its name during the season in exceptional cases and upon consent of the Directorate. A Club should inform the Directorate about changing its name in writing no later than six (6) calendar days before the next scheduled Game with the participation of the Club.

6.1.10 A Club or a Team may be excluded from participation in the Championship during a season by decision of the Directorate for grave violations of these Regulations, namely:

- for non-compliance with licensing requirements specified herein;
- for any violation of these Regulations that inflicts material financial damage to the League and/or adversely affects the hosting of the Championship, including abstaining from a Game (see art. 70 of these Regulations) excluding cases provided for in the p. 70.2. of these Regulations).

6.1.11 A Club is excluded from participation in the Championship in case:

- it refuses from participation in the Championship in accordance with art. 71 of the Regulations.

6.1.12 A Russian Club is automatically excluded from participation in the Championship in case:

- its Youth Team refuses from participation in the Youth Championship;



VTB UNITED LEAGUE REGULATIONS

SEASON 2020-2021

- its Farm Team and/or CYBL Team refuses from participation in the Russian National Basketball Championship – organized by RBF – among Super League men’s clubs/teams (I or II divisions) or the CYBL Competition;
- its Main Team, Youth Team, or Farm Team refuses from participation in the Russian National Cup.

In this case, a fine in the amount of two million five hundred thousand (2,500,000) RUB is imposed on the Russian Club.

6.1.13 In case a Club refuses or is excluded from participation in the Championship (cl. 6.1.10–6.1.12. of art. 6 of these Regulations) the place of the Club for the current season cannot be taken by another Club/Team.

6.1.14 The results of a Club excluded from the Championship are annulled. In the final classification this Club is given the last place.

6.1.15 Replacement of a legal entity entering Club/Team for participation in the Championship during sport season may be fulfilled in exceptional cases only by decision of the League on the following conditions:

- A new legal entity shall take responsibility of the legal entity that entered Club/Team for participation in the Championship to the full extent, including paying debts to FIBA, RBF, League and Players, Coaches or other persons on the team passport of the current or previous seasons by conclusion and submission of a relevant Agreement to the League;
- Labor contracts with Players shall be concluded by a new legal entity on the same or better conditions, i.e. the amount of salary, length of holiday, and submitted to the League and RBF;
- Other conditions stated by the League.

6.2 TEAM

6.2.1 A Club registers no more than twelve (12) and no less than ten (10) Players included into the Team Passport for each Game by means of filling a Technical Entry form. The form of the Game Technical Entry is specified in Annex No. 1 to these Regulations.

A fine in the amount of one hundred thousand (100,000) RUB is imposed on the Club for each missing Player out of ten (10).

Note: No penalty shall be imposed on the Club in case of shortage of players as a result of a positive test for COVID-19 and/or the quarantine measures introduced in respect of players, related to COVID-19 (subject to the Club's provision of documents confirming such information).

6.2.2 For Russian Clubs, in the Technical Entry for the Match shall be included and be on the bench at least six (6) Players with a N and/or Nn license category, of which no more than one (1) Player with Nn license category.

Note: No penalty shall be imposed on the Club in case of shortage of players as a result of a positive test for COVID-19 and/or the quarantine measures introduced in respect of players, related to COVID-19 (subject to the Club's provision of documents confirming such information).

6.2.3 A Technical Entry for a Game may not include more than twenty-one (21) people: twelve (12) Players, two (2) Coaches, and seven (7) Team Followers among the specified in the Team Passport. Only these people are allowed to stay at or around the Team bench during the Game and thirty (30) minutes before. Persons included in the Team Passport and performing special functions in the team, namely doctors and massage therapists, but not included in the Technical Entry for the Match, may be on the team bench or in the area of the team bench before the start of the presentation of teams in accordance with paragraph 33.1.5 of the Regulations. During the presentation of teams



VTB UNITED LEAGUE REGULATIONS

SEASON 2020-2021

(without the right to enter the playing area), the persons specified in paragraph 6.2.4 of article 6 of these Regulations may also be present in the team bench area.

For the violation of the rule on staying at or around the bench the Club is subject to a fine in the amount of one hundred thousand (100,000) RUB per each violator.

- 6.2.4** Club officials that occupy the following managerial positions cannot be included into a Technical Entry for a Game: President, Vice President, General Director, General Manager, CEO, Director, Deputy General Director and other Official club representatives.
- 6.2.5** A Technical Entry shall include a Team Representative at the Game from the list of Team Followers, specified in the Team Passport except for the persons listed in cl. 6.2.4 of art. 6 of these Regulations.
For violation, a fine in the amount of one hundred thousand (100,000) RUB is imposed on the Club.
- 6.2.6** A disqualified Player and/or another disqualified person that does not participate in a Game cannot be included into the Technical Entry for such a Game and is not allowed to stay around the Team bench.
- 6.2.7** In order to register Players, Coaches, and Team Followers for a Game, the Team Passport, licenses for Players, Coaches, and Team Followers and/or civilian passport identifying the Players, Coaches or Team Followers must be presented to the Game Commissioner.
- 6.2.8** The Club is liable for the authenticity of the data included in the Technical Entry.
In case of provision of inaccurate information, the sanctions are imposed on the Club that are determined by the Directorate.

6.3 PLAYERS

- 6.3.1** The Players participating in the Championship should be no less than fifteen (15) years of age as of the day of Club Licensing (i.e. the day of filing documents for Club Licensing or additional requests).
- 6.3.2** No more than twenty (20) Players in total and no more than sixteen (16) Players at the same time may be registered in the Main Team of the Club during the season.
- 6.3.3** A Player's License Category (N, Nn, F, U or F/E) is determined at the moment of licensing and cannot be changed during the current season, except for cases specified in cl. 6.3.3.1, 6.3.3.2, 6.3.3.3 of art. 6 of these Regulations.
- 6.3.3.1** For Russian Clubs, the "F/E" license of a Player may be changed to the "F" license in the event of an injury to a Player with an "F" license, provided that the following requirements are met at the same time:
- A Russian Club shall exclude an injured Player with an "F" license from the Team Passport before changing the "F/E" license to an "F" license;
 - a Russian Club may change the "F/E" license of a Player to "F" license no more than once during the sports season during the period from the first game of such a Russian Club in the Championship and no later than March 12, 2021 (the deadline for additional registration);
 - changing the "F/E" license of a player to "F" license will be considered a new Player's additional registration and will be included in the limit of twenty (20) players allowed per season (clause 6.3.2. of article 6 of the Regulations).
- 6.3.3.2** The Russian Club has the right to additionally register in place of a Player with an "F/E" license, whose license has been changed in accordance with the procedure established in paragraph 6.3.3.1. of article 6 of the Regulations, with an "F" license, a new Player ("F/E" license), provided that the requirements of these Regulations are met. For such a new Player, the provisions of paragraph



VTB UNITED LEAGUE REGULATIONS

SEASON 2020-2021

6.3.3.1. of article 6 of the Rules do not apply – his/her license of category "F/E" cannot be changed to a license of category "F".

6.3.3.3 For Russian Clubs, a Player's License that has been changed from category "F/E" to category "F" in accordance with clause 6.3.3.1 of article 6 of the Regulations, may be changed back from category "F" to category "F/E" provided that the following requirements are met simultaneously:

- return by the Russian Club of an injured Player to the Team Passport with a category "F" license who was previously excluded from the Team Passport in accordance with clause 6.3.3.1 of article 6 of the Regulations;
- a Russian Club may make such a change of a license category no more than once during the sports season in the period from the first game of such a Russian Club in the Championship and no later than March 12, 2021 (the deadline for additional registration);
- A player who has been registered by a Russian Club in accordance with clause 6.3.3.2 of article 6 of the Regulations shall be excluded from the Team Passport.

6.3.4 In case a Player becomes a Russian citizen being less than 16 years of age and is authorized to play for Russian national team, he or she is granted an N Category License.

6.3.5 For Russian Clubs during the season, no more than eight (8) Players with an "F" license and no more than one (1) Player with an "F/E" license can be entered in the Team Passport at the same time.

Note: These Regulations do not impose restrictions on the inclusion of players with a "U" License in the Team Passport of a Russian club participating in the Championship, provided that the requirements for the technical application of the Russian Club set out in clause 6.2.2. of article 6 of these Regulations are met.

6.3.6 A Team's Technical Entry should include no less than six (6) players that are citizens of the Club's country and are allowed to play for this country's national team in accordance with FIBA regulations (N Category Licenses). These Players should be at the Team bench.

For violation, a fine in the amount of three hundred thousand (300,000) RUB is imposed on the Club.

Note: No penalty shall be imposed on the Club in case of shortage of players as a result of a positive test for COVID-19 and/or the quarantine measures introduced in respect of players, related to COVID-19 (subject to the Club's provision of documents confirming such information).

6.3.7 During a season a Player may play alternately in no more than two Clubs that participate in the Championship.

If a Player has left the first Club in the current season, the second Club may apply for any category of Player's license in accordance with the provisions of these Regulations.

If a Player has left the first Club in the current season and played for the second Club, such a Player can be re-claimed for the first Club, while this Player is issued a license of the same category that was assigned to him/her at the time of licensing this Player for the first Club. This provision applies only to Players who transfer from Club to Club on a temporary transfer (lease) basis.

6.3.8 In the event of a claim for insurance compensation and/or a Player's absence due to an injury, Clubs are required to report all Player injuries and their causes to the League, as well as provide documentary evidence of the number of days missed due to this injury. The Club has the right to exclude an injured player from the Team Passport.

6.3.9 A Player removed earlier from a Team Passport due to injury or loan may be included into the Team Passport once again. The limit of twenty (20) allowed Players per season does not apply to such additional registration.



VTB UNITED LEAGUE REGULATIONS

SEASON 2020-2021

Note: The Player with category "F" license, previously excluded from the Team Passport because of an injury in the order of subclause 6.3.3.1 of these Regulations, may again be entered in the Team Passport instead of any Player with an "F" license subject to the limit of players with an "F" license established by subclause 6.3.5. of these Regulations. At the same time, the Russian Club has the right not to exclude from the Team Passport a Player with a category "F/E" license, registered in accordance with subclause 6.3.3.2 of the Regulations, and not to change the license to a Player whose license was changed from category "F/E" to category "F" in accordance with subclause 6.3.3.1. of these Regulations.

- 6.3.10** A Player that is not included into a Team Passport is not allowed to participate in the Championship (except for the rule set in cl. 6.4 of these Regulations for Russian Clubs).
- 6.3.11** Only the Players authorized to participate in national championships are admitted for participation in the Championship.

6.4 EXCHANGE OF PLAYERS WITH CLUB TEAMS (FOR RUSSIAN CLUBS)

- 6.4.1** Russian Clubs may register for the Games of the Championship no more than six (6) Players from their Youth Teams, Farm Teams and/or CYBL Teams provided there are registered labor contracts in the RBF.
- 6.4.2** To register Players from Youth Teams, Farm Teams and/or CYBL Teams for a Game, a Russian Club should produce to the Game Commissioner Team Passports of the Youth Team, Farm Team and/or CYBL Team, as well as Players' Licenses/Passports and/or documents proving the Players' identity (civilian passport).

6.5 COACHES, COACH ASSISTANTS, AND THE CLUB'S TEAM FOLLOWERS

- 6.5.1** During a season, a Coach may be registered for only one Team participating in the Championship at a time.
- Coaches and other Team Followers of a Russian Club included into a Team Passport of the Main Team, Youth Team, Farm Team and/or CYBL Team may be included into requests for the participation in the Games of the Championship without limitations (for Russian Clubs only).



VTB UNITED LEAGUE REGULATIONS

SEASON 2020-2021

CHAPTER 2

CLUB LICENSING AND ITS PROCEDURE

ARTICLE 7 GENERAL TERMS

7.1 Clubs are allowed to participate in the Championship provided they meet the requirements of these Regulations and upon decision of the Board of the League.

ARTICLE 8 DOCUMENTS PROVIDED BY CLUBS FOR LICENSING PURPOSES

8.1 Licensing is conducted as from date of approval of participants of the Championship by the Board of the League and shall be completed not later than seven (7) calendar days before the first Game of the Regular Championship.

8.2 In the course of the licensing procedure for the participation in the Championship a Club should file with the League the following documents:

8.2.1 **Not later than August 31, 2020**

- a contract between the Club and the League drawn up in two (2) copies in accordance with a form set by the League, signed by the Club;
- a contract of the national basketball federation of the Club's country with the League drawn up in two (2) copies in accordance with a form set by the League signed by the national federation (only for Foreign Clubs);
- a document confirming the ownership of the Club in respect of the sports facility where the Club's home matches will be played, or a lease agreement or other agreement for the provision of a sports facility. The contract shall ensure that the Club's home matches are played on the dates corresponding to the Schedule of games in the Regular Season, and on the dates (date intervals) of matches at all stages of the Play-offs according to the Schedule Plan;
- Club's questionnaire (the form of the Questionnaire is specified in Annex No. 2 to these Regulations);
- Conformity certificate of sport facility (Annex No. 3 to these Regulations)
- Financial documentation (a budget of the Club for the 2020–2021 season (according to a form provided by the League); copies of contracts (sponsor, donation, subsidizing contracts or contracts on shareholder/member capital contributions) for the season in which the Club wants to participate; confirmation letters from sponsors/members/other bodies and authorities that intend to conclude such contracts are required;
- List of Club sponsors, partners, advertisers for 2019–2020 specifying type of their activity, commodity categories and list of advertising services provided to the Club;
- Colorful templates of playing and training uniform in the pdf format in accordance with the form stated by the League according to Annex No. 4 to these Regulations for approval by the League;
- Club's logo (emblem, trademark, symbols) in pdf, jpg, cdr, eps formats and a document confirming the Club's title to the logo (emblem, trademark, symbols) (certificate, contract for use, etc.) and guidelines on use of logo (emblem, trademark, symbols);
- A brief description of the Club's history and activities (for Clubs that did not participate in the Championship of previous seasons).



VTB UNITED LEAGUE REGULATIONS

SEASON 2020-2021

8.2.2

Not later than September 13, 2020:

- the Club's application form in two (2) copies containing information about the Players, signed by the head of the Club, the Club's doctor and a sports medicine doctor with a transcript of the last name, first name, patronymic (if available), and certified with the seal of the Club and the seal of a medical organization licensed to carry out medical activities involving work (services) in physical therapy and sports medicine, confirming the absence of medical contraindications and admission to participate in Championship matches (Annex 5 to the Regulations);
- Club's Technical Entry in a set form in two (2) copies for Coaches, Officials and Team Followers, certified by Director General (Annex No. 5 to these Regulations);
- Application submitted by Players, Coaches, Officials and Team Followers to be granted access to participation in the Championship according to a form stated by the League;
- Declaration on non-participation in gambling by Players, Coaches, Officials and Team Followers according to a form stated by the League;
- Consent for processing of personal data from Players, Coaches, Officials and Team Followers;
- a copy of the insurance contract for Players, Coaches, Officials and Team Followers against accidents certified by the head of the Club;
- a certified copy of a voluntary medical insurance contract or a contract with a medical institution where Players, Coaches, Officials and Team Followers can receive additional medical services free of charge in excess of the mandatory medical insurance programs;
- Plan of the Club's/Team's measures to provide security and public order during Games of the Championship and an Instruction for securing public order and safety at the Sports Facility in two copies (see clause 39 of these Regulations) certified by an authorized organization;
- Copy of an official document (License, Passport, etc.) on the basis of which the Club participates in its national championship (for Foreign Clubs only);
- Contract with TV partner who will do video shooting of Club's home matches, production of TV signal and its transmission in accordance with requirements of these Regulations (for Foreign Clubs only);
- One (1) portrait photo of each team player included in the Technical Entry in jpg format (600x800 pixels, 300 dpi). Players in the photos should be in Team uniform approved by the League.

8.2.3

The list of additional documents to be presented by Russian Clubs for licensing purposes is specified in Annex No. 6 to these Regulations.

8.3

A Club should register at least ten (10) Players and one (1) Coach by September 13, 2020 and not less than thirteen (13) Players and other/remaining Team members not later than ten (10) calendar days before the first Game of the Regular Championship. First and last name of each Team member specified in the documents should be the same as announced in public statements and written on the Team uniform. Documents should be personally signed by each Team member.

8.4

Registration, additional registration, and de-registering of Coaches and official Team Followers may be carried out any time during a season provided such changes are confirmed by a copy of an official document issued for the national championship, and in case of Russian Clubs – after the filing of the documents listed in Annex No. 6 to these Regulations.



VTB UNITED LEAGUE REGULATIONS

SEASON 2020-2021

- 8.5** In case of non-compliance with the requirements specified in Article 8 of these Regulations, no official documents for the participation in the Championship are issued to a Club, and the Club is not admitted for participation.
- 8.6** In case of any changes in the Club's information (contact phone number, official representative, Coach's status, removal of a Player from the Team) the Club should inform the League about it in writing within three business days.
- 8.7** Clubs are liable for the authenticity of the data provided in the course of the licensing procedure in accordance with art. 8. In case of provision of inaccurate information, sanctions imposed on the Club are determined by the Directorate.

ARTICLE 9 DOCUMENTS ISSUED TO CLUBS AS A RESULT OF LICENSING

- 9.1** After licensing in accordance with Article 8 of these Regulations a Club admitted for participation in the Championship receives the following documents:
- Team Passport that is the main document confirming the Club's admittance to participation in the Championship;
 - Licenses of Players, Coaches, Official Persons and Team Followers;
 - a signed contract between the Club and the League;
 - a request for participation in the Championship approved by the League (if required by the Club);
 - the Regulations of the Championship;
 - Games Schedule.

ARTICLE 10 ADDITIONAL REGISTRATION OF PLAYERS

After receiving a Team Passport, a Club may additionally register Players in accordance with art. 10 of these Regulations.

10.1 The procedure of additional registration of Players for Foreign Clubs:

- in accordance with regulatory documents of national championships.

The procedure of additional registration of Players for Russian Clubs:

- the Players that did not play for Russian teams in the current season may be additionally registered by March 12, 2021;
- the Players that played for Russian teams in the current season may be additionally registered from December 1, 2020 till March 12, 2021 (inclusive).

The only exclusion is the Players of Russian Clubs that return to their Clubs from a loan. Such Players may be included into the Team Passport of their main Club regardless of the terms of additional registration.

10.1.1 During a season a Player of respective age may change Teams within a Russian Club (Main Team, Youth Team, Farm Team and/or CYBL Team) only once. A transfer shall be carried out in accordance with the provisions of the Regulations.

10.1.2 A Player of a Russian Club is prohibited to play for a Foreign Club in any competitions under the aegis of FIBA, FIBA Europe, and ULEB after he or she is registered for participation in the Championship except for All Stars Games and games played for national teams. In case the provision above is violated, a Player is disqualified from the Championship for a period of time determined by the Directorate.



VTB UNITED LEAGUE REGULATIONS

SEASON 2020-2021

- 10.1.3** In case a Player of a Russian Club leaves the first Club in the current season and plays for the second Club, such a Player may be registered for the first Club again regardless of the terms of additional registration. This provision only applies to Players that change Clubs in the course of the loan procedure. Loan decisions are made in accordance with a Player's RBF status. Repeated transfers of a Player between two Clubs in the framework of a loan procedure are not allowed.
- 10.2** Requests for additional registration should be filed with the League no later than twenty-four (24) hours before the beginning of the next Game. It means that documents should be delivered to the office of the League within this period of time. After the League approves the additional registration, the updated composition of the team is published on the official website of the League as quickly as possible.
- 10.3** In case additional registration documents are filed in electronic form or via fax, original copies of such documents should be delivered to the office of the League within five (5) business days.
- 10.4** Documents on additional registration shall be received by the office of the League via mail, fax, or e-mail no later than midnight of March 12, 2021.
- 10.5** No additional registration of Players is allowed after March 12, 2021.
- 10.6** Final compositions of the Teams shall be published on the official website of the League on March 13, 2021 not later than 6.00 pm.



VTB UNITED LEAGUE REGULATIONS

SEASON 2020-2021

CHAPTER 3

SPORTS FACILITIES.

REQUIREMENTS FOR THE COURT AND TECHNICAL

EQUIPMENT

ARTICLE 11 GENERAL TERMS

11.1 Any Sports Facility hosting the Games of the Championship should comply with the requirements of FIBA Official Basketball Rules and FIBA Official Basketball Rules - Basketball Equipment, set for level 1 competitions (hereinafter – level 1 competitions), as well as the requirements of these Regulations. All expenditures in relation to lease and/or provision of sport facilities for home matches (including training and games) will be borne by the Host Club.

Sports Facilities should meet the requirements of Regulation of the Government of the Russian Federation No. 353 dated April 18, 2014 “On the Approval of Safety Rules in the Course of Hosting Official Sports Competitions” and be included into the All-Russia Register of Sports Facilities in accordance with Federal Law of the Russian Federation No. 329-FZ dated December 4, 2007 “On Physical Culture and Sports in the Russian Federation” (for Russian Clubs only).

Sports facilities shall meet the sanitary and epidemiological requirements established by the authorities when operating facilities in the field of sports. In sports facilities, a set of operational measures should be developed that should be taken in the event of changes in the sanitary and epidemiological situation in accordance with the orders of the authorities, including for the prevention of new coronavirus infection (COVID-19).

Regular hygiene measures, disinfection, general cleaning and other hygiene measures shall be organized in sports facilities (including the use of antiseptics, keeping distances between individuals, contactless temperature control in sports facilities, and the possibility of holding Matches without spectators, if such a requirement is imposed by the authorities and the League).

11.2 An application of Sports Facilities for hosting home matches of the Championship shall be submitted by the Club according to Certificate of conformity of sport facility and accompanying documents (see Annex No. 3 to these Regulations) submitted during the licensing process (Article 8.2.1 of art. 8 of the Regulations).

In the Certificate of compliance of the sports facility, the Club shall declare the sports facility where it will hold home Matches as the main sports facility (hereinafter referred to as the main sports facility). The main sports facility shall accommodate at least five thousand (5,000) spectators, unless otherwise provided by these Regulations, and meet the requirements of these Regulations. The number of main sports facilities that the Club declared shall be at least one (1). If a Club declares two (2) or more main sports facilities, a separate Certificate of compliance of the sports facility shall be provided for each such sports facility.

11.3 Certificate of conformity (Annex No. 3 to these Regulations) is a document containing information on sport facility (location, size and number of playing courts, capacity, lighting, equipment, number of dressing rooms, etc.).

Certificate of conformity of the sport facility shall be signed by following authorities:

- Club official representative;
- Owner (asset holder) of sport facility;
- An authorized official responsible for engineering systems and sport facility in general (director or Senior Engineer of sport facility);



VTB UNITED LEAGUE REGULATIONS

SEASON 2020-2021

Certificate of conformity of sport facility should reflect all discrepancies in the requirements of valid FIBA Official Rules "Basketball equipment" and these Regulations as well as information on whether these discrepancies could be rectified (and dates of rectification). Certificate of conformity shall be accompanied by such documents as Annexes, described in the Certificate of conformity, duly certified by the Club.

- 11.4** Club shall stage all home matches of the Championship in the main Sports Facility. Reserve sport facility can be used only for five (5) matches of the Regular Championship. It is not allowed to use reserve sport facility for Play-off matches. If the Club violates this rule, **Directorate is entitled to impose a fine in the amount of five hundred thousand (500,000) RUB.**
Note: In cases provided for by p. 30.5. of this Regulation, the host Club shall have the right to play the Match in other sports facility declared by the participating Clubs of the Championship (for example, the host Club shall have the right to hold the Match in the sports facility of the rival Club, hereby remaining responsible for organization of the Match in such sports facility and for all related expenses imposed on the host Club by this Regulation. Such a Match will be considered for the host Club as a home match).
- 11.5** In exceptional cases when a match of a Regular Championship cannot be held at the main Sports Facility, including in cases where authorities or other organizations prohibit holding matches with spectators and/or it is recommended to hold matches with a limited number of spectators, the Host Club should send an official notification and a request for hosting the Game at the reserve site (specifying the reasons) within fifteen (15) calendar days at the latest. The Host Club is authorized to host a Home Game at its reserve site only after receiving a relevant permit from the Directorate. In case of untimely notification of the Directorate and sending a request (except of force majeure circumstances), **a fine in the amount of five hundred thousand (500,000) RUB** is charged from the Club.
In case a Game is held at a reserve site without the respective Directorate's permit, **a fine in the amount of one million (1,000,000) RUB is charged from the Club.**
- 11.6** It is prohibited to stage Championship games at Sports Facilities not declared by the Club according to Article 11.2 of art. 11 of these Regulations.
In case of violation of the above provision, the Host Club loses the game "FORFEIT", and a fine in the amount of two million (2,000,000) RUB is charged from the Club.
- 11.7** The League is entitled to inspect sport facility in order to check relevance of data of the Act of conformity of a sport facility at any time during sport season having informed the Club at least five (5) days in advance to the suggested date of inspection. Expenditures related to business trip of the League experts authorized by the Leagues to inspect sport facility shall be borne by the League.
- 11.8** The Club shall provide access to the League employees inspecting sport facility and assist in fulfillment of their inspection duties.
- 11.9** During the inspection of the sports facility, the premises shall be in a condition corresponding to the state of readiness for the Championship Matches.
- 11.10** The Club should prepare rooms for measurements and inspections in accordance with the requirements of the employees of the League. The Club shall secure the presence of a person in charge of operation of engineering system and the Sports Facility in general (Chief Engineer of the Sports Facility) or his/her deputy during the whole period of inspection.
- 11.11** In the course of inspection of Sports Facility, the Club shall submit to the League the documents specified as appendices to the certificate of compliance of the sports facility (Annex 3 to this Regulation). In addition, the sports facility shall ensure the availability and placement in easily accessible places:



VTB UNITED LEAGUE REGULATIONS

SEASON 2020-2021

- schemes of the audience's movement around the Facility, access to the seats and evacuation routes, location of fire-fighting equipment;
- rules of conduct of the visitors;
- other documents provided for by the legislation of the country in the territory of which a Sports Facility is located, and regulating the activities of said Sports Facility (technical operation, safety measures, medical services, etc.) (for Foreign Clubs only).

11.12 In case of non-compliance of sport equipment or sport facility declared in the Certificate of conformity of sport facility is discovered during an inspection visit, the Directorate may decide to rectify violation, to ban hosting matches/training in this sport facility and/or impose a fine in the amount of **up to one million (1,000,000) RUB**.

When revealed violations have been rectified, the Club shall send to the League an official notification describing in detail the works done and current parameters. The League has the right to inspect sport facility according to provisions of these Regulations. The Club will pay a fee in the amount of **one hundred thousand (100,000) RUB** to the League account number for the second inspection of sport facility.

11.13 On the basis of the Certificate of compliance of the sports facility submitted by the Club, as well as the results of inspection in cases stipulated by the Regulations, the Directorate makes a decision on the possibility/impossibility of holding Championship Matches in this sports facility.

ARTICLE 12 PLAYING COURT

12.1 Matches of the Championship are held at the courts that comply with the requirements of FIBA Official Basketball Rules and Basketball Equipment Annex to them.

12.2 The size of the playing court should be as follows: length – twenty-eight (28) meters, width – fifteen (15) meters (see Art. 2, cl. 2.1. of FIBA Official Basketball Rules).

12.3 Any obstacles including a Team's substitutes bench should be located no less than two (2) meters from the court (see Art. 2 of cl. 2.4.1. of FIBA Official Basketball Rules). The exceptions from this provision are specified in Art. 14 of these Regulations.

12.4 The surface of the court should be permanent (static) or movable (demountable) wood covering. Static and/or movable wooden covering should correspond to functional sport requirements specified in art. 10 of the FIBA Official Basketball Rules – Basketball Equipment for level 1 competitions.

12.4.1 A court should be marked with white lines five (5) centimeters wide or other contrasting color as well as with an additional marking line of a contrasting color that is no less than two (2) meters wide (cl. 11.1. of art. 1 of the FIBA Official Basketball Rules – Basketball Equipment).

12.4.2 A court should be marked with additional boundary line of a contrasting color that is no less than two (2) meters wide (cl. 11.1. of art. 1 of the FIBA Official Basketball Rules – Basketball Equipment). In case of violations the Club will pay a fine in the amount of one hundred thousand (100,000) RUB.

12.5 Playing court should be evenly and sufficiently lighted in accordance with Annex 7 of these Regulations.

12.5.1 When measured horizontally at one (1) meter height from surface, lighting of the playing court should be 2,000 to 2,500 LUX and it should be **even**. When measured vertically against the position of the main camera the average lighting of the court should be no less than 1,250 LUX.

12.5.2 It is recommended to provide gradual reduction of lighting in sport facility according to Annex No. 7 to these Regulations by 50% in rows from 1 to 7 and further gradually to 5% in the last row.



VTB UNITED LEAGUE REGULATIONS

SEASON 2020-2021

- 12.5.3** Playing court should be completely lightened sixty (60) minutes before the beginning of each Game. The lighting may be temporarily switched off for the purpose of a pre-Game ceremony or show.
- 12.5.4** Playing court should be completely lighted for thirty (30) minutes after the end of each Game to secure the work of television and press.
- 12.5.5** A Host Club should secure complete lighting of the playing court in accordance with Annex No. 7 to these Regulations during pre-game training of a Guest Club.
- 12.5.6** Sport facility should have an autonomous lighting system.
For violation of cl. 12.5.1–12.5.6 of art. 12 of the Regulations at the Games of the Championship, a fine in the amount of two hundred thousand (200,000) RUB is imposed on the Club for each violated clause.
- 12.6** The height of the ceiling or the distance between the ceiling and the lowest item of the court should be no less than seven (7) meters (see cl. 11.4. of art. 11 of the FIBA Official Basketball Rules – Basketball Equipment).
- 12.7** Sport facility should be equipped with a thermometer for measuring air temperature at playing court, a manometer for measuring air pressure inside the ball, a device for measuring level of sound pressure (noise), and a lux meter to measure level of lighting.
For the violations at Championship Games, a fine in the amount of one hundred thousand (100,000) RUB is imposed on the Club.
- 12.8** Air temperature at the playing court during a Game should not be below eighteen degrees (18 C) and no more than twenty-five degrees (25 C).
For the violations at Championship Games, a fine in the amount of two hundred thousand (200,000) RUB is imposed on the Club. In case of difference of the set temperature limits by over three degrees (3 C), the Commissioner should immediately inform the Directorate. In this case the Directorate is entitled to impose additional sanctions on the Host Club up to its defeat "FORFEIT".

ARTICLE 13 BACKBOARD STANDS, BACKBOARDS, AND BASKETS

- 13.1** A sport facility should have backboard stands (hereinafter referred to as the stands). The stands should be fixed on the floor in such a way as to exclude any movement under the influence of the pressure during the game or the falling of the stands. The construction and location of the stands should correspond to the parameters set in the Basketball Equipment Annex to FIBA Official Basketball Rules.
- 13.2** Backboards should be made of a single piece of tempered unbreakable glass with safe structure (i.e. without the formation of sharp shards when destroyed) encased in a rigid metal frame. The size of a backboard should be 1,800 (+max 30 mm) x 1,050 mm (+max 20 mm) (see cl. 1.1 of art. 1 of the FIBA Official Basketball Rules – Basketball Equipment).
- 13.3** The front part of the construction to which a backboard is fixed should be located no less than two (2) meters from the outer edge of the front line of the Basketball Equipment Annex to FIBA Official Basketball Rules for level 1 competitions).
- 13.4** A backboard and a stand should be covered with lining (see cl. 1.5 of art. 1 of the FIBA Official Basketball Rules – Basketball Equipment).
- 13.5** Each backboard should have lanterns attached to its internal edges along the perimeter. The lanterns should light red after the game clock signals the end of the quarter.
Each backboard should have a lantern fixed in its upper part and lighting yellow after shot clock signal.



VTB UNITED LEAGUE REGULATIONS

SEASON 2020-2021

For the violation of cl. 13.1–13.5 of art. 13 of the Regulations at Regular Championship games a fine in the amount of two hundred thousand (200,000) RUB is imposed on the Club.

- 13.6** The rings should be made of hard steel and correspond to the requirements of cl. 1.2 of art. 1 of the FIBA Official Basketball Rules – Basketball Equipment and have an amortization device (see subcl. 1.2.7 of cl. 1.2 of art. 1 of the FIBA Official Basketball Rules – Basketball Equipment).
- 13.7** Nets should be made of white cord and correspond to the requirements of cl. 1.3 of art. 1 of the FIBA Official Basketball Rules – Basketball Equipment.
- 13.8** A sport facility should have at least one (1) supplementary stand and one (1) backboard as close to the playing court as possible that should be fully functional and ready for quick replacement of damaged equipment.
- In case of the absence of a supplementary backboard and/or a reserve stand when a replacement is required at Championship Games, a fine in the amount of five hundred thousand (500,000) RUB is imposed on the Host Club, and it loses "FORFEIT".**
- 13.9** A Host Club shall have all necessary tools and personnel for quick replacement of damaged equipment specified in Article 13 of the Regulations (within no more than 30 minutes).
- For violations at Championship Games, a fine in the amount of three hundred thousand (300,000) RUB is imposed on the Club.**

ARTICLE 14 SEATS FOR SPECTATORS

- 14.1** All rows and spectator seats shall comply with article 16 of the FIBA Official Basketball Rules – Basketball Equipment and shall be numbered.
- 14.2** The seats for spectators can be located along the side line opposite to the benches of the Players. Enough space should be left for the placement of TV cameras in the center of the court (1.5 meters to each side from the central line).
- Spectator seats along the sideline can be located directly at the level of the floor board, while the feet of those sitting in these seats cannot be located closer than 3 meters from the outer edge of the bounding lines of the playing court.
- 14.3** The seats for spectators near the front line should be placed in such a way as to leave a passage near the stand and a place for a cameraman. The passages on both sides of the ring stand should be no less than 0.8 meters wide and no less than 2 meters deep. The place for the cameraman should be no less than 0.5 meters wide and no less than 2 meters deep.
- The seats of the audience near the front line may be located directly on the level of the floor covering, but the feet of the audience sitting in their seats cannot be located less than three (3) meters from the outer edge of marking lines. Seats for spectators should be located behind advertising construction (LED) placed in accordance with Annex No. 8 to the Regulations.
- 14.4** At Championship Games, a sector used for support of the Host Club by their organized fans should not:
- be located behind the bench of the Guest Team;
 - be located at the distance closer than fifteen (15) meters from the bench of the Guest team.
- Location of a sector for active support of the Host Club in a sport facility and a number of seats in this sector shall be agreed upon by the Host Club with the League prior to the Championship.
- For violation, a fine in the amount of three hundred thousand (300,000) RUB is imposed on the Host Club.**
- 14.5** At Championship Games, seats provided by the Host Club to the Guest Club for the organization of its active support sector and seating of organized fans of the Guest Club (see Art. 35 of these



VTB UNITED LEAGUE REGULATIONS

SEASON 2020-2021

Regulations) should not be located closer than fifteen (15) meters from the active support sector of the Host Club.

Location of a sector for active support of the Host club in a sport facility and a number of seats in this sector shall be agreed upon by the Host Club with the League prior to the Championship.

For violation, a fine in the amount of three hundred thousand (300,000) RUB is imposed on the Host Club.

ARTICLE 15 BASKETBALLS

15.1 The basketballs should meet the requirements of cl. 2 of the FIBA Official Basketball Rules – Basketball Equipment for level 1 championships, in particular, their circumference should be no less than 750 mm and no more than 770 mm (size 7), and weight should be no less than 580 g and no more than 620 g (see cl. 2.4 of art. 2 of the FIBA Official Basketball Rules – Basketball Equipment).

15.2 Official balls shall be used for all games and training of the Championship.
The League should provide each Club participating in the Championship with official balls and baskets, twenty (20) balls and one (1) basket/stand per one (1) Club.
Clubs are not allowed to use basketballs and baskets/stands manufactured by companies other than manufacturer of an official ball.

In case of absence of official balls at Championship Games, a fine in the amount of five hundred thousand (500,000) RUB shall be imposed on the Host Club.

In case of absence of baskets/stands for official balls manufactured by a designated manufacturer of official ball, a fine in the amount of one hundred thousand (100,000) RUB shall be imposed on the Host Club.

ARTICLE 16 REFEREES' TABLE

16.1 Referees table should be no less than six (6) meters long and no less than eighty (80) centimeters high and at least ten (10) chairs for table secretaries and commissioner should be located at a sport facility on a risen platform no less than twenty (20) centimeters near the middle of the side line (cl. 16.2 of art. 16 of the FIBA Official Basketball Rules – Basketball Equipment). The referees' table shall be positioned so that its center on the long side coincides with the central line of the marking of the playing court.

ARTICLE 17 TEAM BENCHES

17.1 17.1 The zones of team benches should correspond to FIBA Official Basketball Rules (subcl. 2.4.5 of cl. 2.4 of art. 2 of the FIBA Official Basketball Rules).

17.2 An area for benches for teams should be marked on the same side of the court as the scorer's table. This area should be marked with a line that is at least two (2) meters long and is a continuation of the base line, and another two (2) meters long line placed five (5) meters away from the central line and at right angle to the side line. The lines marking the area should be the same as the court marking.



VTB UNITED LEAGUE REGULATIONS

SEASON 2020-2021

- 17.3 Benches or chairs with backrests for teams should be symmetrically placed within the marked area. The number of seats should be no less than sixteen (16) for each team.
- 17.4 Benches or chairs with backrests for teams should be at least five meters (5) from seats of spectators.

ARTICLE 18 VIDEO SCREENS AND VIDEO CUBES

- 18.1 Sport facility should be equipped with at least one (1) and preferably two (2) colorful video screens with high resolution clearly visible for all spectators, or video cubes.
- 18.2 Location of screens should not prevent spectators from watching the match. Video screens should show images without distortion of picture and color. Video screen should demonstrate full picture. Non-operating devices on video screen are not allowed.
For violation, a fine in the amount of two hundred thousand (200,000) RUB shall be imposed on the Host Club.
- 18.3 If the sport facility is equipped with a video cube, it shall have at least four video screens of high resolution located above the center of the playing court and clearly visible to all spectators.
- 18.4 Sport facility with the capacity of over five thousand (5,000) seats **shall** be equipped with a video cube consisting of at least four high-resolution screens. The re-equipment of sport facilities without media cubes should be finished before the beginning of the 2020–2021 season.
- 18.5 Video cube should show images without distortion of picture and color. Video cube shall demonstrate full picture. Non-operating devices on video screen are not allowed.
For violation, a fine in the amount of two hundred thousand (200,000) RUB shall be imposed on the Host Club.

ARTICLE 19 SCOREBOARD/VIDEO BOARD

- 19.1 A Sport facility should be equipped with two (2) big score/video boards that meet the requirements of Article 3 of the FIBA Official Basketball Rules – Basketball Equipment for level 1 competitions. One (1) score table should be placed at each face side of the court and be clearly visible to everyone involved in the game including the audience.
- 19.2 Score/video board should include and/or demonstrate.
- game clock with digital countdown in the format of minutes and seconds (mm:ss), as well as accurate to tenths (1/10) of a second only during the last minute of a quarter or overtime;
 - Points won by each team;
 - Overall number of points won by every particular player;
 - Number of every particular player (in the order 00, 0, 1, 2, 3, 4, 5, 6, 7, 8, 9, 10 and 11–99) and their respective surnames. There should be at least twelve (12) characters to reflect surname of each player;
 - Teams' names. There should be at least three (3) characters to reflect name of each team on the board;
 - Number of fouls performed by each player, from 1 to 5. This number can be demonstrated by five (5) indicators or figures at least 135 mm high. The fifth foul shall be in red or orange. In addition, the 5th foul can be shown as indicator with a slow flickering (- 1 Hz) during five (5) seconds;



VTB UNITED LEAGUE REGULATIONS

SEASON 2020-2021

- the number of team fouls from 1 to 4, as well as the square that should be marked in red after the 4th team foul and appear in place of the number 4 after the 4th team foul at the start of the game clock. The size of the red square shall be in the range from 80% to 120% of the width of the digit 4;
- Quarter number from 1 to 4 and “O” for overtime;
- Number of requested time-outs from 0 to 3. When the game clock shows two (2) minutes or less in the fourth quarter, a team can use no more than two (2) timeouts from the remaining unused ones. All other timeouts shall be displayed as used;
- Clock for count down of time-out.

If a score/video board does not correspond to the above requirements at Championship games, a fine in the amount of one hundred thousand (100,000) RUB will be imposed on the Club.

If a score/video board has a failure before the beginning of the Game or there is no board at Championship games, a fine in the amount of five hundred thousand (500,000) RUB will be imposed on the Club.

If a score/video board fails during Championship game, a fine in the amount of one hundred thousand (100,000) RUB will be imposed on the Club.

ARTICLE 20 GAME CLOCK

- 20.1** Game clock should be placed in a sport facility. Game clock should meet the requirements of Article 4 of the FIBA Official Basketball Rules – Basketball Equipment for level 1 competitions:
- Have a digital count down device with automatic signal producing sound after the end of a quarter or overtime as soon as display demonstrates nulls (00:00.0);
 - Have a capacity to show remaining time in minutes and seconds and with an accuracy to the tenth of a second (1/10) only during the last minute of a quarter or overtime;
 - Be placed in such a way so that be clearly visible to everyone who is engaged in the game including spectators.
- 20.2** Automatic signal of game clock confirming the end of playing time should be easily distinctive in adverse noisy conditions. Loudness of the sound measured at one-meter distance from the source of noise should correspond to **one hundred twenty (120) decibels**. Club shall submit the device for measurement of noise level (in decibels) on demand of the Match Commissioner.
A fine in the amount of one hundred thousand (100,000) will be imposed on the Club for violation.
- 20.3** In case the main game clock is placed over the center of the court, the backup clock should be displayed at synchronous electronic watch at both face sides of the court located high enough to be clearly visible to everyone involved in the game including the audience. Backup electronic clock should display the score and the remaining game time during the game.
- In case a game clock proves to be defective before the beginning of a Championship Match or there is no game clock, a fine in the amount of one hundred thousand (100,000) RUB will be imposed on the Club.**
- In case a game clock proves to be defective during a Championship Match, a fine in the amount of one hundred thousand (100,000) RUB will be imposed on the Club.**
- In case a game watch proves to be defective during a Play-Off Game and as a result game was stopped, a fine in the amount of three hundred thousand (300,000) RUB will be imposed on the Club.**



VTB UNITED LEAGUE REGULATIONS

SEASON 2020-2021

- 20.4** Each Host Club shall provide each Referee with automatic stop-time devices at the whistle, which shall be synchronized with the game clock and shall comply with article 13 of the FIBA Official Basketball Rules – Basketball Equipment. The readiness of the automatic stop time devices to work at the whistle is checked by the referees before the start of each Match no later than fifteen (15) minutes before the start of the Match.
- In case the device proves to be defective before the beginning of a Championship Match or there is no such device, a fine in the amount of two hundred thousand (200,000) RUB will be imposed on the Club.**
- In case the device proves to be defective during a Championship Match, a fine in the amount of one hundred and fifty thousand (150,000) RUB will be imposed on the Club.**
- 20.5** Every Host Club shall save data on the operation of automated stopping time device after a whistle after home match in the format reflecting time of stop/start of the game clock/ shot clock by every Referee and Scorer on a match. These saved data should be at the disposal of Host Club at least fourteen (14) days after the end of the Match. Data should be submitted to the League on their demand.
- A fine in the amount of two hundred thousand (200,000) RUB will be imposed on the Club for violation.**

ARTICLE 21 SHOT CLOCK

- 21.1** An automatic digital device for time keeping before a throw compliant with the provisions of cl. 5 of the FIBA Official Basketball Rules – Basketball Equipment for level 1 competitions shall be placed at sport facility. The device should count down time in seconds **with a very loud automatic signal different from the signal at the end of the game time** that is produced when display shows 0 (null).
- 21.2** The signal shall be easily distinguishable in adverse noise conditions. The sound volume, measured at a distance of one meter from the sound source, shall correspond to **one hundred and twenty (120) decibels**. At the request of the Game Commissioner, the Club shall provide a device for measuring the sound level (in decibels).
- 21.3** Shot clock should switch on from twenty-four (24) and from fourteen (14) seconds, to stop and show the remaining seconds on the display, to continue counting from the time of stop and, if necessary, show no indication (cl. 5 of the FIBA Official Basketball Rules – Basketball Equipment). Shot clock shall display tenths of a second (1/10) after the end of the fifth (5) second.
- 21.4** Timer's display together with the duplicate game clock should be attached to each base supporting the backboard, at least thirty (30) cm above the backboard and behind it or fixed to the ceiling.
- If a shot clock fails prior to the beginning of a Championship Match or if there is no timer available, a fine in the amount of two hundred twenty thousand (200,000) RUB will be imposed on the Club.**
- If a shot clock fails during a Championship Match, a fine in the amount of one hundred fifty thousand (150,000) RUB will be imposed on the Club.**
- 21.5** A display of a shot clock together with duplicating game clock shall have three (3) or four (4) surfaces for each device or two devices with two-sided surface.
- For violation, a fine in the amount of one hundred thousand (100,000) RUB will be imposed on the Club.**



VTB UNITED LEAGUE REGULATIONS

SEASON 2020-2021

ARTICLE 22 ADDITIONAL EQUIPMENT. FACILITIES IN A SPORT FACILITY

- 22.1** There shall be at least two autonomous, distinctly different, loud sound signals in a sport facility:
- one (1) is at the disposal of a timekeeper and a table official and shall sound automatically, indicating the end of the playing time of a quarter.
 - one (1) is at the disposal of a shot clock operator and shall sound automatically, indicating the end of the 24-second period. Both signals, easily distinguishable by sound, shall be powerful enough to be easily heard in the most adverse noise conditions. The sound volume shall adapt to the dimensions of a playing court and tribunes for spectators and the noise created by the spectators, to a maximum sound pressure level of one hundred and twenty (120) decibels, measured at a distance of one (1) meter from the sound source.
 - Timekeeper and secretary shall be able to give a sound signal in the manual mode (that is, a console with a signal button for a timekeeper, and also for a secretary shall be available), when it is necessary to attract the attention of the Referees.
- 22.1.1** Sound signals shall be switched on to sound-amplifying system of sport facility.
In the absence and/or malfunction of the sound signals during a Championship Match, a fine in the amount of one hundred thousand (100,000) RUB is imposed on the Club.
- 22.2** Sports facility shall be equipped with microphone for announcer/master of ceremony, sound-amplifying equipment and acoustic system.
For violation at Championship Match a fine in the amount of one hundred thousand (100,000) RUB is imposed on the Club.
- 22.3** Host Club shall have a reserve set of the following equipment:
- 22.3.1** Scoreboard including and/or demonstrating:
- Game clock with digital countdown and ability to produce sound signal;
 - Points won by each team;
 - Number of team fouls from 1 to 5 (with a possibility to stop at maximum of 5);
 - A separate control station for monitoring reserve scoreboard managed by Secretary Assistant (Scoreboard Operator);
 - Manufacturers should describe in details principles of interaction between reserve scoreboard, reserve shot clock and control stations in order to have the possibility to combine different devices.
- 22.3.2** Shot clock shall be equipped with:
- a separate control station with a very loud automatic signal at the end of 24-seconds period, when display shows null (0), provided to timer operator;
 - at least, two (probably portative) displays with digital countdown showing time in seconds.
- This reserve equipment can be used in exceptional cases if main equipment described in Articles 19 and 21 of the Regulations fails.
For violation, a fine in the amount of two hundred thousand (200,000) RUB will be imposed on the Club.
- 22.4** Internet access
Sport facility shall have Internet access:
- at least one (1) dedicated Internet line (wired connection) with guaranteed bandwidth of at least ten (10) Mbit/s at the Referees table for statistical purposes and textual on-line broadcasting of the game. Modem, mobile (3G/4G/LTE) and Wi-Fi for textual on-line



VTB UNITED LEAGUE REGULATIONS

SEASON 2020-2021

broadcasting are not allowed. It is recommended to possess dedicated reserve line with similar characteristics for textual online broadcasting of the game.

- at least one (1) dedicated line (wired connection) with guaranteed bandwidth of at least one hundred (100) Mbit/s at parking of PTS vans for producing TV signal of the Match and its transmission.
- Wi-Fi connection of at least five (5) Mbit/s for one (1) connection or cable connection at least five (5) Mbit/s for one (1) connection in the media working area next to playing court (press tribune), press-conferences room and press-center, shall be provided.

For violation at a Championship Match a fine in the amount of two hundred thousand (200,000) RUB is imposed on the Club.

22.5

Sport facility shall be equipped with an advertising construction along the perimeter of a playing court consisting of LED screens meeting requirements of Article 12 of these Regulations and Article 15 of the FIBA Official Basketball Rules – Basketball Equipment.

Every component of LED screen shall meet requirements of safety, bring no discomfort to participants of the Match when they enter playing court and exclude risk of injuries for participants of the Match. LED screens should have:

- Screens without sticking out elements;
- Padding on the top and sides;
- Fixed protective back panel.

LED screens shall display images without distorting the content. Images shall be shown on LED screens in full. Non-operating elements on LED screens are not allowed.

A fine in the amount of two hundred thousand (200,000) RUB will be imposed on the Host Club for violation.

22.6

Premises in a sport facility

Sport facility shall have the following rooms that can be locked with a key:

- Equipped locker-rooms for teams;
- Equipped locker-rooms for Coaches;
- Equipped locker-room for Referees, Commissioner and Official Delegated Inspector;
- Equipped locker-room for a table officials crew;
- First-aid center for Players, spectators, other participants of the game (medical stations).
- Doping control room.
- VIP rooms.
- Press-conference room.
- Press-center (a working room for the press).
- Availability of sufficient number of seats for accredited reporters (tribunes for the press);

22.6.1

Each team's locker-room shall be equipped with at least the following:

- fifteen (15) individual lockers for individual storage of clothes, shoes and personal belongings. Each locker shall be comfortable and have enough space to change clothes, and also shall be equipped with coat hangers;
- two (2) massage tables;
- two (2) WCs with individual booths;
- four (4) shower cabins with hot water;
- two (2) mirrors, two sinks and two urinals;
- main game clock;
- a wipe dry board.



VTB UNITED LEAGUE REGULATIONS

SEASON 2020-2021

- 22.6.2** Each Coach's locker-room shall be equipped with at least the following:
- three (3) individual lockers for individual storage of clothes, shoes and personal belongings. Each locker shall be comfortable and have enough space for changing of clothes, and also equipped with shoulders;
 - one (1) WC room;
 - one (1) shower booth with hot water;
 - a mirror, a sink;
 - a desk.
- 22.6.3** A changing room for Referees, the Commissioner and the Official Delegated Inspector shall be equipped with at least the following:
- five (5) individual lockers for individual storage of clothes, shoes and personal belongings or a wardrobe for storing clothes, shoes and personal belongings and armchairs.
 - one (1) WC room;
 - one (1) shower booth with hot water;
 - a mirror, a sink;
- 22.6.4** Each locker-room for a table officials shall be equipped with at least the following:
- nine (9) individual lockers for individual storage of clothes, shoes and personal belongings or a wardrobe for storing clothes, shoes and personal belongings and armchairs.
 - a mirror.
- 22.6.5** Doping control room:
Doping control room shall be equipped according to the requirements stipulated in the FIBA Internal anti-doping Regulations.
Doping control room and first aid station should not be identical (these should be different rooms).

ARTICLE 23 TECHNICAL SUPPORT

- 23.1** The Host Club is responsible for the conformity of the sports facilities where games are held to the requirements of these Regulations (Chapter 3 of these Regulations), as well as for ensuring and having all the technical equipment in the sport facility in working condition and its compliance with the requirements of the FIBA Official Basketball Rules, FIBA Official Basketball Rules – Basketball Equipment, and these Regulations.
- 23.2.** The Host Club shall ensure availability in sports facilities of technical equipment specialists necessary for the Game, who are capable of eliminating malfunctions in its operation within the shortest possible time.
- 23.3.** If, due to non-functioning and/or missing equipment, the presence of which the Host Club shall provide under these Regulations, there was a delay and/or cancellation of a Championship Match which resulted in the delay and/or cancellation of the television broadcast, **a fine of five hundred thousand (500,000) RUB shall be imposed on the Club.**
In addition, by the decision of the Directorate, the Host Club may be entrusted with expenses incurred by the League in the organization of a television broadcast.



VTB UNITED LEAGUE REGULATIONS

SEASON 2020-2021

CHAPTER 4

OUTFIT OF GAME PARTICIPANTS

ARTICLE 24 GENERAL PROVISIONS

- 24.1** Players can take part in Games only in sports equipment (playing and warming-up uniform, socks, shoes), which meets the requirements of FIBA Official Basketball Rules and these Regulations.
- 24.2** Playing uniform for all team members consists of a vest, shorts, socks. All teams shall have two (2) sets of playing uniform. One set of light color, the other – dark. Both sets of playing uniform cannot have different semitones of the same color.
- Colors of playing team uniform should be distinctive at any Match. It is recommended that one team is in light uniform and the other team in dark, however, in any case, colors of a playing uniform should be clearly distinctive (contrast to each other), for example, one team plays in red, the other team in green.
- The logo (name) of the manufacturer, logo and name of the Club, size and type of lettering of numbers and names of players as well as advertising on playing and warm-up uniform (warm-up T-shirt with short/long sleeve and warm-up pants) should be the same for all Team players.
- 24.3.** Players of the Club have the responsibility to take part in the Championship Matches only in playing and warm-up uniform corresponding to models of playing and warm-up uniforms for this Club approved by the League.
- Commissioner in agreement with Directorate has the authority to ban players committed violation from the Match.**
- 24.4.** Club shall send models of playing and warm-up uniform for approval by the League before August 31, 2020. Club shall design models of playing and warm-up uniform based on requirements of the Regulations (Article 4 of these Regulations) according to a form approved by the League in compliance with Annex 4 to these Regulations and send in color in pdf format to the League.
- The League will ensure conformity of playing and warm-up uniform to requirements of the present Regulations. League reserves the right to refuse approval of the models of playing and warm-up uniform if names of sponsors (partners, advertisers) of the Club are displayed on the uniform, violating rights of the League in commodity categories, reserved by the League.
- If models of playing and warm-up uniform meet requirements of the Regulations and displayed names of sponsors (partners, advertisers) of the Club do not infringe rights of the League in commodity categories reserved by the League, they will send an information letter to the Club on approval of the model of playing and warm-up uniform.
- If models of playing and warm-up uniform do not meet requirements of the Regulations and/or if displayed names of sponsors (partners, advertisers) of the Club infringe the rights of the League in commodity categories reserved by the League, they will send an information letter to the Club highlighting required amendments to be made, and Club has to duly amend the models within 3 days and send them back to the League for repeated approval.
- A fine in the amount of one hundred thousand (100,000) RUB will be imposed on the Club for violation.**
- 24.5.** A Club shall ensure conformity of playing and warm-up uniform with models approved by the League and participation of players in the Championship Matches in playing and warm-up uniform corresponding to models approved by the league.



VTB UNITED LEAGUE REGULATIONS

SEASON 2020-2021

No changes are allowed during the season to playing and warm-up uniform of the Club without approval by the League.

During the season, changes may be made to the playing and warm-up uniform solely due to a change of equipment manufacturer, color, change/addition of a sponsor (partner, advertiser) of the Club, or due to the Club conducting one-time marketing, social and other actions (for example, holding a Match on public holidays, anniversary events of the Club).

The Club shall send the modified playing and/or warm-up uniform layouts to the League for approval by the League no later than seven (7) calendar days before the date of the Match in which the Club plans to participate in the modified playing and/or warm-up uniform.

The procedure for approving the modified layouts of the playing and/or warm-up uniform is identical to the one specified in paragraph 24.4 of article 24 of these Regulations.

- 24.6.** Opponent Clubs should agree among themselves in written form (via e-mail) the color of playing uniform at least three (3) calendar days prior to each Match. Host Club has the priority in changing colors of their playing uniform for every Match (light or dark).

After reaching an Agreement, the Host Club shall notify the League in written form (via e-mail) not later than forty-eight (48) hours prior to the start of the Match on agreed with Opponent Club colors of playing form for every Match.

For violation, a fine in the amount of one hundred thousand (100,000) RUB will be imposed on the Club.

- 24.7.** If the team participates in the Match in a uniform of a different color after having agreed on the colors of playing form in writing, or if colors of playing uniform of the Opponent Clubs completely match or are not contrast, Commissioner may demand from Host Club to change playing form.

If a Club that has violated the written agreement of the Clubs on the color of the game uniform cannot provide its team with a different color before the official start time of the Match, the Club that has committed such a violation will be **fined from five hundred thousand (500,000) RUB to one million (1,000,000) RUB**; in addition to the fine, the Club's team may not be allowed to participate in the Match and in this case it will be credited with a loss by "FORFEIT".

- 24.8.** During the warm-up (30 minutes prior to the Match) players should be in the playing/warm-up uniform approved by the League.

For violation, a fine in the amount of one hundred thousand (100,000) RUB will be imposed on the Club for each player.

- 24.9.** During presentation prior to the Match players should be in the unique playing or warm-up uniform approved by the League.

For violation, a fine in the amount of one hundred thousand (100,000) RUB will be imposed on the Club for each player.

- 24.10.** Players' playing uniform and shoes have to be transported in hand luggage on the airplane. Playing uniform and shoes shall not be checked-in.

For violation, a fine in the amount of one hundred thousand (100,000) RUB will be imposed on the Club for each player.

ARTICLE 25 OUTFIT OF THE PLAYERS

- 25.1. T-shirts of the Players**

- 25.1.1.** Numbers on T-shirts of the players can be 0 and 00, and also from 1 to 99.



VTB UNITED LEAGUE REGULATIONS

SEASON 2020-2021

25.1.2. Shirts must be of the same dominant color in front and back. It is allowed to have shirts with sleeves which must end before elbow. Long sleeved shirts are not permitted. Shirts must be tucked into shorts.

For violation, a fine in the amount of one hundred thousand (100,000) RUB will be imposed on the Club for each player.

25.1.3. **From the front**, the t-shirt shall meet the following requirements:

- the logo (name) of the manufacturer can be placed, but its dimensions shall not exceed twenty (20) sq.cm. It shall be located in the upper right corner on the T-shirt.
- the Club logo shall be placed in front in the upper corner, preferably next to the manufacturer's logo, but its dimensions shall not exceed twenty-five (25) sq.cm.
- the League logo with the size of thirty-six (36) sq.cm (6x6 cm) shall be placed in the upper left corner above the player's number or above the Club name in the front part on the T-shirt and be clearly visible.
- the player's number with a height of ten (10) cm shall be placed in front on the T-shirt in the center and be clearly visible.
- name of the Club in English or Club sponsor's advertisement shall be placed in front part of a T-shirt below player's number and consist of written text or Club sponsor's logo with a total length not exceeding forty (40) cm. If name of the Club is displayed in one line, height of letters should not exceed eight (8) cm, if text occupies two lines of letters, the height should not exceed six (6) cm at each line;
- Advertisement of the Club sponsor under the Club's name or Club sponsor's advertisement (placed instead of the Club's name) is allowed provided that the name (text) or logo of the sponsor does not exceed eight (8) cm in height and forty (40) cm in length.
- Any other texts and logos on the front part of the T-shirt shall be at least five (5) cm from the player's number.

For violation, a fine in the amount of one hundred thousand (100,000) RUB is imposed on the Club for each Player.

25.1.4. **From the back**, the t-shirt shall meet the following requirements:

- The flag of the country, which the Club represents, shall be placed above the player's name in the size 2.5x1.5 cm;
- The player's surname in English shall be placed below the flag and occupy only one (1) line of text. The height of the inscription shall be at least six (6) cm and not more than eight (8) cm;
- advertisement of the Club's sponsor below the Player's name is allowed only if size of name (text) or sponsor's logo shall not exceed six (6) cm in height and twenty-five (25) cm in length;
- the player's number not less than eighteen (18) cm in height shall be placed in the center and shall be clearly visible;
- Club sponsor's advertising under the number of a player is allowed if it does not exceed forty (40) cm in length and it may consist of:
 - Club sponsor's logo not exceeding eight (8) cm in height;
 - Club sponsor's name (text) not exceeding eight (8) cm in height when text occupies one line and not exceeding six (6) cm in height in each line when text occupies two lines.



VTB UNITED LEAGUE REGULATIONS

SEASON 2020-2021

- any other inscriptions and logos shall be at least three (3) cm from the player's number according to Annex 4 to these Regulations.

For violation, a fine in the amount of one hundred thousand (100,000) RUB is imposed on the Club for each Player.

25.2. Players' shorts

25.2.1. Shorts must be of the same dominant color in front and back, same as the shirt color.

For violation, a fine in the amount of one hundred thousand (100,000) RUB is imposed on the Club for each Player.

25.2.2. Shorts shall meet the following requirements:

- logo of the manufacturer can be placed on the front part of shorts on the right or left part, but its dimensions shall not exceed twenty (20) sq.cm. It shall be located at the bottom edge of the shorts;
- Club's logo can be placed on the front part of shorts if its size does not exceed twenty-five (25) sq.cm; it shall be placed at the bottom edge next to manufacturer's logo;
- advertising of the Club's sponsor can be placed in the front on right or left, but its size shall be no more than thirty (30) sq.cm for each advertising;
- advertising of the Club's sponsor on shorts from behind is allowed, but not more than eight (8) cm in height and forty (40) cm in length.

For violation, a fine in the amount of one hundred thousand (100,000) RUB is imposed on the Club for each Player.

25.3. Players' Socks

25.3.1. The logo (name) of the manufacturer can be placed, but its dimensions shall not exceed twenty (20) sq.cm.

25.3.2. In accordance with FIBA Official Basketball Rules (subcl. 4.3.1 of cl. 4.3 of art. 4), socks shall be of the same dominant color for all players of the team. Socks should be visible.

25.3.3. Advertising on socks is prohibited.

For violation of clauses, a fine in the amount of one hundred thousand (100,000) RUB is imposed on the Club for each Player.

25.4. Players' Warm-up uniform

25.4.1. Warm-up uniform (warm-up T-shirt with short/long sleeve and warm-up pants) shall comply with the following requirements:

- playing number (not exceeding ten (10) cm in height), which should correspond to the Player's number on his playing uniform, can be placed in the front of the warm-up T-shirt with short/long sleeve and warm-up pants;
- logo of the manufacturer can be placed on the warm-up T-shirt with short/long sleeve and warm-up pants in the front, but its dimensions should not exceed twenty (20) sq.cm.
- logo of the Club can be placed on a warm-up T-shirt with short/long sleeve and warm-up pants next to logo of the manufacturer, but its dimensions shall not exceed twenty-five (25) sq.cm.
- name of the Club in English or an advertisement of the Club's sponsor can be placed on a warm-up T-shirt with short/long sleeve in the front and consist of written text with a total length not exceeding forty (40) cm. If name (text) of the Club or Club's sponsor occupies one line, height of letters shall not exceed eight (8) cm, if text occupies two lines, height of letters in each line should not exceed six (6) cm;



VTB UNITED LEAGUE REGULATIONS

SEASON 2020-2021

- advertising of the Club's sponsor is allowed in the front of warm-up T-shirt with short/long sleeve if dimension of the name (text) or logo of the sponsor shall not exceed eight (8) cm in height and forty (40) cm in length;
- Club sponsor's advertising is allowed on the back of a warm-up T-shirt with short/long sleeve (not more than two (2)), if it occupies one line, the height of letters shall not exceed eight (8) cm in height and forty (40) cm in length. If text occupies two lines, height of letters in each line should not exceed six (6) cm in height and forty (40) cm in length.
- advertising on warm-up pants is allowed. The placement location and size of the name (text) or logo of the Club sponsor are agreed by the Club and the League when approving the layout of the warm-up uniform.

For violation, a fine in the amount of one hundred thousand (100,000) RUB is imposed on the Club for each Player.

25.5. Players' Shoes

- shoes may be of any color but left and right must be of the same color. No flashing lights, reflective material or other adornments are permitted on shoes.
- advertising on shoes is prohibited.
- the logo (name) of the manufacturer can be placed, but its dimensions shall not exceed twenty (20) sq.cm.

For violation, a fine in the amount of one hundred thousand (100,000) RUB is imposed on the Club for each Player.

25.6. Other outfit of Players

25.6.1. Use of other outfit of Players (compression sleeves, knee pads, headbands and other) is allowed and shall comply with the requirements of FIBA Official Basketball Rules (subcl. 4.4 of art. 4). In particular, the following items are permitted: compression (padded) sleeves; colorless guard for the jaw; tape for hands, shoulders, legs, etc., headband, wristband, sleeve protectors, etc., but of the same entire color for all team players.

25.6.2. Placement of advertising on other equipment (compression sleeves, knee pads, headbands and other) is prohibited.

25.6.3. The logo (name) of the manufacturer can be placed, but its dimensions shall not exceed twenty (20) sq.cm.

For violation of clauses 25.6.1., 25.6.2., 25.6.3. of art. 25 a fine in the amount of two hundred thousand (200,000) RUB is imposed on the Club for each Player, who violated the corresponding clause.

25.7. Requirements to equipment (playing and warm-up) are additionally presented in Annex No. 4 to these Regulations in the format of illustrations.

ARTICLE 26 OUTFIT OF REFEREES, COMMISSIONER AND TABLE OFFICIALS.

26.1. Referees

26.1.1. The uniform of Referees shall consist of a warm-up jacket (sweatshirt, jumper, etc.), T-shirt, long black trousers, black socks and black shoes.

26.1.2. The League provide Referees with warm-up jackets (sweatshirts, jumpers, etc.) and T-shirts at the rate of one (1) warm-up jacket (sweatshirt, jumper, etc.) and two (2) T-shirts for one (1) Referee. Use by Referees of any other warm-up jackets and sweatshirts, etc.) and T-shirts is prohibited at Championship Matches



VTB UNITED LEAGUE REGULATIONS

SEASON 2020-2021

- 26.1.3.** Referee's jacket (sweatshirt, jumper, etc.) and T-shirt shall be unified for everyone for all the Referees serving the Championship.
- 26.1.4.** The League's logo with the size of thirty-six (36) sq.cm (6x6 cm) shall be placed at the top on the left side of the warm-up jacket (sweatshirt, jumper, etc.) and Referee's T-shirt.
- 26.1.5.** The logo (name) of the manufacturer can be placed, but its dimensions shall not exceed twenty (20) sq.cm.
- 26.1.6.** Placement of advertisement on the uniform of Referees is determined by the League. Placement of other advertising on the uniform of Referees is prohibited.
- 26.2. Table Officials**
- 26.2.1.** The uniform of the Table Officials shall consist of a jacket (sweatshirt, sweater, etc.), a polo shirt.
- 26.2.2.** The League provide Table Officials with at least fifteen (15) jackets (sweatshirts, jumpers, etc.) and polo shirts and at least fifteen (15) polo shirts for one (1) Club. Use by Table Officials of other jackets (sweatshirts, jumpers, etc.) and T-shirts is prohibited at Championship Matches.
- 26.2.3.** Table Officials shall be at the Referee's table in a unified form provided by the League or either all Table Officials should wear jackets (sweatshirts, jumpers, etc.) or T-shirts.
- 26.2.4.** The League's logo with the size of thirty-six (36) sq.cm (6x6 cm) shall be placed at the top on the left side of the jacket (sweatshirt, jumper, etc.) and Table Official's polo shirt.
- 26.2.5.** Placement of advertising on the uniform of Table Officials is determined by the League. Placement of other advertising on the uniform of Table officials is prohibited.
- 26.3. Commissioner**
- 26.3.1.** A Commissioner shall be dressed in a business suit (jacket, trousers, shirt and tie).
- 26.3.2.** Commissioner provides business suit at his/her own.
- 26.3.3.** Ad placement on a suit is prohibited.
- 26.4. Playing court cleaning staff**
- 26.4.1.** Playing court cleaning staff during the game shall be dressed in a unified bright color uniform.
- 26.4.2.** Uniform of playing court cleaning staff is provided by the Host Club. Ad placement on the uniform of playing court cleaning staff is prohibited.



VTB UNITED LEAGUE REGULATIONS

SEASON 2020-2021

CHAPTER 5

CHAMPIONSHIP SYSTEM, TIME AND PLACE OF MATCHES,

AWARDING

ARTICLE 27 PARTICIPANTS AND SYSTEM OF CHAMPIONSHIPS

- 27.1. Participants are approved by the Board of the League and are specified in Annex No. 9 to the Regulations.
- 27.2. Dates of the Championship are from September 20, 2020 to June 15, 2021.
- 27.3. Championship schedule shall be approved by the Board of the League.
- 27.4. Schedule of Matches shall be developed by the League together with Clubs under Schedule Plan approved by the Board of the League and shall be approved by Directorate.
- 27.5. Championships will be held in two stages:
- Regular Championship
 - Play-off
- Note:** In case of occurrence of force majeure circumstances impeding the conduct of the Championship, including in connection with a change in health situation due to the new coronavirus infection (COVID-19), and/or pandemic coronavirus infection (COVID-19), the Directorate has the right to decide to suspend the Championship for a period specified by the Directorate, and the League Board has the right to decide on the early termination of the Championship at any stage of the Championship and determine the final classification of teams based on the results as of the date of the last played Championship match, with the assignment of the title "VTB United League Champion" if it is possible to comply with the sports principle to determine the champion (the Regular Championship is completed, teams have played an equal number of games, etc.) or without assignment of the title of "VTB United League Champion" if it is impossible to comply with the sports principle for defining the champion (the Regular Championship has not been completed, the teams have played an unequal number of planned games, etc.). In this case, the final classification of teams is determined by the rules of article 28 of these Regulations.
- 27.6. **Regular Championship**
- 27.6.1. In the Regular Championship, teams play a "everyone with each" round-robin system for one (1) game at home and away. Matches are held in two (2) rounds (home and away) without dividing into groups. Regular Championship consists of twenty-six (26) rounds. All games of the last round of the Regular Championship can be scheduled to be held on one (1) day with the same tip-off time.
- 27.7. **Play-Off**
- 27.7.1. Eight (8) best teams of the Regular Championship will qualify to Play-off and play according to elimination system up to three (3) victories (scheme 2+2+1). Each team will get a number depending on their place after Regular Championship. The team winning a higher place in the Regular Championship will get advantage of the home court at every stage of Play-off. The first and third games, if necessary, will be held at the court of the team that has an advantage. The second game will be held at the opponent's court. Play-off consists of three stages:
- quarter final;
 - semi-final;



VTB UNITED LEAGUE REGULATIONS

SEASON 2020-2021

- final.

27.7.2.

Quarter-final

Eight (8) teams will be divided in pairs, compete in Matches up to three (3) victories. Pairs shall be made up according to the following principle: team with the higher number based on results of the Regular Championship will play against the team with the lowest number based on results of the Regular Championship (for example: 1–8, 2–7, 3–6, 4–5).

27.7.3.

Semi-final

Four (4) teams, winners of the quarter-final, will be divided in pairs, compete in Matches up to three (3) victories. Pairs shall be made up according to the following principle: the team with the higher number based on results of the Regular Championship among the four (4) participating semi-final teams will play against the team with the lowest number based on results of the Regular Championship among four (4) teams participating in semi-final (for example: 3–8, 4–7 or 1–4, 2–3 or 1–7, 5–6, etc.).

27.7.4.

Final

Two (2) teams, winners of the semi-final, play until three (3) victories.

ARTICLE 28 TEAMS CLASSIFICATION IN THE CHAMPIONSHIP

Teams in the Championship are classified in accordance with section "D" of the FIBA Official Basketball Rules.

28.1

Team classification during the Regular Championship

28.1.1

Teams are classified on the basis of points in accordance with the indicators of their victories and losses, namely: two (2) points for each won game, one (1) point for each lost game (including "due to a lack of players" loss) and zero (0) points for a game lost by "FORFEIT".

28.1.2

If two (2) or more teams have the same number of points in accordance with their wins and losses as a result of all games in the group, then the results of games between these two (2) or more teams are used for classification. If two (2) or more teams have an equal number of points in accordance with the indicators of their wins and losses from the results of games among themselves, then additional criteria are applied in the following order:

- The best difference in the shoot and missed balls in the games between them.
- The greatest number of shoot balls in the games between them.
- The best difference in the shoot and missed balls in all games between them.
- The greatest number of shoot balls in all games in the group.

If, using these criteria, equality still holds, then the lot is used to classify the teams.

28.1.3

In the event that not all teams have played all their games in Regular Championship and two (2) or more teams have an equal number of points in accordance with the indicators of their wins and losses, then the best difference of the shoot and missed balls in all games of the given teams played for the current moment.

28.2

Teams classification as per Championship results

28.2.1

The team winning the Final ranks the first (1st).

28.2.2

The team losing the Final ranks the second (2nd).

28.2.3

Teams losing in ½ of the Final rank the third (3rd)–fourth (4th) places. A higher place will be awarded to the team which a higher place in the Regular Championship.

28.2.4

Teams losing in ¼ of the Final rank fifth (5th) – eighth (8th) places. A higher place will be awarded to the team which a higher place in the Regular Championship.



VTB UNITED LEAGUE REGULATIONS

SEASON 2020-2021

- 28.2.5** Teams that did not qualify to Play-off in the overall classification, receive a place which they were awarded per results of the Regular Championships.
- Note:** If the League Board decides to end the Championship prematurely for reasons of force majeure, including changes in the sanitary and epidemiological situation due to a new coronavirus infection (COVID-19) and/or a coronavirus pandemic (COVID-19) that prevent the Championship, in this case, the final classification of teams is determined by the results on the date of the last played match of the Championship, with or without assignment of the title of "VTB United League Champion".
- 28.3** **Determination of the results of the Russian Championship (for Russian Clubs).**
- 28.3.1** According to the results of the Championship, the places of Russian Clubs in the Russian Championship are distributed according to the provisions of the "United League" Russian basketball Championship Regulations among men's teams of sports clubs for the seasons 2019–2020, 2020–2021, 2021–2022, 2022–2023, approved by the RBF Executive Committee on the representation of the League.
- The best Russian Club at the end of the Championship becomes the Champion of Russia, unless otherwise established by the regulations of the "United League" Russian basketball Championship Regulations among men's teams of sports clubs for the seasons 2019–2020, 2020–2021, 2021–2022, 2022–2023. Other Russian Clubs are classified in the Russian Championship depending on their place in the Play-off series or Regular Season, if the team did not make it to the Play-offs. If two teams finished participating in the Championship at the same stage of the Play-offs, the team that finished at a higher place in the Regular Season will also have a higher place in the final classification.

ARTICLE 29 DATE AND PLACE OF THE MATCHES. START TIME.

- 29.1** Matches will be staged according to Matches schedule approved by Directorate and only in that sports facility that was declared by the Club in the course of licensing (Article 8 of the Regulations).
- 29.2** Start time of Championship Matches:
- on weekdays – not earlier than 17.00 and no later than 21.00 local time;
 - on weekend and holidays – not earlier than 13.00 and no later than 21.00 local time;
- 29.3** The Host Club shall notify the League on the expected start time of Match no later than thirty (30) calendar days before the date of the Championship.
- For violation, a fine in the amount of one hundred thousand (100,000) RUB is imposed on the Club.**
- 29.4** The final decision on the start time is taken by the League. The League shall notify Clubs on the start time at least ten (10) days prior to the Match. The Host Club is responsible for ensuring that the Game starts at the time scheduled and has no right to change it without the relevant decision of the League.
- In the event of a violation, five hundred thousand (500,000) RUB is imposed on the Club.**
- 29.5** The Guest Club takes the responsibility to secure start time of the Championship Match approved by the League. Guest Club shall arrive to the Match venue at least before the Match or before 10.00 in the morning on the Match day if they travel by train or by car.
- In case of late arrival for the start time of the Match, the Guest Club will be subjected to disciplinary measure according to Article 68 of these Regulations.



VTB UNITED LEAGUE REGULATIONS

SEASON 2020-2021

- 29.6** Possible changes and delays in the travel of a Guest Club can be caused by adverse weather conditions proved by documents or other force majeure circumstances. In these situations, the Host Club should do everything possible to stage the Match even if delayed by twenty-four (24) hours from the moment of officially scheduled start of the Match. In this case, the League should approve new start time of the Match.
- 29.7** The Guest Club has to constantly inform the League and the Host Club over the phone on the issues that arose in the course of traveling and advise date and time of suggested arrival.
- 29.8** In case Match was obstructed and as a result, claims arise against one party on financial expenditures, these claims will be subjected to consideration by Directorate. If obstruction of the Match happened due deliberate actions, payment documents proving expenditures can be presented to the party responsible and stricter sanctions can be imposed in terms of monetary penalty and even exclusion of this Club from Championship participants can be considered.

ARTICLE 30 GAME DATE SHIFTING

- 30.1** Date and place of a Championship Match, approved in the Games Schedule can be changed by the Directorate only in the following exceptional cases:
- due to participation of teams in European club competitions;
 - on request of TV company to change the date of broadcasting of the Match;
 - due to unforeseen and force majeure circumstances;
 - with the aim to optimize Games Schedule;
 - In case of restrictive measures affecting holding of sports competitions established by the authorities (e.g. prohibition of sports events, prohibition of entry into the country of the match, quarantine measures upon return from the country of the match/upon entry to the country of the match);
 - in case of shortage of players in the Club for the Match - less than 5 (five) players - as a result of the positive test for COVID-19 and/or the quarantine measures introduced in respect of players related to COVID-19.
- 30.2** The Club initiating change of the date of the Championship Match (excluding cases provided for in the subp. 5 and 6 of the p. 30.1 of Article 30 of these Regulations), not later than fifteen (15) days before the Match date shall submit a written request to the League to postpone this Match date and indicate the new date and time and the reason for the change. Club initiating change of the date has to attach a written confirmation of the approval by the Opponent Club of the new Match date to their request to the League. Requests of the Clubs to change the date and time of the Match without written confirmation of the agreement by Opponent Club to a new date of the Match will not be accepted and considered by the League.
- After receiving a new date of the Championship Match agreed by both Clubs, Directorate shall, within three (3) days, inform the Clubs in writing of its decision on this matter.
- For violation, a fine in the amount of five hundred thousand (500,000) RUB is imposed on the Club.**
- 30.3** In the event any disagreement arises between the Clubs regarding the new date of the Match, the Directorate takes final decision. Clubs are required to hold a game at the date and time approved by the Directorate.



VTB UNITED LEAGUE REGULATIONS

SEASON 2020-2021

A fine in the amount of five hundred thousand (500,000) RUB is imposed on the Club that failed to fulfill the decision of the Directorate.

- 30.4** In the event of a change of Match date or place (city or other sports facility) where the Championship Match will take place, the Club, initiator of changes shall reimburse the Guest Club, the League and other persons all documented expenses incurred in connection with the shifting of this Match including organization of refereeing.
- 30.5** In case of restrictive measures affecting holding of sports competitions established by the authorities (e.g. prohibition of sports events, prohibition of entry into the country of the match, quarantine measures upon return from the country of the match/upon entry to the country of the match), as well as in case of shortage of players in the Club - less than 5 (five) players - as a result of the positive test for COVID-19 and/or the quarantine measures introduced in respect of players related to COVID-19, the Club must inform the League in writing (with attachment of documents, confirming such information)
- 30.5.1** Such information must be submitted to the League immediately, but latest 48 (forty-eight) hours before the start of the Match. In this case, the Directorate shall have the right (but not more than 2 (two) times for each Match, once on the initiative of each Club-participant of such Match):
- to change the date of the Match upon agreement with the clubs-participants of such Match, or
 - to change the place of holding of the Match (to change of place of holding of the home and away matches of rival clubs with the preservation of the dates) upon agreement with the clubs-participants of such Match or
 - upon agreement with the clubs-participants of such Match, provide for holding of the home Match for the host Club in other sports facility declared by the Clubs-participants of the Championship (for example, the host Club shall have the right to hold the Match in the sports facility of the rival Club, hereby remaining responsible for organization of the Match in such sports facility and for all related expenses imposed on the host Club by this Regulation. Such a Match will be considered for the host Club as a home match).
- If there emerge differences between the Clubs on the issue of the new date, time and place of holding of the Match, the final decision shall be made by the Directorate. The Clubs shall hold the Match on date, start time and at the place of the Match appointed by the Directorate. A fine of 500,000 (five hundred thousand) rubles shall be imposed on the Club that failed to fulfill this decision of the Directorate. The rules of Article 70 of this Regulation shall be applied to the Club that failed to appear for the Match on the date, start time and at the place of the Match.
- 30.5.2** If the information referred to in this paragraph arises and/or comes to the League, **less than 48 (forty-eight) hours before the start of the Match**, the provisions of Article 70.2 of this Regulation shall be applied

ARTICLE 31 CHANGE OF THE MATCH START TIME

- 31.1** Match kick-off can be changed by the League only in the following exceptional cases:
- On request of TV Company to change time of Match broadcasting;
 - Due to unforeseen and force majeure circumstances.

ARTICLE 32 AWARDS. PREMIUMS. INSURANCE

- 32.1** Awards following the results of the Championship.



VTB UNITED LEAGUE REGULATIONS

SEASON 2020-2021

32.1.1 The Club which took the first (1st) place in the Championship is awarded the title of VTB United League Champion. The Club is awarded with the Cup. Club Players, Coach, Assistant Coach and Team Followers (not more than thirty (30) people) are awarded with Medals. The awards ceremony is held by the League on the playing court of the final game.

Note: If the League Board decides to end the Championship ahead of schedule due to force majeure circumstances, including in connection with a change in the sanitary and epidemiological situation due to a new coronavirus infection (COVID-19) and/or a coronavirus infection (COVID-19) pandemic hindering the Championship, in this case, if it is possible to comply with the sports principle to determine the champion (the Regular Championship is completed, the teams have played an equal number of games, etc.), the League Board additionally decides on awarding the title “VTB United League Champion”, on awarding medals and a cup, and if it is impossible to comply with the sports principle to determine the champion (the Regular Championship has not been completed, teams have played an unequal number of planned games, etc.), the League Board additionally decides not to award the title of “VTB United League Champion”, not to award medals and a cup.

32.1.2 Players, Coaches, Assistant Coaches and Team Followers (not more than thirty (30) people) of the Club that takes the second (2nd) place is awarded with medals. The awarding ceremony is held by the League on the playing court of the final game.

Note: If the League Board decides to end the Championship prematurely for reasons of force majeure, including changes in the sanitary and epidemiological situation due to a new coronavirus infection (COVID-19) and/or a coronavirus pandemic (COVID-19) that prevent the Championship from being held, in this case, medals will not be awarded.

32.1.3 During the Championship memorable prizes are awarded to:

- MVP (Most Valuable Player) of the month (October, November, December, January, February, March, April, May): determined based on the player's statistics and the results of his team at the end of the calendar month.
- MVP (Most Valuable Player) of the Regular Championship: determined based on the player's statistics and the results of his team at the conclusion of the Regular Championship.
- MVP (Most Valuable Player) of the Final: determined based on the statistics of the player from the winning team at the end of the final game.
- Coach of the Year: determined on the basis of the result of the coach's team at the conclusion of the Regular Championship.
- Young player of the year: determined based on the statistics of the young player (up to 23 years) at the conclusion of the Regular Championship.
- The sixth player of the year: determined based on the statistics of the benchwarmer (who started more than 50% of games played on the bench) at the conclusion of the Regular Championship.
- Defending player of the year: determined based on the statistics of the player at the conclusion of the Regular Championship.

Memorable prizes are awarded based on the decision of the Directorate.

By the decision of the Directorate, additional commemorative prizes can be established for Players, Coaches, Officials and Team Followers, and directly for Clubs participating in the Championship.

32.2 **Awards following the results of the Russian Championship (for Russian Clubs).**

32.2.1 Awards based on the results of the Russian Championship (for Russian Clubs) are made in accordance with the regulations of the "United League" Russian basketball Championship



VTB UNITED LEAGUE REGULATIONS

SEASON 2020-2021

Regulations among men's teams of sports clubs for the seasons 2019–2020, 2020–2021, 2021–2022, 2022–2023, approved by the RBF Executive Committee.

32.3

Bonus remuneration

According to the results of the Championship games, participating Clubs receive bonus remuneration, as provided in Annex 10 to these Regulations.

32.4

Insurance

The League provides insurance for players of Clubs participating in the Championship on the terms and conditions set out in Annex 11 to these Regulations.



VTB UNITED LEAGUE REGULATIONS

SEASON 2020-2021

CHAPTER 6

CLUBS RESPONSIBILITY FOR STAGING MATCHES OF THE CHAMPIONSHIP

ARTICLE 33 CLUBS RESPONSIBILITY FOR STAGING MATCHES OF THE CHAMPIONSHIP

33.1 GENERAL TERMS

33.1.1 The Host Club is responsible for organizing and holding home Championship Matches and performs obligations provided for in this chapter for the Host Club at Championship Match. The Host Club will meet expenses on lease of sport facility for staging home Championships Matches and training of their team and visiting teams.

33.1.2 The Host Club shall ensure that sport facility will be completely ready at least one (1) hour before start of the Match according to requirements of FIBA Official Basketball Rules, FIBA Official Basketball Rules – Basketball Equipment and these Regulations. Game clock should display countdown from sixty (60) minutes to the kick-off of the Match.

A fine in the amount of one hundred thousand (100,000) RUB will be imposed on the Club for violation.

33.1.3 Not later than sixty (60) minutes prior to the beginning of the Match representatives of both teams at the game shall give the game commissioner a technical application in two (2) copies, the Team Passport, Licenses of the Players, Coaches and the Club's Team Followers. The representative of the Host Club's team at the Match provides the Match Commissioner with a list of the Host Club's Referees-Secretaries approved by the League, and a list of the Match's Referees-Secretaries from the list of the Host Club's Referees-Secretaries approved by the League.

Players' readiness for the Game and the absence of medical contraindications and medical eligibility to the Match shall be confirmed by the signature of the Representative of the team at the Match the team doctor in the Technical entry.

33.1.4 Not later than ten (10) minutes prior to the start time, Coaches of both teams shall confirm their agreement with the names and corresponding numbers of the Team Players and the names of the Coaches by signing the official scoresheet in front of their surnames. They shall also specify five (5) players who will start the Game, and indicate the name of the team captain on the playing court. The Coach of the Host Team is the first to provide the above information.

33.1.5 Match shall start exactly at scheduled time. The Host Club shall present to Match Commissioner and Guest Club Pre-Match time-table one (1) hour before start of the Match.

An example of pre-Match time-table for the Match which starts at 19.00:

Teams enter the warm-up area 18.30:00 / 30 minutes prior

Sound signal. Teams go to benches 18.53:00 / 7 minutes prior

The league's audio clip sounds 18.53:30 / 6.30 minutes prior

Guest Team presentation 18.54:00 / 6.00 minutes prior

Host Team presentation 18.55:00 / 5.00 minutes prior

Final warm-up 18.57:00 / 3 minutes prior



VTB UNITED LEAGUE REGULATIONS

SEASON 2020-2021

Teams go back to benches	18.58:30 / 1.30 minutes prior
Teams enter the playing court:	18.59:30/30 seconds prior
Start of the Match:	19.00:00

The anthems of countries represented by clubs are not played.

Teams shall come to the playground separately from each other.

The referees shall come to the playground separately from the teams.

It shall not be allowed to hold a pre-match show with performances of artists and creative teams on the playground. As a pre-match show, the Club is recommended to organize light and sound performances, video shows, etc.

Additional activities shall be agreed with the League.

There shall be no handshake between the players of participating teams, referees and other persons.

Note: If the Host Club plans to hold any ceremonies or shows during the Match, such ceremonies or shows shall be reflected in the above schedule.

For violation, a fine in the amount of one hundred thousand (100,000) RUB is imposed on the Club.

Changes possible to pre-Match time-table agreed with the League on organization of a ceremony or a show prior to the Match.

33.2 A team cannot under any pretext refuse to hold the Game or delay its start if the Referees demanded to start the game. Any refusal to follow the instructions of the Referees can be considered as a failure to appear of the team.

33.3 The only persons who can be in the zone of the playing court, including the bench, are the Players and the Club's Team Followers, which are indicated in the technical application for the game.

The Commissioner has the right to demand that any person who does not meet these conditions leave the team bench or the area close to it. The Commissioner has the right to demand that any disqualified person leave the team bench.

For violation of the rules of being on the team bench or in the area of the team bench, the Club is fined one hundred thousand (100,000) RUB for each infringer.

33.4 Players, the Coach and the Assistant Coach listed in the official Match Protocol shall be present at the presentation of the teams before the start of the game. Persons not listed in the official scoresheet may not be present at the presentation of the teams before the start of the game.

For violation, a fine in the amount of one hundred thousand (100,000) RUB is imposed on the Club.

33.5 The Coach and the Assistant Coach shall wear business suit (jacket, trousers, shirt).

For violation, a fine of one hundred thousand (100,000) RUB is imposed on the Club for each Coach and/or Assistant Coach for each game.

33.6 A Coach or Assistant Coach (but only one of them at any time) is allowed to stand during the Game. A Coach or an Assistant Coach may verbally refer to the Players during the Game provided that he remains within the zone of his team's bench.

33.7 Only persons included in the Match Technical entry may approach the Referees table during the Match for statistical information **only at the time when the ball is "dead" and the game clock is stopped.**

33.8 After the end-of-the-game signal of the game clock (0:0 on the game clock), persons included in the Match Technical Entry shall leave the venue and not enter into wrangling with opponents, Match Officials (Commissioner, Referees, Table Officials) or spectators.



VTB UNITED LEAGUE REGULATIONS

SEASON 2020-2021

For a violation, a fine in the amount of one hundred thousand (100,000) RUB for each person included in the Match Technical Entry will be imposed on the Club.

33.9

After every disqualification of a Player, a Coach or an Assistant Coach, in accordance with FIBA Official Basketball Regulations, he/she should leave playing court and go to a dressing room of his/her team and stay there during the entire Game, or he/she may leave the building. For violation, the Club having such a Player, Coach or Assistant Coach included in the Team Passport, will be **fin ed in the amount of two hundred thousand (200,000) RUB** for each Player and/or Coach and/or Assistant Coach.

ARTICLE 34 OBLIGATIONS OF A HOST CLUB WHEN CARRYING OUT MATCHES

Obligations of the Host Club in relation to the Guest Club

34.1

Transport

34.1.1

The Host Club shall provide a comfortable bus (the availability of a system of forced ventilation or air conditioning with the possibility of individual adjustment, the presence of a heating system, folding armchairs with footrests, a spacious luggage compartment, the availability of working seat belts in each seat, a capacity of at least forty (40) seats) sufficient to accommodate the entire delegation of the Guest Club, for the meeting of the Guest Club at the railway station or at the airport of a city where the Game takes place, delivery to the hotel, for workouts, games and back to the hotel, sending to the train station or to the airport.

For violation, a fine in the amount of two hundred thousand (200,000) RUB is imposed on the Host Club.

34.1.2

The Guest Club does not have the right to demand from the Host Club transport for a meeting at the railway station or at an airport not located in the city where the Championship Game is held (or in its immediate vicinity). In this case, the Guest Club shall independently get to the city where the Game is held.

34.2

Accommodation and purchase of return tickets

34.2.1

The Guest Club is entitled to request the Host Club to book rooms in the hotel submitting preliminary application and accompanying letter. In this case, the Host Club shall book rooms in the hotel having previously agreed the cost of accommodation with the Guest Club. The Guest Club shall pay for their accommodation on its own.

34.2.2

The Guest Club is entitled to request the Host Club to book return tickets submitting preliminary application and accompanying letter. The Guest Club shall pay for their return tickets on its own.

For violation clauses 34.2.1–34.2.2 of Article 34 of these Regulations, a fine in the amount of one hundred thousand (100,000) RUB is imposed on the Club for each clause.

34.2.3

A preliminary application from the Guest Club to the Host Club for reservation of hotel rooms and purchase of return tickets shall be submitted at least fourteen (14) days prior to the Match day. For Play-off series the request should be submitted not later than on the next day after the last Match in the series.

If the preliminary application is not submitted or submitted late, the Guest Club decides on accommodation and purchase of return tickets independently.

34.3

Playing court for training and warm-up before the Game



VTB UNITED LEAGUE REGULATIONS

SEASON 2020-2021

- 34.3.1** The Host Club shall provide the Guest Club with a playing court on which the Game takes place, for training at least twice within twenty-four (24) hours before the start of the Championship game according to the following rules:
- one (1) training in the evening before the game (at least one (1) hour). Start of training shall not differ by more than one (1) hour from the time when the Game is to be held. For example, if the start time of the Game is at 19.00, then the training shall start between 18.00 and 21.00.
 - one (1) training in the morning before the game (at least one (1) hour). The time of training on the Game day shall be distributed so that session of the Guest Club ended no later than five (5) hours before the Match.
 - The Guest Club has priority to choose time of the training.
- 34.3.2** In exceptional cases, Clubs may use for training a playing court that is not a playing court of a sport facility, venue of the Match (**but only on the day preceding the date of Match**), if this occurs for justified reasons and approved by the League. In this case, such a sports facility shall meet the requirements set forth in these Regulations.
- 34.3.3** The Host Club should provide access to sport facility at least 1 hour 30 minutes before scheduled start of the Match. The Host Club shall provide the Guest Club with a playing court where the League Match will take place, for warm-up at least one (1) hour before the start of the Game.
- 34.3.4** The Host Club shall provide at least twelve (12) official balls to the Guest Club during training sessions and six (6) balls during warm-up before the game.
- For violation of clauses 34.3.1–34.3.4 of Article 34 of these Regulations, a fine in the amount of one hundred thousand (100,000) RUB is imposed on the Host Club for each clause.**
- 34.4 Other obligations of the Host Club.**
- 34.4.1** The Host Club shall provide still mineral water to the Guest Club at the rate of thirty (30) bottles of one (1) liter for the Match and each training.
- For violation, a fine in the amount of one hundred thousand (100,000) RUB and compensation of expenses of the Guest Club for the purchase of water will be imposed on the Host Club.**
- 34.4.2** The Host Club shall provide the Guest Club with at least ten (10) kilograms of ice for the Match and for each training session.
- For violation, a fine in the amount of one hundred thousand (100,000) RUB and compensation of expenses of the Guest Club for the purchase of ice will be imposed on the Host Club.**
- 34.4.3** The Host Club shall provide the Guest Club with a separate guarded changing room for the team that meets the requirements of clause 22.6.1. of Art. 22 of these Regulations.
- For violation, a fine in the amount of five hundred thousand (500,000) RUB will be imposed on the Host Club.**
- 34.4.4** The Host Club shall provide the Guest Club with a separate guarded changing room for Coaches that meets the requirements of clause 22.6.2. of Art. 22 of these Regulations.
- For violation, a fine in the amount of five hundred thousand (500,000) RUB will be imposed on the Host Club.**
- 34.4.5** Provide assistance to the Guest Club in relation to visa formalities. The Guest Club at its own expense pays for consular fees when issuing visas.
- Obligations towards Referees, Commissioner and Official Delegated Inspector and Table Officials**



VTB UNITED LEAGUE REGULATIONS

SEASON 2020-2021

- 34.5 Transport**
- 34.5.1** The Host Club shall provide comfortable transportation for meeting at the railway station or at the airport of the city where the Match is held of non-resident Referees, the Commissioner and the Official Delegated Inspector of the Match, and provide transfer from the airport/railway station – hotel – sport facility – hotel – airport/railway station.
For violation, a fine of one hundred thousand (100,000) RUB is imposed on the Host Club and the payment of transport expenses.
- 34.5.2** The Referees, the Commissioner and the Official Delegated Inspector do not have the right to require the Host Club to provide them with transport to meet at a railway station or at an airport not located in the city where the Championship Games are held (or in close proximity to it). In this case, the Referees, the Commissioner and the Official Delegated Inspector shall travel to the city where the Game takes place by train or bus (with a subsequent return of the travel costs by the League).
- 34.6 Other obligations**
- 34.6.1** To secure qualified operations of Table Officials.
- 34.6.2** To pay remuneration to Table Officials in the amount proposed by the Host Club but not less than two thousand five hundred (2,500) RUB per one (1) Table Official per one (1) Match. (**Note:** the rule on the amount of payment for the work of Referees-Secretaries applies only to Russian Clubs). Payment of remuneration to Table Officials shall be made according to agreements between Table Officials and Clubs.
- 34.6.3** The Host Club takes responsibility for safety of the Match Referees. It means their arrival prior to the Match, movement in the sport facility and departure from sport facility after the Match. Referees should have keys from dressing room to avoid being in the corridor for a long time. Only the Referees, the Commissioner of the Match and the Official Delegate-Inspector and the League representative are allowed to enter the Referees dressing room. This requirement shall be fulfilled by security service of the Host Club.
- 34.6.4** Provide equipment required for the Match at the disposal of Table Officials.
- 34.6.5** The Host Club shall provide still mineral water to the Referees, the Commissioner, the Table Officials and the Official Delegate-Inspector at a ratio: twenty (20) 0.5-liter bottles for the Match.
For violation, a fine in the amount of one hundred thousand (100,000) RUB is imposed on the Host Club.
- 34.6.6** The Host Club shall provide the Referees, the Commissioner and the Official Delegate-Inspector with a separate guarded changing room that meets requirements of clause 22.6.3 of Art. 22 of these Regulations, and also three terry bath towels for Referees.
For violation, a fine in the amount of five hundred thousand (500,000) RUB is imposed on the Host Club.
- 34.6.7** The Host Club shall provide Table Officials with a dressing room that meets the requirements of clause 22.6.4 of Art. 22 of these Regulations.
- 34.6.8** The Host Club shall provide the Match Commissioner with a telephone and access to Internet for working activities.
For violation, a fine in the amount of one hundred thousand (100,000) RUB is imposed on the Host Club.
- 34.6.9** To control the preparation and conduct of the Games and to comply with the requirements of these Regulations on the part of the League, the Host Club shall, upon the request of the League, sent no later than 5 calendar days before the date of the Match, provide accreditations in an



VTB UNITED LEAGUE REGULATIONS

SEASON 2020-2021

amount of no more than 4 for League employees with access to all areas of the sports facility on the day of the home match, without the right to occupy an individual spectator seat.

Additional requirements

- 34.7** The Host Club shall provide the Guest Club the opportunity to purchase at least two hundred fifty (250) tickets for their supporters at the expense of the Guest Club exclusively based on written request of the Guest Club submitted not later than fourteen (14) days before the date of the Match.

During Play-off series, request should be submitted not later than on the next day after the previous Match of the series.

The Guest Club may be refused the right to purchase requested number of tickets if they infringe the established order.

- 34.8** **Cheerleading team, club mascot, announcer/emcee and sound engineer/DJ.**

- 34.8.1** The Host Club shall ensure that there is a support group of at least six (6) people at the Match, the Host Club mascot – at least one (1) person, the announcer/presenter – at least one (1) person, the sound operator/DJ – at least one (1) person and the operator of the video screen/video club – at least one (1) person.

For violation, a fine in the amount of one hundred thousand (100,000) RUB is imposed on the Host Club for each Match.

The Host Club shall have the right to ensure the presence of a support group of at least 6 (six) people at the Match, talisman of the Host Club (Mascot) - at least 1 (one) person at the Match.

- 34.8.2** The Host Club shall arrange informing of Match participants and spectators in the sports facility by a qualified announcer/emcee. A qualified announcer/emcee cannot perform duties of announcer – a member of table officials' team simultaneously. During the Match, the announcer/emcee must notify the viewers at least twice in a quarter and once in breaks of the Match of the need to comply with the sanitary and epidemiological requirements when staying at the Sports Facility.

For violation, a fine in the amount of one hundred thousand (100,000) RUB is imposed on the Host Club for each Match.

- 34.8.3** The Host Club shall provide running music tracks during time-outs and pauses before and during the Match by a qualified sound engineer/DJ.

The Host Club shall have the right to use music or noise accompaniment simulating the presence of fans and aimed at supporting their team through sound amplification equipment during the period when the ball is in play until the ball crosses the central line of marking of the playground. Musical compositions and noise accompaniment used during the Game shall not contain profanity, insults or calls for violence, regardless of language.

The Host Club shall pay remuneration to authors of music and text of musical pieces played at Matches and remuneration will be paid to producers of phonograms. Relevant agreements with authors of music and text, producers of phonograms and/or organizations managing authors' rights and related rights shall be concluded on the collective basis. The League has the right to request supporting documents from Clubs during the season.

For violation, a fine in the amount of three hundred thousand (300,000) RUB is imposed on the Host Club for each Match.

- 34.8.4** During playing time, the cheerleading team and the mascot shall be at a distance no closer than five (5) meters from the playing court, and they shall not be in front of the advertising structures, blocking the advertising of the sponsors of the League.

For violation, a fine in the amount of one hundred thousand (100,000) RUB is imposed on the Host Club for each Match.



VTB UNITED LEAGUE REGULATIONS

SEASON 2020-2021

- 34.8.5** The cheerleading team and the mascot are not allowed to enter the playing court.
For violation, a fine in the amount of one hundred thousand (100,000) RUB is imposed on the Host Club for each Match.
- 34.8.6** A mascot can freely move around the stands with social distance recommended by the authorities
For violation, a fine in the amount of one hundred thousand (100,000) RUB is imposed on the Host Club for each Match.
- 34.8.7** During the time-outs, competitions and show programs with the participation of spectators are not allowed.
- 34.9 Use of musical instruments, microphones and sound amplifying equipment during the Match**
- 34.9.1** The Host Club shall ensure compliance with the following provisions:
1. Use of any musical instruments (horns, percussions, other instruments) by the Host Club during the Match is allowed only at the tribunes, but no closer than the tenth (10th) row (if there are less than ten (10) rows in a sport facility, then it is allowed at the last row). Use of musical instruments (horns, percussions, other instruments) in other places of a sport facility is prohibited. The sound volume of musical instruments shall adapt to the dimensions of a playing court and spectators tribunes and the noise created by spectators to a maximum sound pressure level of ninety (90) decibels, measured at a distance of one (1) meter from the sound source.
 2. Use of drums, horns and pipes by fans during the Match is allowed only at the tribunes in an active support zone, but no closer than the tenth (10th) row (if there are less than ten (10) rows in a sport facility, then it is allowed at the last row). Use of drums, horns and pipes in other places of a sport facility is prohibited. The sound volume of drums, horns and pipes shall adapt to the dimensions of a playing court and spectators tribunes and the noise created by spectators to a maximum sound pressure level of ninety (90) decibels, measured at a distance of one (1) meter from the sound source.
 3. Use of background music and microphone by announcer/emcee through sound amplifying equipment is permitted only in cases where the ball is not in the game (i.e. the ball is "dead").
Note: The Host Club shall have the right to use music or noise accompaniment simulating the presence of fans and aimed at supporting their team through sound amplification equipment during the period when the ball is in play until the ball crosses the central line of marking of the playground;
 4. Placement of sound amplifying equipment in the area of playing court, Referees table and team benches is prohibited.
 5. During the Match, the sound pressure of the musical accompaniment through the sound amplifying apparatus should not exceed one hundred (100) decibels; at the request of the Game Commissioner, the Host Club shall provide a device for measuring the sound level (in decibels).
Upon request of the Commissioner, the host Club shall volume down the musical or noise accompaniment simulating the presence of fans and aimed at supporting their team;
 6. It is forbidden to use megaphones and other portable sound amplifying equipment during Matches.



VTB UNITED LEAGUE REGULATIONS

SEASON 2020-2021

7. It is forbidden to use whistles disturbing Players during Matches (except for Referees).

For violation of clause 34.9.1 of Art. 34 of these Regulations, a fine in the amount of one hundred thousand (100,000) RUB is imposed on the Host Club for each subclause 1–7 separately.

34.10 Use of video screens and video cube, use of light effects

34.10.1

It is allowed to use video screens and a video cube to show a live TV broadcast of the Match. Replays of bright game moments of the Match (goals scored, ball passes, blocked shots, etc.) in a live TV broadcast on a video screen and video cube are allowed and shall be performed by a qualified video screen/video cube operator, who shall prevent the display of replays of game moments of the Match, that are prohibited or contradicts these Regulations.

34.10.2

The Host Club shall comply with the following requirements for the use of video screens and video cube in the sports facility:

1. use of video screens and video cube in the sports facility where the Championship Matches are held is permitted provided that it does not interfere with the normal conduct of the Match;
2. it is necessary to show the Match and its participants in a positive light;
3. it is forbidden to show moments abusing honor, dignity and business reputation of the League, its representatives, Referees, Players, Coaches, Officials and Team Followers of the Clubs, other participants of the Championship on video screens and video cube;
4. it is forbidden to use video screens and video cube to distract Players during the Match, for example, during foul shot attempts, offensive possessions, etc.
5. the image on video screen and video cube shall not be offensive to Game participants or spectators, an image on the screen cannot be displayed if its purpose and obvious effect is the incitement of fans to riots and the manifestation of aggression; it is necessary to avoid showing the participants in the Game or spectators contesting Referees' decisions that offend other participants of the Game or show offensive gestures.
6. It is forbidden to show any playing moments on video screens and video cube which may cause negative reaction from participants of the Match or spectators;
7. It is forbidden to show any moments demonstrating reaction of participants and spectators of the Match to the decision of Referees on video screens and video cube;
8. It is forbidden to show conflicts and situations which led to fighting and the fighting itself on video screens and video cube;
9. It is forbidden to show moments when Players and other participants of the Match get injuries on video screens and video cube;
10. It is forbidden to show on video screens and video cube supporters abusing participants of the Match or spectators and throwing foreign objects at the playing court.

For violation of clause 34.10.2 of Art. 34 of these Regulations, a fine in the amount of three hundred thousand (300,000) RUB is imposed on the Host Club for each subclause 1–10 separately

34.10.3

During the game, it is forbidden to use light effects directed at the playing court. Light effects can be used during minute breaks and breaks between game quarters.

For violation, a fine in the amount of one hundred thousand (100,000) RUB is imposed on the Host Club.

34.10.4

It is prohibited to use any types of light and laser devices/pointers that cause inconvenience to players during the Match.



VTB UNITED LEAGUE REGULATIONS

SEASON 2020-2021

For violation, a fine in the amount of two hundred thousand (200,000) RUB is imposed on the Host Club.

34.11 Means of support

The Host Club shall ensure that the following requirements are met:

34.11.1.

The following requirements shall be met for means of support that are allowed to be carried by spectators to Match venues without prior approval from the Host Club:

- they shall not contain political, extremist, provocative, or advertising messages, insults, profanity, or obscene images;
- they shall not contain Nazi attributes or symbols, or attributes or symbols of extremist organizations, or attributes or symbols that are confusingly similar to them;
- they shall not insult the honor and dignity of the participants of the Match and the Championship, the audience and/or the League, the Host Club, or the Guest Club;
- they shall not be items that cannot be used and/or stored in accordance with the legislation of the Russian Federation (for Matches held on the territory of the Russian Federation) or in accordance with the legislation of Foreign Club countries (for Matches held on the territory of Foreign Club countries);
- they shall have a translation into Russian of the words and/or expressions contained in the means of support in the state languages of the republics of the Russian Federation and/or foreign languages, which is certified by the Host Club and presented by the spectator to the person authorized by the Host Club at the entrance to the venue of the Match (for the Matches taking place on the territory of the Russian Federation);
- shall have a translation into the state language of the country of the Foreign Host Club of the words and/or expressions in foreign languages contained in the means of support, which is certified by the Foreign Host Club and presented by the spectator to the person authorized by the Host Club at the entrance to the venue of the Match (for the Matches taking place outside the territory of the Russian Federation).

The content of images and text on the means of support should only be aimed at supporting own Club. The means of support specified in this subclause, which do not require prior approval from the Host Club, shall be placed in places where they will not interfere with the viewing of the Match by other spectators.

34.11.2.

Fans of the Host Club and/or fans of the Guest Club in order to support their team at Matches in the sectors for active support, subject to the appointment of responsible persons from among the fans who will be present at such a Match, for each unit of the following means of support are allowed to carry and use the following means of support:

- drums with a diameter of up to 60 cm and a height of up to 40 cm, without a bottom or with a transparent bottom;
- wind instruments for extracting sounds, namely pipes and horns, sound level – up to 90 dB;
- flags up to 2 meters x 1.5 meters in size on plastic hollow poles that do not exceed 1.5 meters in length and 2.5 centimeters in diameter (the use of flags with other poles is prohibited);
- banners up to 2 meters x 1.5 meters in size. Banner shall be made of non-flammable materials (be impregnated with special compounds) and have fire safety certificates;
- banner cloths of any size. Banner cloths shall be made of non-flammable materials (be impregnated with special compounds) and have fire safety certificates;
- flag cloths of any size. Flag cloths shall be made of non-flammable materials (be impregnated with special compounds) and have fire safety certificates.

Additionally, the means of support that are supposed to be used in the sector for active support:



VTB UNITED LEAGUE REGULATIONS

SEASON 2020-2021

- shall have a translation into Russian of the words and/or expressions contained in the means of support in the official languages of the republics of the Russian Federation and/or foreign languages, which is certified by the Host Club (for Matches held on the territory of the Russian Federation);
- shall have a translation into the official language of the Foreign Host Country of the words and/or expressions contained in the means of support in foreign languages, which is certified by the Foreign Host Club (for Matches held outside the territory of the Russian Federation);
- if they contain abbreviations and combinations of numbers, they shall have a written explanation of the meaning of abbreviations and combinations of numbers;
- the content of images and text on the means of support shall be aimed only at supporting own Club, shall not contain political, extremist, provocative or advertising inscriptions, insults, profanity or obscene images; shall not contain Nazi attributes or symbols or attributes or symbols of extremist organizations, as well as attributes or symbols similar to them to the extent of confusion; shall not aim to insult the honor and dignity of participants of the Match and the Championship, spectators and/or the League, the Host Club, the Visitor Club;
- means of support shall be placed in places where they will not interfere with other spectators watching the Match. Their placement in a sports facility is determined by the Host Club responsible for security, in agreement with a representative of the Internal Affairs Ministry and a representative of the Ministry of Emergency Situations at the Match (for Russian clubs) and with representatives of law enforcement or security agencies (for Foreign Clubs).

Carrying and using the means of support specified in this subclause 34.11.2. of the Regulations, are allowed only if the fans of the Host Club or the fans of the Guest Club have previously agreed with the Host Club.

Approval is carried out no later than one (1) calendar day before the day of the Match, where it is intended to use such means of support, on the basis of a written application.

The written application shall specify the representatives of fans responsible for using each support unit during the Match, whose identities shall be verified, and who shall be present at the Match.

Responsible persons from among the fans specified in the written application shall, 1.5 hours before the start of the Match, present the means of support specified in the written application for compliance with the requirements to a person authorized by the Host Club at the entrance to the Match venue.

The means of support that do not meet the requirements of this Regulation are not subject to approval. The Host Club shall notify the applicant of the decision in writing.

The number and locations of means of support agreed in the manner specified in this subclause shall be determined by the Host Club.

34.12 Other obligations

34.12.1 To provide the necessary equipment and personnel for cleaning the playing court during the Game in the number of at least two (2) people. Staff shall be at a distance no closer than two (2) meters from the playing court and be located to the right or left of the stands of both basketball backboards, and not obstruct the view for cameras and Referees.

For violation, a fine in the amount of one hundred thousand (100,000) RUB is imposed on the Host Club for each.

34.12.2 Meet the requirements for ensuring the security of the Match (Article 39 of these Regulations).

34.12.3 The Host Club shall provide copies of the video recording of the Match on memory sticks (USB 3.0), received earlier from the relevant persons, to the members of the referee team, the



VTB UNITED LEAGUE REGULATIONS

SEASON 2020-2021

Commissioner, the Official Delegate-Inspector and the Guest Club no later than thirty (30) minutes after the end of the Match.

ARTICLE 35 OBLIGATIONS OF THE GUEST CLUB IN RELATION TO MATCH PARTICIPATION

- 35.1** The Guest Club takes on the following obligations of the Guest Club team:
- travel expenses to the venue of the Match and back;
 - accommodation and meals of Players, Coaches, Assistant Coaches and Team Followers.
- 35.2** The Guest Club shall notify the Host club of the date, time and place of arrival, the number of the delegation, to coordinate the training time not later than seven (7) calendar days prior to arrival.
- 35.3** The Guest Club shall submit a written application to the Host Club not later than fourteen (14) calendar days prior to the date of the Game to purchase a specified number of tickets for fans of the Guest Club, in accordance with clause 34.7 of these Regulations. During a Play-off series, application shall be submitted not later than on the next day after the previous Match of the series. In case of violation of the established terms, the Guest Club may be denied the right to purchase the claimed number of tickets.
- 35.4** The Guest Club takes responsibility for fulfillment of the following requirements during the Match by their supporters who were provided tickets in compliance with clause 35.3 of art. 35 of these Regulations by the Guest Club:
1. Use of horns, drums and pipes by the fans during the Match is allowed only at the tribunes, but no closer than the tenth (10th) row (if there are less than 10 rows in a sport facility, then it is allowed at the last row). Use of horns, drums and pipes in other places of a sport facility is prohibited. The sound volume of musical instruments shall adapt to the dimensions of a playing court and spectators tribunes and the noise created by spectators to a maximum sound pressure level of ninety (90) decibels, measured at a distance of one (1) meter from the sound source.
 2. It is forbidden to use megaphones and other portable sound amplifying equipment during Matches.
 3. It is forbidden to use whistles disturbing Players during Matches (except for Referees)
- For violation, a fine in the amount of one hundred thousand (100,000) RUB is imposed on the Guest Club for each violation of subclauses 1–3 of clause 35.4 of Art. 35 of these Regulations.**
- 35.5** The Guest Club has the right to provide the Host Club with a memory stick (USB 3.0) for copying the video recording of the Match no later than thirty (30) minutes before the start of the Match.

ARTICLE 36 MEDICAL SUPPORT REQUIREMENTS

- 36.1** At each match of the Championship, a medical team shall work, which is formed by the Host Club and consists of a permanent staff and attracted members.
- Permanent staff is formed by the Host Club for each Championship Match and consists of the Chief Physician of the competition, a sports medicine doctor and a nurse from the medical center of a sports facility, a physician of the Host Club.



VTB UNITED LEAGUE REGULATIONS

SEASON 2020-2021

Also, at each Championship Match, the medical team shall have engaged members: two (2) mobile ambulance teams (one of which shall be resuscitation team) and the Guest Club doctor.

36.2

The medical team is responsible for providing medical support in preparation for the Match, during the Match and after the Match in the period specified in paragraph 36.3. of these Regulations.

The Chief Physician of the competition is responsible for organizing and coordinating the work of the medical team.

Medical team during the preparation for the Match:

- determines the ways of medical evacuation from the Match venues and spectator tribunes;
- conducts joint exercises with the medical staff of mobile emergency medical teams to evacuate injured and sick people to medical institutions, as well as interaction in cases of natural, man-made and terrorist emergencies;
- if there are conditions that prevent conducting the Match (for example, it is impossible to organize an evacuation to a medical facility or there are difficulties in providing effective medical care at the medical point of a sports facility), the Chief Physician of the competition shall inform the Match Commissioner and the Club management before the Match starts;
- in case of detection of medical, sanitary and epidemiological risks to the life and health of the participants of the Match and the spectators, the Chief Physician of the competition can recommend in writing to the Match Commissioner the cancellation or postponement of the Match.

During the Match, the medical team together with the field ambulance teams provides medical assistance to the Players, other participants of the Match and spectators.

36.3

Representatives of the medical team specified in clause 36.1 of these Regulations shall be present at the sports facility from the moment when the spectators start to enter the territory of the sports facility, but not less than sixty (60) minutes before the start of the Match, during the entire time of the Match, as well as within thirty (30) minutes after the end of the Match.

Representatives of the medical team shall be dressed in the uniform of a medical worker and be in close proximity to the playing court. They shall be presented to the Guest Club before the start of the Match.

If there are no doctors in the medical team during the specified period, the Host Club is fined one hundred thousand (100,000) Rubles.

In case of absence of doctors of the medical team within fifteen (15) minutes after the start time of the Match, the Host Club is fined two hundred thousand (200,000) RUB and loses the game by "FORFEIT".

36.4

To provide emergency medical care to Players, other participants and spectators during the Match, the Host Club shall ensure the presence at the entrance to the sports facility of two (2) ambulances with two (2) mobile ambulance teams (with the necessary medical equipment: cardiac equipment, resuscitation equipment), as well as the presence of such an ambulance team in the immediate vicinity of the playing field from the moment the spectators begin to enter the territory of the sports facility, but not less than sixty (60) minutes before the start of the Match, during the entire time of the Match, as well as within thirty (30) minutes after the end of the Match.

If there are no ambulances with an ambulance team during the specified period, the Host Club is fined two hundred thousand (200,000) RUB.

If there are no ambulances with an ambulance team within fifteen (15) minutes after the start time of the Match, the Host Club is fined three hundred thousand (300,000) RUB and loses the game by "FORFEIT".

36.5

In order to provide first aid during team training, the Host Club shall ensure the operation of the first aid point (medical point) in the sports facility. It is not recommended to conduct training events without a working medical center in a sports facility.



VTB UNITED LEAGUE REGULATIONS

SEASON 2020-2021

- 36.6** The organization of medical support in Russian Clubs shall be carried out in accordance with the license for medical activities, obtained in accordance with the requirements of the legislation of the Russian Federation, by the Club or the person/organization providing medical support to the Club. At the same time, it is recommended to obtain a license for medical activities in physical therapy and sports medicine.
- Licensing of medical activities of Foreign Clubs shall be carried out in accordance with the national legislation of such clubs in the field of health.
- 36.7** Medical support of the Club is provided by the Club. The Club shall have:
- at least one (1) doctor with the specialty "Medical business". Club doctors are required to have a valid certificate or certificate of accreditation for the specialty "Physical Therapy and Sports Medicine»;
 - at least one (1) Massage Therapist. Massage Therapists of the Club shall have a diploma of secondary professional medical education and a valid certificate or certificate of accreditation for the specialty "Medical Massage" or "Physical Therapy".
- 36.8** Duties of the Club's doctor:
- organize mandatory in-depth medical examinations for the Club's Players at least one (1) time in six (6) months, and monitor the passage of preliminary and periodic medical examinations by the Club's Players;
 - conduct ongoing medical monitoring of the health of the Club's Players and their tolerance of training and competitive loads;
 - promote periodic, including pre-match, testing of Players and other Club members for the new coronavirus infection (COVID-19) in order to prevent the spread of such infection, taking into account the recommendations on the procedure of holding sanitary and anti-epidemic (preventive) measures developed by the Directorate of the Championship of the VTB United League and approved by the Federal Service for Supervision of Consumer Protection and Welfare in preparation and holding of the training process and Championship matches by the Clubs (hereinafter - Recommendations);
 - immediately inform the Club management of changes in the health status of the Club's Players that may threaten their lives, including the detection of infectious diseases;
 - carry out, including taking into account the recommendations of health authorities, the necessary preventive and anti-epidemic measures in case of detection of a patient with a suspected infectious disease among the Club's Players and employees;
 - organize medical and diagnostic events for the Players and employees of the Club in a planned manner when there are appropriate changes in the state of health;
 - perform medical admission of Players to Matches;
 - attend all trainings and Matches, to carry out professional activities during practices and Matches with medicines and medical equipment necessary for providing medical care in case of emergency conditions in accordance with the requirements for completing a sports medicine physician's kit specified in Appendix No. 6 of Order of the Ministry of Health of the Russian Federation of March 1, 2016 No. 134n (for Russian Clubs) and the requirements of the legislation of the country of the Foreign Club (for Foreign Clubs);
 - provide emergency and urgent medical assistance to the Match participants who need such assistance;
 - when providing medical care, use only medicines and methods officially registered on the territory of the Russian Federation (with the exception of Foreign Clubs);
 - do not use any means or methods prohibited by anti-doping legislation;



VTB UNITED LEAGUE REGULATIONS

SEASON 2020-2021

- inform Players and other employees of the Club about the main provisions of the antidoping rules and their changes;
- if it is necessary to use substances and methods included in the WADA prohibited list for life reasons, assist the Club's Players to make a request for the therapeutic use of substances and/or methods prohibited in sport in accordance with the rules of the world Anti-Doping Agency (WADA) and promptly inform the Club's management;
- maintain the necessary medical documentation when applying for medical assistance from the Club's Players, and observe the necessary confidentiality principles.

In case of the Club's violation of the Recommendations specified in this paragraph, including in absence of testing of the Players, other persons of the Club for a new coronavirus infection (COVID-19) a fine of 200,000 (two hundred thousand) rubles shall be imposed on the Club for each untested person.

In case if the Club conceals information on the positive test of the Players, other persons of the Club for COVID-19, a fine of 500,000 (five hundred thousand) rubles shall be imposed on the Club for each fact of concealment. If the Club's concealment of such information results in mass coronavirus infection (COVID-19) of the Players, other persons of the Club and/or participants of the Championship, a fine of 1,000,000 (One million) rubles shall be imposed on the Club and the respective information shall be transferred to the authorized bodies for the appropriate decision.

- 36.9** The Club's doctor and massage therapist shall be entered in the Team's Passport and in the Technical Entry for each Match. The Club's doctor has the right to enter the playing area at any time without the permission of the referees, if a team Player is injured and, in the opinion of the Club's doctor, needs medical assistance.

ARTICLE 37 VIDEO REPLAY SYSTEM FOR REFEREES DURING THE GAMES

- 37.1** At all Championship games, the Host Club is required to provide equipment of the video replay system for Referees in working condition and in accordance with technical requirements of these Regulations that shall be provided for use by Referees in situations provided for in FIBA Official Basketball Rules.

For violation, a fine in the amount of five hundred thousand (500,000) RUB is imposed on the Host Club.

- 37.2** Video replay equipment for Referees should be placed on the Referees table (from left or right edge of the table). Referees should have clear access to the video replay equipment during the Match.

- 37.3** Not later than one (1) hour before the Game starts, the Referee and the Game Commissioner, in conjunction with the Operator of the video replay system for Referees, verify the availability of a video replay system for Referees, as well as its operability in accordance with the technical requirements specified in these Regulations. Based on the results of the audit, subject to the conformity of the video replay system for Referees to these Regulation, the Referee is authorized to approve a system of video replay for Referees.

- 37.4** Club representatives, Mass Media, spectators or other people except for Referees and Commissioner should not be located in the area of video replay system for Referees. Match Commissioner is authorized to demand security service of the Host Club to move away all unauthorized persons when video reply system is in operation.

- 37.5** Use of video replay system for Referees should be organized by its Operator, for Referees to watch required episode immediately after the decision taken by Chief Referee.



VTB UNITED LEAGUE REGULATIONS

SEASON 2020-2021

37.6 Use of video replay system for Referees for watching required episode of the match shall be performed only by Chief Referee and Match Judges if necessary, and then Chief Referee takes final decision.

37.7 Operator of video replay system should have sufficient knowledge of English to communicate with Referees.

For violation of cl. 37.2–37.7 of art. 37 of these Regulations, a fine in the amount of five hundred thousand (500,000) RUB is imposed on the Host Club for each clause separately.

37.8 **Technical requirements to video replaying system for Referees.**

Video replay system for Referees shall correspond to the following requirements:

- Monitor with a size of at least 21 inch and control panel with the ability to show images from at least 4 cameras video shooting the Match simultaneously and separately on the screen. Picture from each of the cameras has to display main time and shot clock.
- Video replay system for Referees shall possess fast-forwarding functions (forward, backward) for searching required game moment, slow-motion rewind and frame-by-frame viewing. It is also necessary to envisage the possibility to provide a record of a particular game moment (or the whole game) at the request of the Chief Referee.

A fine in the amount of two hundred thousand (200,000) RUB will be imposed on the Host Club for violation.

ARTICLE 38 CLUBS RESPONSIBILITY IN RELATION TO MATCHES

38.1 Clubs participating in the Championship are liable in the event of violation of these Regulations under procedure established by these Regulations and the national legislation of the country of the Championship Participant.

38.2 The Club and the League should use all their opportunities to coordinate any issues.

38.3 Clubs are responsible for medical eligibility of their players to participation in training and Matches of the Championship and liable for any accidents that may happen to players during training and Matches of the Championship (injuries and other accidents, even death).

38.4 Clubs are responsible for the behavior of the Players of their team, Official and the Club's Team Followers and any other person performing their functional duties on the Match on behalf of the Club. Official and the Club's Team Followers have no right to interfere with the actions of the Referees, the Commissioner and the Official Delegate of the Match.

38.5 Clubs are responsible for the behavior of their "spectators" and "fans" before, during and after the Match. By "their fans" for the Guest Club, we mean fans who stay during the Match in the active support sector of the Guest Club who provided them with tickets in accordance with clause 35.3 of Art. 35 of these Regulations. All other spectators and supporters present at the stadium are considered "spectators and supporters" of the Host Club.

ARTICLE 39 SAFETY DURING THE GAME

39.1 The Host Club takes responsibility for providing safety during training and Matches of the Championship in relation to their participants (Referees, Commissioner, Table Officials, representatives of the League, Players, Coaches, Team Followers and other persons) as well as



VTB UNITED LEAGUE REGULATIONS

SEASON 2020-2021

public security measures in the area of conduct of the Match (including territory surrounding sport facility) before, during and after each home Match of the Championship.

39.2

The Host Club shall:

- notify respective territorial body of the Ministry of Interior of the Russian Federation on the municipal level on the venue, date and period of competition in accordance with the procedure stated by Federal law “On Physical Culture and Sport in the Russian Federation” (for Russian Clubs);
- organize interaction with state authorities of the Russian Federation, state authorities of subjects of the Russian Federation and local self-government bodies in solving issues of ensuring public order and public safety during home matches of the Championship (for Russian clubs);
- organize interaction with local executive authorities and law enforcement bodies or security bodies aimed at provision of measures of public order and security in relation to Matches of the Championship (for Foreign Clubs);
- develop and approve a plan of measures to ensure public order and public safety during the Championship Matches no later than ten (10) days before the start of the Championship;
- approve the act on the readiness of the venue for home matches of the Championship one day before their start (the form of the act is provided by the League);
- inspect sport facility, venue of home Matches together with the owner of this sport facility at least three (3) hours prior to the start of the home Championship Match, prepare and approve respective certificate not later than spectators start entering the venue (the form of certificate is provided by the League);
- organize access control and internal security policy at the venue of home Championship Match during its holding;
- secure storage of objects prohibited for carrying in the spaces or specially prepared premises;
- monitor activities of controllers;
- fulfill access control, checking spectators’ entry tickets or documents, substituting them, including use of technical means;
- implement fire-protection measures;
- inform spectators and participants of competitions on requirement to obey by the rules of behavior for spectators used in the sport facility taking into consideration specifics foreseen by these Regulations;
- monitor compliance by spectators with the rules of behavior of spectators operating in a sports facility, taking into account the features provided for by these Regulations, creating, including for these purposes, a security headquarters, involving law enforcement officers, private security companies, supervisors, etc.;
- provide spectators and participants of the Championship Matches with first medical aid if required and organize service of the ambulance;
- in agreement with the Match Commissioner, suspend home Matches in the Championship before the elimination of violations hereof in the case of group violations of public order or threats to the lives and health of citizens; by agreement with the League, stop home matches of the Championship, if the violations specified in this paragraph (group violation of public order, threat to life and health of citizens) are not fixed, and if there is information about the possibility of a terrorist act;
- inform spectators and participants of home Matches of the Championship on termination of home Matches and on the procedures of actions under threat of emergency situation or when it occurred, organize their evacuation in case of threat or occurrence of emergency situation.



VTB UNITED LEAGUE REGULATIONS

SEASON 2020-2021

- 39.3** To ensure security measures of home Games of the Championship, the Host Club shall establish security headquarters which includes:
- representative of the Host Club – chief of security headquarters;
 - representative of the Ministry of Internal Affairs and the Emergencies Ministry (for Russian Clubs);
 - representative of security institution;
 - representative of controlling service;
 - other representatives of law enforcement agencies or security agencies (for Foreign Clubs).
- 39.4** Each Club during the procedure of licensing (Article 8 of the Regulations, Annex 3 to the Regulations) shall provide the League with:
- safety certificate of sports facility, Instruction on public peacekeeping and safety on the sports facility during Championship Matches and Plan of measures to ensure public order and public safety during the Championship Matches (for Russian Clubs).
 - sports facility security passport, rules/instructions for ensuring public order and public safety at the sports facility or other documents on security during the Championship Matches in accordance with the requirements of the legislation of the country of the Foreign Club (for Foreign Clubs).
- 39.5** Action plan for ensuring security of Game/instruction on ensuring public order and public safety (for Russian clubs) or other safety documents during Championship Matches in accordance with the requirements of the national laws (for Foreign Clubs) shall include:
- security of Referees, a Commissioner, an Official Delegated Inspector, representatives of the League, Table Officials, Players, Trainers, Officials and Team Followers from the moment they arrive on the territory of the sports facility where the Game is held and until their departure from the territory of the sports facility, including the places of workouts, games, press conferences;
 - organization of access to a sports facility, including, according to officially issued documents of the established sample (entrance tickets or documents replacing them, including accreditation);
 - organization of traffic, parking and security;
 - inspection of the sports facilities by the security staff members two hours before the Game starts, with the purpose of identifying foreign objects that could lead to the failure of the game or to create a threat to the safety of the Game participants and spectators;
 - arrangement of security desks in the necessary places two (2) hours before the Game starts;
 - measures to ensure public order in the area of the Game before, during and at least thirty (30) minutes after the Match;
 - medical aid station.
- 39.6** Not later than one (1) hour after the end of the Game, the Club fills in and signs the Certificate on the implementation of security measures of the Game in the form in accordance with Annex No. 12 to these Regulations. This Certificate shall be submitted to the League through a Commissioner of the Game.
- 39.7** **The Host Club shall provide:**
- safety of Players, Coaches, Referees, Commissioner, an Official Delegated Inspector, representatives of the League, Table Officials, Officials and Team Followers from the moment they arrive on the territory of sports facility and until their departure from the



VTB UNITED LEAGUE REGULATIONS

SEASON 2020-2021

- territory of the sports facility as well as safekeeping of sport equipment and other property of those persons staying in sport facility and at surrounding territory;
- interaction with local traffic police bodies or other authorities in accordance with the national laws of the country of the Club, providing traffic organization for motor vehicles, concerning the organization of traffic, the parking and security;
 - proper control of the admission of spectators to the tribunes of the sports facility according to officially produced documents of the established type (tickets, season tickets, accreditation, invitations, etc.), which excludes the possibility of penetration into the sports facility on the day of the Game of persons using documents bearing obvious signs of forgery;
 - proper control of the admission of spectators to the tribunes of the sports facility, which prohibits the transfer of objects and substances prohibited for use in sports facility (alcohol, weapons, pyrotechnic products, etc.) to the sports facilities;
 - proper control over observance by the spectators of the rules of conduct in the sports facility in order to prevent and suppress incidents and disorders, throwing of objects and substances on the playing court, at spectators, Players, Coaches, Referees, Club representatives and other negative manifestations;
 - safety of post-game press conferences and its participants, excluding the possibility of their attendance by persons who do not have accreditation of a standard form;
 - security and access control to mixed zones intended for communication of accredited media representatives with Players and Coaches, as well as for communication of accredited media representatives with Players and Coaches in team changing rooms at the end of the Championship Game;
 - the necessary number of technical facilities and specialists trained in methods of operative clearance of pyrotechnic devices, actions in emergency situations (fire, smoke, etc.);
 - security and access control at the unit of doping control. The post is only arranged if a doping control procedure is being carried out during the Game;
 - prohibition of access to the sports facility where the Game takes place for all spectators who enter with alcoholic beverages, weapons, as well as items that can be used in this capacity, such as flares or similar pyrotechnic products; for viewers who are under the influence of alcohol, psychotropic drugs, stimulants or the like.

A fine in the amount of five hundred thousand (500,000) RUB will be imposed on the Club in case of violation.

39.8

Secured facilities

39.8.1

The mandatory secured facilities:

1. Match zone in general (sport facility and its surrounding territory);
2. Spectators' tribunes;
3. Dressing rooms of Players and Coaches;
4. Dressing rooms of Referees, Commissioner and Official Delegate-Inspector;
5. Dressing rooms of Table Officials;
6. Area of teams' benches at the playing court (at least two (2) guards for each team one (1) hour before the Match starts and until they get on the bus to go to the hotel);
7. Media areas, press-conferences rooms;
8. Doping control station (if there is doping control procedure implemented during the Match);
9. Tribunes for honorary guests;



VTB UNITED LEAGUE REGULATIONS

SEASON 2020-2021

10. Referees, the Commissioner, the Official Delegate- Inspector, Table Officials at the playing court (at least two (2) guards starting one (1) hour before the Match starts and until they get on transport to go to the hotel);

A fine of three hundred thousand (300,000) RUB shall be imposed on the Host Club for violation of these requirements. Any violations shall also be resolved.

If the violation resulted in the occurrence of an incident, a fine in the amount of 500,000 (five hundred thousand) RUB is imposed on the Club.

39.8.2 Admission of other persons to Referees', Commissioner's and Official Delegate/Inspector's dressing and shower rooms is strictly prohibited. Host Club takes the responsibility for fulfilling this rule.

In case of violation a fine of three hundred thousand (300,000) RUB shall be imposed on the Host Club. If violation leads to an incident, the Club will be fined in the amount of five hundred thousand (500,000) RUB.

39.9 Chief of security headquarters shall be introduced to the Commissioner, the Official Delegate Inspector, Club representatives upon arrival at sport facility.

39.10 The Host Club shall ensure that the following requirements are met:

39.10.1 Spectators have the right to:

1. If they have entrance tickets, season tickets, invitations and documents replacing them, enter the sports facility before and during the Match, occupy an individual spectator seat specified in the entrance ticket or in the document replacing it. The start time of the passage to the sports facility is determined by the decision of the Host Club. The number of passes of the spectator to the sports facility during one Match, if there is an entrance ticket, season ticket, invitations and documents replacing them, is determined by the Host Club;
2. Use all services provided during the Match in the sports facility and in the surrounding area;
3. Bring personal items to the tribunes and use them if they are not prohibited by these Regulations, as well as means of support that meets the requirements of these Regulations.

39.10.2 It is prohibited at a sports facility or the territory adjacent to it:

1. Sell and drink alcoholic beverages;
2. Smoke in areas not designated for it;
3. Use flags with a flagpole (flags with a hollow flagpole are allowed);
4. throw any objects on the playing court;
5. Insult or threaten Referees, Commissioner, Official Delegate-Inspector, Referees-Secretaries, Players, Coaches, Team Followers or spectators (in verbal or other form);
6. Sell beverages in glass and iron containers. The sale of beverages is allowed only in plastic containers with a volume of no more than 0.5 liters. Access to the spectator seats with drinks is only possible when using plastic or paper cups;
7. Be in a state of alcoholic and/or narcotic intoxication.

The Host Club is responsible for compliance with the provisions of clause 39.10.2. of these Regulations.

For violation, the Host Club shall be fined in the amount of five hundred thousand (500,000) RUB and/or be subject to additional punishment, which is determined by a special decision of the Directorate.

39.10.3 It is prohibited for spectators in the venues of the Championship Matches:

1. Be in a state of intoxication that offends human dignity and public morality;
2. Perform actions that endanger their own safety, life, health, as well as the safety, life, health of other persons located at the venue of matches or on the territory adjacent to it;
3. Throw objects in the direction of other spectators, participants of the Championship and other persons located at the venue of the championship Matches or on the territory adjacent to it;



VTB UNITED LEAGUE REGULATIONS

SEASON 2020-2021

4. Offend other persons (including using banners, posters, flags and other means of visual propaganda) and perform other actions (including using obscene, offensive, discrediting gestures) that discredit the honor, dignity or business reputation or aimed at inciting hatred or hostility, as well as to humiliate the dignity of a person or group of persons on the grounds of gender, race, nationality, language, origin, attitude to religion;
5. Wear and display and use signs, attributes and other symbols of a fascist or racist nature, as well as use signs, attributes and symbols similar to them to the extent of confusion; display attributes or symbols of extremist organizations; use words and expressions, as well as gestures of a fascist or racist nature;
6. Hide their faces, including using masks (except for the use of medical and other protective face masks for the purpose of preventing and excluding the spread of viral and other infections, if their use is permitted and/or recommended by the Directorate, taking into account the recommendations of Federal or local authorities of the Russian Federation and/or authorities of countries of Foreign Clubs).
7. Violate public morals and norms of behavior by exposing private parts of the body while in the venues of the Championship Matches;
8. Enter the venue of the Championship Matches or the territory adjacent to it, without an entrance ticket or a document replacing it, as well as areas not indicated in the entrance ticket or in the document replacing it (the playing court and areas around it, changing rooms of teams, Referees, other office and technical premises, areas for honored guests, places intended for housing representatives of the media), access to which is restricted by the Host Club and the League and/or the owner of the sports facility;
9. Stay on staircases during the Championship Matches, obstruct traffic in areas of the Championship Match venues intended for evacuation, including in passageways, exits and entrances (main and reserve);
10. Put inscriptions and drawings on structures, buildings, facilities located in the venues of Championship Matches, as well as place foreign objects near them without the appropriate permission of the Host Club or owners of the sports facility;
11. Enter the venue of the Championship Matches with animals and birds, with the exception of guide dogs in muzzles;
12. Conduct public events that are not provided for in these Regulations and are not agreed with the Host Club and the League;
13. Bring to the venue of the Championship Matches and use:
 - weapons of any type, including self-defense, and ammunition, piercing or cutting objects, other items that can be used as weapons, explosives, poisonous, intoxicating and pungent-smelling substances, and radioactive materials;
 - flammable and pyrotechnic substances or articles (with the exception of matches, pocket lighters), including flares, firecrackers, gas cylinders and items (chemical materials) that can be used to make pyrotechnic products or fumes;
 - other substances, items, products, including homemade products, the use of which can lead to smoke, ignition;
 - devices and products, including self-made ones, that are not pyrotechnics, used for spreading and spraying various materials and substances (pneumatic flaps);
 - coloring materials;
 - musical instruments and wind instruments for extracting sounds (including vuvuzelas), with the exception of horns, pipes and drums, which can be used in sectors for active support in accordance with the procedure established by this Regulation;



VTB UNITED LEAGUE REGULATIONS

SEASON 2020-2021

- alcoholic beverages of any kind, narcotic and toxic substances or stimulants;
 - soft drinks in glass or tin containers, as well as in plastic containers with a volume of more than 0.5 liters. Access to the spectator seats with drinks is only possible when using plastic or paper cups;
 - propaganda materials of an extremist nature or containing Nazi attributes or symbols or attributes or symbols of extremist organizations;
 - technical means that can interfere with the conduct of Championship Matches or its participants (laser devices, flashlights), radio stations, sound amplification equipment;
 - bulky objects (any object whose dimensions in length, width, and height exceed 40 x 40 x 45 centimeters) that interfere with other viewers;
14. Carry out illegal trade (including the sale of entrance tickets or documents that replace them), distribute in any way products of a political, religious or racist nature (including posters, leaflets, booklets); 15. Smoke, use electronic cigarettes and other devices for smoking with smoke imitation in places where it is prohibited in a sports facility;
16. Ignite a fire;
17. Throw objects (substances) on the tribunes, the playing court and the space around it, as well as purposefully at spectators, Players, Coaches, Referees, representatives of Clubs, leagues, other Team Followers and Official persons, other individuals, or use objects (substances), the use of which intentionally or unintentionally may lead to the ingress of objects (substances) or their parts in the above-mentioned places or in the above-mentioned persons.

The Host Club is responsible for monitoring and ensuring that spectators comply with the provisions of this clause, except for the Guest Club's fans.

The Guest club is responsible for ensuring that the fans of the Guest Club comply with the provisions of this clause, who in accordance with clause 35.3. article 35 of these Regulations were provided by the Guest Club with entrance tickets.

For violation of this clause, the Host Club and/or the Guest Club shall be fined in the amount of five hundred thousand (500,000) RUB and/or be subject to additional punishment, which is determined by a special decision of the Directorate.

39.11 Guards providing security at sport facility can approach the playing court at a distance of less than two (2) meters or go directly to the playing court only at the request of the Referees.

In the event that spectators, Players, Coaches or Team Followers enter the playing court with the express intention to commit an Act of violence, security guards shall immediately intervene to protect Game participants and spectators.

39.12 Guards providing security at sport facility shall accompany a disqualified Player, Coach or Assistant Coach to the dressing room according to Commissioner's order when a Player, a Coach and Assistant Coach have violated Article 33 of these Regulations.

39.13 Sports facilities shall be equipped with a video surveillance system that allows identification of individuals during their stay in the competition venue with the ability to store information for at least one month in accordance with Resolution of the Government of the Russian Federation "On Approval of Safety Rules for Official Sports Events" of April 18, 2014 No. 353 (only for Russian Clubs).

39.14 Failure to meet Game security requirements

39.14.1 For non-compliance with the security requirements of the Match, which lead to the occurrence of the incident (fights, hooliganism, etc.), following the decision of the Directorate, the following sanctions may be imposed on the Host Club:

- **next game will be played without spectators;**
- **a fine from five hundred thousand (500,000) to one million (1,000,000) RUB;**



VTB UNITED LEAGUE REGULATIONS

SEASON 2020-2021

- **for a repeated violation – a fine in the amount of one million (1,000,000) to one million five hundred thousand (1,500,000) RUB;**

One or several sanctions can be imposed simultaneously by decision of the Directorate.



VTB UNITED LEAGUE REGULATIONS

SEASON 2020-2021

CHAPTER 7

REFEREEING

ARTICLE 40 GENERAL PROVISIONS

40.1 Referee, Commissioner, Table Officials and Official Delegate-Inspector

40.1.1 Refereeing of the Championship Games is carried out in accordance with FIBA Official Basketball Rules, as amended, clarified, supplemented and interpreted in individual articles of FIBA Official Basketball Rules, and these Regulations.

40.1.2 The League approves the list of Referees and Commissioners who can be appointed for Championship Matches. Referees and Commissioners must have a license/passport of a Referee/commissioner and qualification category of a basketball sport Referee (for Russian Referees).

40.1.3 The League approves the list of Table Officials for the season for each Club. Table Officials must have a qualification category of a basketball sport Referee and passport of a Table Official/Statistician issued by RBF (for Russian Clubs), license of a Table Official issued by National Federation (for Foreign Clubs).

40.1.4 The League can appoint Official Delegate-Inspector for certain Championship Matches.

40.2 Appointment of Referees, Commissioner and Table Officials

40.2.1 Each Game of the Championship is served by three (3) Referees, one (1) Commissioner and nine (9) Table officials.

40.2.2 The League appoints three (3) Referees and one (1) Commissioner for Matches of the Championship.

40.2.3 The Host Club appoints nine (9) Table officials from among those Table officials approved by the League.

40.2.4 Not later than sixty (60) minutes prior to the beginning of the Match, the Host Club shall provide the Commissioner of the Match with a list of Table officials specifying their passport/license number, signed by team representative of the Host Club at the Match.

40.2.5 In the event of a sudden injury or non-arrival of the third Referee, two Referees can officiate the Match.

40.2.6 For the purpose of unimpeded communication, Referees, Commissioners and Official Inspectors Delegates are required to have an e-mail address and access to the Internet.

40.2.7 The League shall inform Referees, Commissioners and Official Delegates-Inspectors about their appointment to the Matches. Referees, Commissioners and Official Delegates-Inspectors are required to confirm their appointments for Matches. Any Referee or Commissioner or Official Delegated Inspector, for unforeseen reasons, unable to accept an appointment, shall immediately notify the League in order to be replaced.

The inaccessibility of the Referee, Commissioner or Official Delegated Inspector shall be justified by a valid reason and he/she shall inform the League in advance.

40.2.8 Failure to comply with the above obligations may result in the removal of the Referee or the Commissioner or the Official Delegated Inspector from the appointments.

40.2.9 The League directly informs Referee, Commissioner and Official Delegated Inspector on their appointment for the Match, it shall be confidential and cannot be communicated to Clubs participating in the Game prior to their official notification by the League.



VTB UNITED LEAGUE REGULATIONS

SEASON 2020-2021

40.2.10 Appeals of clubs for replacement of Referees, Commissioner or Official Delegate- Inspector appointed for the Championship Matches as well as on appointment or non-appointment of Referees, Commissioner or Official Delegate-Inspector are not accepted or considered.

40.3 Arrival at the venue of the Match

40.3.1 Referees, Commissioner and the Official Delegate-Inspector shall arrive at the venue of the Match before or at least, before 10:00 am local time on the Match day if they travelled by train or auto transport.

40.3.2 In the event that Referees, Commissioner and an Official Delegate- Inspector travel to the venue of the Match on their own, they are obliged to report their arrival to the League office (date, time, mode of transport, flight number, etc.) no later than seventy-two (72) hours before the Match starts, having informed at the same time about the need to purchase a return ticket specifying the date and mode of transport.

40.3.3 Referees and Commissioner shall arrive at the sports facility, venue of the Championship Match, not later than one and a half hour (1.5) before Match starts.

40.4 Appearance of Referees, Commissioner, an Official Delegate-Inspector, Table officials

40.4.1 Referees, Commissioner and the Official Delegate-Inspector should be dressed in business suit (jacket, shirt and tie).

40.4.2 Equipment of Referees, Commissioner, and Table officials should meet requirements of Article 26 of these Regulations.

Rules of conduct of Referees, Commissioner and an Official Delegate- Inspector.

40.4.3 Each Referee, Commissioner and Official Delegate-Inspector shall comply with standards of conduct in public places and generally accepted moral standards on and off sport facility.

Communication of Referees, Commissioners and the Official Delegate-Inspector with representatives of the teams is permissible in the framework of ensuring the arrival, accommodation and departure, as well as during the Match, while this communication shall be respectful and concise. Unnecessary familiarity is strictly forbidden.

40.4.4 Referees, Commissioner and the Official Delegate-Inspector shall have memory drive (USB 3.0) and provide it to the Host Club for copying of Match video-recording not later than thirty (30) minutes before the Match starts.

40.4.5 Referees, Commissioner and Official Delegated Inspector are never allowed to accept cash and valuable gifts from persons affiliated with Clubs. Referees, Commissioner and Official Delegate-Inspector shall immediately advise the League on any such cases.

40.5 Responsibility of Referees, Commissioner and an Official Delegate-Inspector.

40.5.1 In the event of improper performance by the Referees, Commissioners or Official Delegates-inspectors of their duties entrusted to them by these Regulations, before, during and/or after the Game, the Directorate has the right to decide on the application of sanctions to them:

- Warning;
- Fine in the amount of 100% of remuneration of a Referee, Commissioner or Official Delegate-Inspector for this Match;
- Temporary suspension from appointment to the Championship Matches for a period of up to 3 years;
- Life disqualification.



VTB UNITED LEAGUE REGULATIONS

SEASON 2020-2021

ARTICLE 41 OBLIGATIONS OF REFEREES

- 41.1** Referees of the Game shall perform their duties in accordance with FIBA Official Basketball Rules including but not limited to:
- checking the operability and compliance of the playing court and technical equipment with the requirements of FIBA Official Basketball Rules, FIBA Official Basketball Rules – Basketball Equipment and these Regulations;
 - checking the availability and performance of the necessary equipment for viewing video replay in situations stipulated by FIBA Official Basketball Rules;
 - to use devices that automatically stop time at the whistle during the Match and check their performance;
 - implement measures of spotting people before and during the Match in the zone of the team bench according to the Technical entry for the Match;
 - settlement of all disputable moments arising during the Game.
- 41.2** Upon arrival at the venue of the Game, the Referees shall immediately be introduced to the Commissioner.
- 41.3** All Referees shall appear on the court twenty (20) minutes before the Match begins. Referees shall meet with Table officials and stay on the opposite side of the Referees table so that to have a possibility to watch warming-up teams Referees warming – up is allowed before the Match, however, one Referee should watch warming-up teams.
- 41.4** In Commissioner’s absence, the Referee shall perform his/her duties.

ARTICLE 42 COMMISSIONER OBLIGATIONS

- 42.1** The Commissioner is a representative of the League at the Match.
- 42.2** The Commissioner shall assist Clubs in the implementation of the requirements of these Regulations.
- 42.3** The Commissioner appointed to the Championship Matches is acting on behalf of the League. He/she shall have the necessary knowledge of FIBA Official Basketball Rules, FIBA Official Basketball Rules – Basketball Equipment and these Regulations in order to fulfill his/her duties. During the Match, the Commissioner shall sit at the Referees’ table between the timekeeper and the secretary.
- 42.4** Main obligations of the Commissioner are as follows:
- Control of the presence of all Table Officials before and during the Match;
 - Mandatory check of the presence of passports/licenses of Table Officials in accordance with their duties;
 - Control and coordination of the work of Table Officials;
 - Assist and advise Referees on FIBA Official Basketball Rules, FIBA Official Basketball Rules– Basketball Equipment and these Regulations before, during and after the Match;
 - Filling in the Commissioner's report and report on watching video-recording of the Match and marketing report;
 - Control of compliance with requirements of FIBA Official Basketball Rules, FIBA Official Basketball Rules– Basketball Equipment and these Regulations and decisions of the Directorate by all Match participants and spectators;



VTB UNITED LEAGUE REGULATIONS

SEASON 2020-2021

- Immediately notify the League on violations, incidents and Referees' reports;
- Immediately notify the League on protests lodged by one of the teams.

42.5 Commissioner shall ensure compliance with the requirements of the Regulation regarding location of persons entered in the Technical entry for the Match in the zone of team bench.

42.6 Arrival

42.6.1 Upon arrival in the venue of the Championship Match the Commissioner shall receive information from the representative of the Host Club about the arrival and accommodation of the Guest Club, on conduct of training and security of the Match participants.

42.6.2 If the Guest Club has reasonable claims about non-compliance with the Regulations by the Host Club, the Commissioner, together with the Host Club, shall take measures to eliminate violations and write accordingly in the Commissioner's report, and immediately inform the League.

42.7 **Before the Game.**

42.7.1 The Commissioner shall arrive at the sport facility at least one and a half (1.5) hour before the Match starts, where the Host Club has to introduce him to the Chief of security headquarters responsible for safety and security. Commissioner must receive from him all necessary information about security of the Match participants.

42.7.2 **Prior to the Match, the Commissioner shall:**

- control implementation of assigned duties by the Host Club and the Guest Club according to these Regulations;
- check relevance of the playing court and technical equipment with the requirements of FIBA Official Basketball Rules, FIBA Official Basketball Rules– Basketball Equipment and these Regulations;
- check availability of ambulance and medical personnel at the sport facility;
- control operation of first aid station at sport facility;
- check availability of necessary equipment and personnel for cleaning the playing court;
- check the availability of video replay equipment for Referees;
- check teams' passports duly issued by the League, licenses of Players and Club Team Followers against relevance of photographs to personalities included in the Technical entries for the Match by Clubs;
- check relevance of the list of Table Officials, submitted by the Host Club before the Match, with the list of the Club's Table Officials approved by the League and availability of all Table officials;
- check passports/licenses of Table Officials;
- verify the accuracy of Technical Entry for the Match including respective signatures of the Doctor and the Club's representative at the Match as well as relevance of Technical entry for the Match to requirements of these Regulations;
- check that no more than six (6) Players having licenses "N" and/or "Nn" (only one (1) Player with "Nn" license) were included in the Match Technical Entry;
- check whether official scoresheet was filled in correctly by the secretary;
- check implementation of marketing requirements of these Regulations by the Host Club by completing marketing report (according to the form submitted by the League).

42.7.3 The Commissioner shall check availability of text and video broadcasting of the Match during the Match and the final statistics after the Match ends on the League website.



VTB UNITED LEAGUE REGULATIONS

SEASON 2020-2021

- 42.7.4** The Commissioner shall reflect in his/her report any violations of the FIBA Official Basketball Rules, FIBA Official Basketball Rules– Basketball Equipment and these Regulations and take measures to eliminate them jointly with the Host Club.
- 42.7.5** If any difficulties occur in connection with the eligibility of Players and Club officials, the Commissioner shall immediately contact the League.
- 42.7.6** If a Player, a Coach or a Club Team follower was included in the Team Passport with the number of Player's, a Coach's or Club Team follower's license number, but does not carry the specified License, the Commissioner can allow him/her to participate in the Match provided other identification documents are presented.
- 42.7.7** The Commissioner together with Clubs is responsible for complying with the rules allowing players to participate in the Match.
- 42.7.8** The Commissioner shall check whether the restrictions imposed on the Clubs participating in the Game are fulfilled for failure to comply with the Regulations. He/she shall be informed about these restrictions in advance by the Directorate.
- 42.7.9** The Commissioner shall monitor the observance by the Match participants of the equipment provisions set forth in Chapter 4 of these Regulations before the Championship Match.
- 42.8** **During the Game.**
- 42.8.1** During the Game, the Commissioner coordinates and supervises work of Table Officials. The Commissioner supervises the qualitative functioning of Table officials. The Commissioner shall also monitor the strict observance of discipline by all table officials before a Game, during and after a Game. In cases of establishing gross violations, the Commissioner may require dismissal of any member of Table officials.
- 42.8.2** If situation occurs that could lead to a protest by one of the teams, the Commissioner shall consult Referees in order to avoid protest. This shall be done both during the time when the situation can be corrected in accordance with FIBA Official Basketball Rules, and in other moments of a Game, when a game clock is stopped.
- 42.8.3** If Referees are requested to provide assistance or provide the necessary information, the Commissioner shall do everything possible to help them. However, the final decision is made by the Chief Referee.
- 42.8.4** The Commissioner shall control implementation of clause 33.9 of Art. 33 of these Regulations and if necessary, invite security of the Host Club to accompany a disqualified Player, Coach or Assistant Coach to his/her team's dressing room;
- 42.8.5** The Commissioner shall check number of spectators attending the Match in statistical protocol and entitled to demand Table Officials to correct number of spectators in the statistical protocol based on his opinion on their realistic number.
- 42.9** **After the Match**
- 42.9.1** After the end of the Game, a Commissioner shall receive the first copy of scoresheet, statistical report, document on the implementation of security measures for the Match.
- 42.9.2** In case of acts of violence, aggressive behavior, unsportsmanlike conduct by Players and Coaches, Club Team followers, the Commissioner and/or Referees shall prepare a written report duly signed and send it by e-mail to the League within one (1) hour after the end of the Match.
- 42.9.3** After completing all the procedures necessary after the end of the Match, the Commissioner shall return Team passport, licenses of Players, Coaches and other Team Followers to representatives of the teams at the Match and hand over a copy of the scoresheet and a statistical report.
- 42.9.4** The Commissioner shall fill in the report on the form established by the League, indicating articles and clauses of these Regulations that have been violated, as well as the shortcomings in the work



VTB UNITED LEAGUE REGULATIONS

SEASON 2020-2021

of the table officials, if any. Violations of these Regulations are detailed in the "Comments" column on the last page of the "Commissioner's Report".

42.9.5 The Commissioner has to fill in the marketing report.

42.9.6 After the end of the Match, the Commissioner shall send the following documents to the League: **within one (1) hour after the end of the Match:**

- a copy of the official scoresheet, statistical report of the Match, report of the Commissioner and report of the Referee (if any), document on implementation of Match security measures, duly filled in and signed, list of Match Table officials, Clubs Technical entries. Documents shall be sent in pdf format (a low-quality photocopy is not accepted) to the e-mail address: referee@united-league.com.
- completed report of the marketing Commissioner with attached photos of the required materials. Documents shall be sent in pdf format (low-quality photocopies are not accepted) to the email address marketing@united-league.com;
- address of the team that filed the protest, and reports of the Officiating team (in case of protest filed by one of the teams). Documents shall be sent in *pdf format (a low-quality photocopy is not accepted) to the e-mail address: referee@united-league.com

within seventy-two (72) hours after the end of the Game

- the completed report on watching video-recording of the Match accompanied by assessment of Referees' performance at the Match (a copy of the report shall be sent by the Commissioner by email to referee@united-league.com, pitsilkas@united-league.com and to all Referees of this Match.

42.9.7 The Commissioner is responsible to monitor press conference organization after the Match.

42.9.8 In case of concealment of the facts of violation of the Rules, the Commissioner shall be suspended from servicing the Championship Matches for a term determined by the Directorate.

ARTICLE 43 OBLIGATIONS OF TABLE OFFICIALS

43.1 The Host Club shall appoint Table Officials for the Match from among those Table Officials approved by the League and take responsibility for their work.

43.2 The Host Club shall appoint nine (9) Table Officials to each Match of the Championship:

- secretary;
- assistant secretary (scoreboard operator);
- timekeeper;
- shot clock operator;
- speaker (announcer);
- operator-statistician;
- statistician 1;
- statistician 2;
- video replay operator for Referees.

43.3 Table Officials shall be qualified, competent and impartial. In case of poor work of Table Officials noted in the report of the Commissioner to the Host Club, a fine in the amount from **one hundred thousand (100,000) to two hundred thousand (200,000) RUB is imposed on the Host Club.**



VTB UNITED LEAGUE REGULATIONS

SEASON 2020-2021

- 43.4** Table Officials shall be at Referees' table and be ready to start performing their duties no later than one (1) hour before the Match starts. The Commissioner has the right to replace Table Officials who do not cope with their duties.
For violation, a fine in the amount of one hundred thousand (100,000) RUB is imposed on the Host Club.
- 43.5** Table Officials can leave their workplaces before, during and after the end of the Match only with the permission of the Commissioner.
- 43.6** During the Match, all Table Officials shall be dressed in the uniform form provided by the League.
For violation, a fine in the amount of one hundred thousand (100,000) RUB is imposed on the Host Club for each person.
- 43.7** The Host Club shall provide Table Officials with:
- Three (3) forms of the Match scoresheet provided by the League;
 - Two (2) control stopwatches;
 - Five (5) Players' foul pointers (Art. 7 of FIBA Official Basketball Rules – Basketball Equipment).
 - Two (2) Team foul pointers (Art. 8 of FIBA Official Basketball Rules – Basketball Equipment).
 - One (1) Possession pointer (arrow) (Art. 9 of FIBA Official Basketball Rules – Basketball Equipment).
 - Computer equipment with cable internet access for statistics of the Match, textual online broadcasting of the Match and printing of statistical reports (clause 47.2 of Art. 47 of these Regulations);
 - non-carbonated drinking water, nine (9) 0.5 L bottles per one (1) Match;
- For violation of clause 43.7 of Art. 43 of these Regulations, a fine in the amount of one hundred thousand (100,000) RUB is imposed on the Host Club for each of clauses 1–7 separately.**

ARTICLE 44 OBLIGATIONS OF THE OFFICIAL DELEGATED INSPECTOR

- 44.1** The official Delegate-Inspector of the Match is the official representative of the League during Matches who supervises performance by the Clubs, Referees, Commissioner and Table officials of their obligations under these Regulations before, during, and after the Game.
- 44.2** The Host Club shall secure a seat at spectators' tribune with a good view of the playing court for the official Delegate- Inspector. Official Delegate-Inspector shall not sit all the time at Referees table during the Match.

ARTICLE 45 EXPENSES RELATED TO OFFICIATING OF THE CHAMPIONSHIP.

- 45.1** The League shall meet the following expenses related to officiating of the Championship and/or reimburse such costs to Referees, the Commissioner and the Official Delegate-Inspector:
- Travel expenses:**
- The cost of booking and purchase of railway (ticket in the two-berth compartment) and air tickets (not more than for the ticket in the economy class saloon) to the Referees, the Commissioner and the Official Delegate-Inspector from the place of residence to the venue



VTB UNITED LEAGUE REGULATIONS

SEASON 2020-2021

of the Game and back (changes are possible by decision League for the purpose of optimizing the costs and/or route of travel), as well as the costs of issuing travel documents;

- Expenses for public transport, as well as Aeroexpress for transportation to the airport, to the railway station, if they are located outside the population center, at departure and transfer points, in the presence of supporting documents;
- Expenses for fuel and lubricants (if private vehicles are used by the Referees, the Commissioner and the official Delegate-Inspector) in the amount of actual expenses, if there are supporting documents;
- Expenses for payment for parking at airports (if private vehicles are used by the Referees, the Commissioner and the official Delegate-Inspector).

Accommodation and food expenses:

- accommodation expenses of Referees, the Commissioner and the Official Delegated Inspector in hotels (no less than three stars) in the venue of the Game and meals (three times) of the Referees, the Commissioner and the Official Delegate-Inspector;

Other expenses:

- expenses related to the issue of visas to the Referees, the Commissioner and the official Delegate-Inspector in the countries where the Game is held, the costs of compulsory medical insurance for traveling to the host country for games;
- other costs, previously agreed with the League and documented.

45.2 The League shall agree upon the route of travel, time of departure and flight number with every Referee, Commissioner and the Official Delegate-Inspector and provide them with tickets electronically.

45.3 Referees, Commissioners and Official Delegates-Inspectors shall take their sport equipment in the hand luggage on airplane. Referees, Commissioners and Official Delegates-Inspectors shall not check in their sport equipment.

45.4 Remuneration of Referees, Commissioner and Official Delegate-Inspector

45.4.1 The League will pay Referees, Commissioner and the Official Delegate-Inspector for their work at each Match at each stage of the Championship as follows:

- Referees (3 persons) – thirty-seven thousand (37,000) RUB each, Commissioner (1 person) –twenty-four thousand (24,000) RUB; the official Delegate-Inspector – eleven thousand (11,000) RUB.
- In the event of the club's failure to appear and drawing up "FORFEIT" official scoresheet for the Match, the Referees, the Commissioner and the Official Delegated Inspector are paid as if they had played a game.
- In case if due to the force majeure situation the Game was served by two (2) Referees, the payment is made at the rate of fifty-five thousand five hundred (55,500) RUB to each of them.

46 ARTICLE 46 CONTROL OF REFEREES

46.1 General terms

46.1.1 The Control of Referees is an independent working body that considers issues related to the quality and objectivity of refereeing the games of the Championship.

46.1.2 The main functions of the Control of Referees are:

- Analysis of the quality and objectivity of refereeing (work of Referees, Commissioners, Table officials) of individual Championship Matches at the request of the League.



VTB UNITED LEAGUE REGULATIONS

SEASON 2020-2021

- Compilation of the results of the analysis of the Matches of the Championship of reports and submission to the Directorate;
- Preparation of recommendations to the Directorate about the professional qualities of the Referees, Commissioners, Table Officials.

46.2 Composition of Control of Referees

46.2.1 The quantitative and personal composition, as well as the Chairman of the Control of Referees, shall be approved by the General Director of the League. In case of voluntary resignation of the authority of a member of the Control of Referees or the impossibility of performing the duties of a member of the Control of Referees for health reasons, the General Director has the right to replace the outgoing member of the Control of Referees by its own decision.

46.2.2 The Control of Referees shall include the most authoritative citizens in the field of basketball of the Russian Federation and other countries who have established themselves as experienced Referees / basketball commissioners with a valid FIBA Referee / commissioner license and experience in officiating and/or holding international high-level basketball competitions.

46.2.3 The chairman of the Control of Referees exercises overall supervision over the work of the Control of Referees, sends materials to the members of the Control of Referees, prepares the report and sends it to the Directorate.

46.3 The procedure for submitting documents for consideration by the Control of Referees reviewing the quality and objectivity of the officiating of the Championship Matches.

46.3.1 The basis for the consideration by the Control of Referees of the quality and objectivity of officiating of the Championship Matches are the following documents:

- Requests by the League;
- Protests lodged by Clubs in accordance with these Regulations and FIBA Official Basketball Rules (in case of sending a protest to the Control of Referees by the League);
- Written appeals of the Clubs to the Control of Referees on unqualified or biased refereeing.

46.3.2 Appeals of the Clubs participating in the Championship regarding unqualified or biased refereeing at the Championship game shall be submitted to the League within seven (7) business days after the date of this game.

The Club that submitted the application shall fulfill the following conditions:

- to provide a video recording of Match moments, which served according to Club's opinion as the basis for submitting the application, with their description in writing;
- to pay on the bank account of the League a fee in **the amount of thirty thousand (30,000) RUB.**

46.3.3 To analyze the quality and objectivity of the officiating of the Championship Match, the League provides members of the Control of Referees with the following materials:

- application of the Club or the request of the League or protest documents in case of a protest;
- video recording of the Match;
- video recording of the Match moments with their description submitted by the Club;
- completed report of the Commissioner related to watching of the Match video-recording.;

46.4 Working order of Control of Referees.

46.4.1 The Control of Referees in its activity is guided by FIBA Official Basketball Rules and these Regulations.

46.4.2 By the decision of the Chairman of the Control of Referees, the work of the commission members is carried out either in absentia (without joint attendance) or in the form of joint presence at a meeting of the Control of Referees.



VTB UNITED LEAGUE REGULATIONS

SEASON 2020-2021

In the case of an absentee meeting of the Control of Referees, its members work individually. Members of the Control of Referees review documents provided by the Chairman of the League.

A member of the control of Referees shall send a conclusion to the Chairman of the Control of Referees within 48 hours, after receiving the relevant material from the Chairman of the Control of Referees if there is no other time limit, on the materials provided.

46.4.3 In case of the meeting of the Control of Referees in the form of a look-up of the joint presence of the members of the Control of Referees meeting is competent if it is attended by more than half the members of the Control of Referees.

46.4.4 Decisions are made by a simple majority of votes of the members of the Control of Referees. If the votes are equal, the vote of the Chairman of the Control of Referees is decisive. A member of the Control of Referees, who does not agree with the majority's decision, may state in writing its dissenting opinion, which is attached to the case materials.

After making a decision, members of the Control of Referees shall not comment on the internal process of discussion, decision-making and the position of the members of the Control of Referees in the media. A member of the Control of Referees, which does not agree with the majority's decision, has no right to express (publish) its dissenting opinion in the media.

46.4.5 Revision of the decision taken by the Control of Referees can be carried out in connection with the provision of new facts and evidence that could significantly affect the decision taken earlier by the Control of Referees.

46.4.6 Report of the Control of Referees shall be sent to the Directorate not later than seventy-two (72) hours from the receipt of materials for consideration by the members of the Control of Referees.

46.4.7 No later than five (5) business days after the payment is received to the League account, the report of the Control of Referees together with the decision of the Directorate is sent to the Club that has applied to the Control of Referees.

46.4.8 The League bears the expenses for the work of the Control of Referees in the following amount:

- Chairman of the Control of Referees (1 person) – fourteen thousand (14,000) RUB for one (1) game of the Championship;
- Members of the Control of Referees – seven thousand (7,000) RUB for one (1) game of the Championship;



VTB UNITED LEAGUE REGULATIONS

SEASON 2020-2021

CHAPTER 8

INFORMATION AND CHAMPIONSHIP STATISTICAL SUPPORT

ARTICLE 47 STATISTICS OF MATCHES AND INFORMATION SUPPORT OF THE CHAMPIONSHIP

47.1 Clubs have the obligation to conduct statistics of the home Matches by Table Officials (operator-statistician and statisticians) and send textual online broadcasting of the Match to the League website using a software provided by the League (FIBA LiveStats) taking into account requirements on conducting statistics by Table Officials provided by the League. After each quarter, operator-statistician and statisticians must print and hand over statistical reports to teams' representatives present at the Match, Commissioner and Match Official Delegate-Inspector.

Each Club shall appoint a person responsible for statistics of home Matches, who shall stay close to the playing court and be in constant contact with the League during the Match for taking operative decisions on issues related to statistics.

A fine in the amount of two hundred thousand (200,000) RUB will be imposed on the Club for violation.

47.2 The Host Club shall provide the following equipment and relevant instructions for conducting statistics:

- Computer with Windows 7, 8 or 10 (32- or 64-bit or higher) operating system, central processor Dual Core I5 or higher, core memory (RAM) from 4Gb or higher, hard disc of at least 1Gb, monitors at least 15" and resolution at least 1024 x 768, Ethernet network interface card 10 Mb/sec. Internet access should be secured by a designated line (cable) with a guaranteed capacity at least 10 Mb/sec;
- Laser printer with speed of at least 20 pages/minute and sufficient quantity of consumables (cartridges);
- At least 150 sheets of A4 paper for printing statistical reports;
- At least two electric plugs for switching computer and printer;
- All equipment should function properly and be ready to work sixty (60) minutes prior to the Match;
- Similar equipment (including reserve designated line for internet access) should be reserved in case the abovementioned equipment fails.

47.3 Requirements to the Championship information support

47.3.1 Every Club must have:

- An official Club website;
- Official Club accounts in social media;
- Operative e-mail address connected with the website of the Club;
- Manager responsible for official Club internet website;
- Manager responsible for official Club accounts in social media.

47.4 Requirements to the official Club internet website

47.4.1 The Club shall have an official internet website reflecting current information in two languages: home country of the Club and English.

A fine in the amount of two hundred thousand (200,000) RUB will be imposed on the Club for violation.

47.4.2 The Club shall take responsibility to regularly update information about Club, League and Championship on their official website in two languages: home country of the Club and English



VTB UNITED LEAGUE REGULATIONS

SEASON 2020-2021

including but not limited to latest news about the Club team, calendar and results of Matches, kick off time of Club home Matches, reports on Matches of the Championships with the participation of the Club team, composition of the Club team with Players photographs.

The Club shall take responsibility for validity of information placed on the official Club website.

A fine in the amount of one hundred and fifty thousand (150,000) RUB will be imposed on the Club for violation.

On the first day of each month during the season, League shall check implementation of this clause 47.4.2 of Art. 47 by the Club. A monthly fine may be imposed on the Club until the violation is rectified.

47.4.3

The following information shall be reflected on the official Club internet website:

- name of the Club, brief history of establishment and activity, contacts including address, telephone number, e-mail address;
- list of Club employees and their positions, contact telephone numbers and e-mail addresses;
- list of sport facilities (main and reserve) including address, photograph, telephone and fax numbers;
- list of Club team Players, their names and surnames, position, date of birth, height, weight, citizenship (if there are several, the one declared for participation in the Championship Matches shall be the first in the list);
- list of Coaches, Administrators and Medical personnel of the Club team, their names and surnames, position, date of birth, citizenship (if there are several, the one declared for participation in the Championship Matches shall be the first in the list).

A fine in the amount of one hundred and fifty thousand (150,000) will be imposed on the Club for violation.

47.4.2

On the main page of the Club's website there shall be a League logo with a direct indexed link to the League website.

A fine in the amount of one hundred thousand (100,000) will be imposed on the Club for violation.

47.4.3

On the official website and social networks of the Club, it is prohibited to publish materials that discuss the topic of refereeing Championship Matches as well as abusing honor, dignity and business reputation of the League, representatives of the League, Referees, Players, Trainers, Officials and the Club's Team Followers.

For violation, a fine in the amount of five hundred thousand (500,000) RUB is imposed on the Club.

Note: a Club can be held liable for violation of this article in the period from the date of approval of the composition of participants in the Championship and the formation of the composition of the League Board in 2020 until the formation of a new composition of the League Board in 2021, i.e. not limited to the terms of the Championship.

47.5

Requirements to accounts in social media:

47.5.1

Club shall have accounts in at least four (4) social media – Twitter, Instagram, Youtube and VK (for Russian Clubs) or Facebook (for Foreign Clubs).

If the Club does not have at least two verified accounts in social media a fine in the amount of one hundred (100,000) RUB is imposed on the Club.

During the season of the 1st day of each month, Directorate checks the execution by the Club of this clause 47.5.1 of Art. 47 of the Regulations. A fine can be imposed on the Club monthly until the violation is eliminated.

47.5.2

Club shall regularly provide all relevant information about Club, the League and Championship, the latest news about the Club team, calendar and results of Matches in social media;



VTB UNITED LEAGUE REGULATIONS

SEASON 2020-2021

- 47.5.3** It is prohibited to provide or disclose confidential information in relation of a Player, Coach, Official or the League in the social media.
- 47.5.4** Clubs are required to promote information provided by the League in their social networks at the request of the League, subject to the following conditions:
- placement of information – no more than two (2) times a month in each social network of the Club;
 - the time when the Club publishes such information is within 24 hours after the League sends a request to the Club;
 - such information shall be related to the activities of the League and/or the conduct of the Championship and shall not be associated with the League's sponsors.
- For violation, a fine in the amount of one hundred thousand (100,000) RUB is imposed on the Club.**
- 47.5.5** Not later than thirty (30) calendar days prior to the Championship, Club Press-officer shall provide the League with the list of all Players of the Club with links to social media. In case of additional entry, Club has to inform the League and submit updated list within three (3) days with links to social media of all Club Plyers.
- 47.5.6** In the official accounts of the Club, Officials, Team Followers, Players, Coaches, as well as family members of Officials, Team Followers, Players, Coaches (spouses, parents, children, sisters and brothers, other relatives) registered on social networks, it is prohibited to publish materials containing discussion of the topic of refereeing Championship Matches, as well as affecting the honor, dignity and business reputation of the League, representatives of the League, Referees, Players, Coaches and officials of other Clubs.
- For violation, a fine in the amount of three hundred thousand (300,000) RUB is imposed on the Club.**
- Note:** a Club can be held liable for violation of this article in the period from the date of approval of the composition of participants in the Championship and the formation of the composition of the League Council in 2020 until the formation of a new composition of the League Council in 2021, i.e. not limited to the terms of the Championship.
- 47.5.7** The League has the right to monitor media content in the Club social media. Clubs have the right to provide the League with information placed in social media in relation to Championship and Clubs, which the Club consider appropriate, to the e-mail address: media@united-league.com



VTB UNITED LEAGUE REGULATIONS

SEASON 2020-2021

CHAPTER 9

PRESS SERVICE OF THE CLUB.

MASS MEDIA (MEDIA)

ARTICLE 48 PRESS SERVICE OF THE CLUB.

- 48.1** Each Club shall have a press-service responsible for media communications and media relations including the Head of Club Press-service (hereinafter – press officer), other employees. His/her contacts shall be sent to the League no later than thirty (30) calendar days before the start of the Championship. The change of the Press-officer shall be notified to the League not later than twenty-four (24) hours before the Championship Match followed after the change of Press-officer starts. The necessary requirement for the press officer of the Club is fluency in English.
- 48.2** Press service of the Club shall ensure the accreditation and work of media representatives during the Championship games, facilitate the work of the press service of the League, coordinate the Club's relations with the media, provide media and fans with timely information about the Club. The Club's press service shall ensure that the requests of the League's press service are fulfilled.
- 48.3** During the Championship Matches, the Club Press Service is responsible for providing the press service of the League with pre-Match citation of the Club team coach, holding press conferences, providing media with pre-Match protocols and statistics, coordinating the transfer of photos from the Match to the Press Service of the League.
- 48.4** The press officer of the Club coordinates with the Club security service the rules of access to the teams changing rooms at the end of the Match and, if necessary, issues media special passes to dressing rooms.
- 48.5** If the participant of the press conference held by the Club does not speak English, the duty of the press officer is to provide a qualified translation from the native language of this participant into English.
- 48.6** Communication of Players and Coaches of the Club on free days with media representatives shall be carried out through the press service of the Club. Communication of Club Players and Coaches with media without agreement with the press service of the Club is not allowed.
- 48.7** Each Club shall submit to the League at least fifteen (15) calendar days before the start of the Championship information about the team (a brief history, the club's management, the address of the office, the address and the names of sport facilities where the Club will host Championship of the League Matches). Also, the Club provides a list of Players and Coaches in Russian and English with pronunciation transcriptions indicating the citizenship, height, weight, and game number, position and a brief biographical note for each Player (place of birth, previous clubs, playing in national team, sporting achievements, statistics, interesting facts). Information shall be sent to e-mail: media@united-league.com. Club shall promptly inform the League on all changes.
- For violation, a fine in the amount of one hundred thousand (100,000) RUB is imposed on the Club.**



VTB UNITED LEAGUE REGULATIONS

SEASON 2020-2021

ARTICLE 49 PHOTO SERVICE OF THE CLUB.

- 49.1** Each Club is required to have a photo service including a photographer and/or another employee who is authorized by the Club to implement provisions of this article 49 of the Regulations.
For violation, a fine in the amount of one hundred thousand (100,000) RUB is imposed on the Club.
- 49.2** The Club is required to photograph all home Championship Matches.
For violation, a fine in the amount of one hundred thousand (100,000) RUB is imposed on the Club.
- 49.3** The League will provide all Clubs with access to the League ftp-server for recording of the home Matches photographs at least seven (7) days prior to the Championship.
Photos taken at Championship Matches sent to the League may be used by the League, other Clubs and by partners and sponsors of the League including mass media for any purposes compliant to copyright legislation, and compulsory indication of the author's name and surname and source of the photograph.
- 49.4** Each Club has to record on the League ftp-server at least forty (40) diverse photographs from each home Championship Match.
Photographs should display Players and Coaches of the Host Club and the Guest Club. Players shall be shown in attack moving towards the ring with photographer behind front line. Photographs should have original resolution without any cropping or processing.
The following requirements shall be fulfilled when sending recorded photographs to the League ftp-server as per number of photographs:
- Players of the Host Club – at least 21 photos;
 - Players of the Guest Club – at least 9 photos;
 - Coach of the Host Club – at least 2 photos;
 - Coach of the Guest Club – at least 2 photos;
 - Group of supporters, spectators, other Match participants – at least 6 photos.
- For violation, a fine in the amount of one hundred thousand (100,000) RUB is imposed on the Club.**
- 49.5** Each Club shall record home Championship Matches photographs on the League ftp-server:
- In the interval between the second and third quarter shall be sent no less than fifteen (15) photographs;
 - Not later than forty (40) minutes after the end of the Match, no less than twenty-five (25) photos.
- For violation, a fine in the amount of one hundred thousand (100,000) RUB is imposed on the Host Club.**
- 49.6** Photographs uploaded by the Club on the League ftp-server may coincide with photos published on the Club official website, however, not more that by fifty (50) percent of the total amount.
For violation, a fine in the amount of one hundred thousand (100,000) RUB is imposed on the Host Club.
- 49.7** Duties of the Club photo-service shall also include joint work with the League's press-service as well as implementation of its requests and special tasks. The League undertakes to provide photo-service of the Host Club a request or a special task for a specific Match not later than one (1) hour prior to its start.
For violation, a fine in the amount of one hundred thousand (100,000) RUB is imposed on the Host Club.



VTB UNITED LEAGUE REGULATIONS

SEASON 2020-2021

- 49.8** Photo-service of the Host Club take responsibility for the work of photographers accredited to home matches of this Club and will control fulfillment of the following requirements:
Photographers accredited to the Match have the right to install remote cameras behind the backboard, including using black matte paper. It is allowed to install not more than two cameras behind each backboard with priority given to photographers of the Club and the League. Number of cameras may be increased at the discretion of the Press-officer of the Host Club. At the same time, on the day of the Match, photographer or representative of the Guest Club shall notify the Host Club about the camera installation plans, and the Host Club shall provide conditions for the installation. Installation of the camera is conducted no later than two hours before the Match starts. **For violation, a fine in the amount of one hundred thousand (100,000) RUB is imposed on the Host Club.**
- 49.9** Accredited photographers have the right to shoot along the front line, from under the ring, at the corners of the site, from the tribunes, provided that the photographer does not interfere with the Match, players, coaches, referees, table officials, TV partner operators of the League or the Club implementing video shooting of the Match and does not close the view for fans. Photographer of the Guest Club shall have access to his/her team's bench during the Match.

ARTICLE 50 GENERAL PROVISIONS ON MEDIA ACCREDITATION

- 50.1** Accreditation of media representatives at official events of the League (hereinafter – accreditation) is conducted in order to create the necessary conditions for professional activities of media representatives and to improve the quality of coverage of the Championship and other events of the League in the media.
- 50.2** The League shall delegate the right to provide accreditation to home Championship Matches to the Host Clubs.
- 50.3** Accreditation is the basis for the passage and placement of an accredited media representative in a sports facility that is subject to accreditation, as well as for the work of a media representative in the sports facility indicated in the accreditation card or in the rules of conduct of media confirmed during accreditation.
- 50.4** Media can be accredited to all Championship Matches or to a separate Match.

ARTICLE 51 RIGHTS AND RESPONSIBILITIES OF THE LEAGUE IN THE ACCREDITATION OF THE MEDIA

- 51.1** The League provides an opportunity to carry out professional activities to cover the Championship Games in the sports facilities in which the Championship Games are held, exclusively by the media representatives accredited by the Host Club for Championship Matches.
- 51.2** The League has the right to send the Club a written instruction to accredit the League partners for the Championship Matches.
- 51.3** The League has the right to demand in writing from the Club to refuse accreditation of any media or media representative and withdraw their accreditation during the season.



VTB UNITED LEAGUE REGULATIONS

SEASON 2020-2021

ARTICLE 52 RIGHTS AND OBLIGATIONS OF CLUBS REGARDING ACCREDITATION OF THE MEDIA

- 52.1** The Club shall develop and produce accreditation cards at their expense for media accreditation.
- 52.2** The Club shall develop rules of conduct for media representatives at home Matches and determine access zones in sports facilities, taking into account the recommendations of the League.
- 52.3** The Club shall notify the media about the beginning of accreditation for home games not later than thirty (30) days before the start of the Championship Matches, to familiarize the media with the rules of accreditation and conduct of media and post this information on the official website of the Club.
- 52.4** Lists of accredited media representatives shall be submitted by the Club to the League no later than seven (7) calendar days before the start of the Championship.
- 52.5** The Club has the right to refuse accreditation of any media or media representative, as well as to deprive the media or media representative of accreditation on their own initiative or the demand of the League. In this case, the Club shall notify the League and the media in writing.
- 52.6** The Club shall accredit League employees (no more than 4 people) to the Championship Matches in case of receiving a written instruction from the League on accreditation of such employees sent no later than five (5) calendar days before the date of the Match. Accreditation for League employees shall provide access to all areas of the sports facility.
- 52.7** The Club shall accredit partners of the League to the Championship Matches upon receipt a written instruction on accreditation of such partners from the League.

ARTICLE 53 SEASONAL ACCREDITATION PROCEDURE

- 53.1** Seasonal accreditation valid for all Matches of the Championship is individual (with the exception of technical personnel of the TV partner of the League and Clubs.). Transfer of the accreditation card to another media representative for Championship Matches is not allowed. In case of violation of this rule, the accreditation card is withdrawn, and the Media representative is deprived of accreditation.
- 53.2** Accreditation card will be issued to a media representative as a result of accreditation process, containing the following information:
- Full name of the representative of the accredited media;
 - Name of the media;
 - Validity of accreditation.
- 53.3** It is recommended to split accreditation cards for the following types of media activities:
- TV operators and TV reporters of the TV Partner of the League and Clubs;
 - Technical staff of the TV Partner of the League and Clubs;
 - TV operators and TV reporters of other TV and Internet media;
 - Photographers;
 - Representatives of printed and Internet media, radio reporters, representatives of the press services of the clubs of the League.
- 53.4** It is recommended that the seasonal accreditation card be laminated or provided with a plastic pocket and has a clip or ribbon.



VTB UNITED LEAGUE REGULATIONS

SEASON 2020-2021

ARTICLE 54 ONE-TIME ACCREDITATION PROCEDURE

- 54.1** One-time accreditation of the media grants the right to carry out professional activities in a single sports facility on a specific day, which shall be indicated on the accreditation card.
- 54.2** In order to receive a one-time accreditation, the media shall send an official application signed by the head to the press service of the Host Club in the Game, which plans to cover the given media not less than one (1) day before the game.
- 54.3** The Press Service of the Host Club makes a decision to issue a one-time accreditation to the media.
- 54.4** A representative of the media, in case of a positive decision, receives a one-time accreditation for the Game in the Press Service of the Host Club on the day of the game no later than one (1) hour before the game starts.
- 54.5** Media or media representative denied by the League or the Club in seasonal accreditation are not eligible for one-time accreditation.

ARTICLE 55 TERMINATION OF ACCREDITATION

- 55.1** The validity of accreditation is terminated/suspended in the event of:
- termination or suspension of media activities in the manner prescribed by the law of the country in which the media is registered;
 - termination of labor or other contractual relations of a representative of the media with the editorial staff of the accredited media;
 - recall of a media representative by the editorial staff of the accredited media;
 - expiration of the validity period of accreditation.
- 55.2** In the event of termination of employment or other contractual relations of an accredited media representative with the media or revocation by the editorial decision, the latter shall inform the Club and return the accreditation card. The media has the right to apply for accreditation of another representative.
- The validity of accreditation may be suspended with the withdrawal of the accreditation card, if the editors of the media or an individual representative of this media have violated these Regulations, as well as the rules of conduct at the Championship games, there are disseminated untrue information undermining the business reputation of the League, as well as discrediting honor, dignity and business reputation of employees of the League or Clubs participating in the Championship.
- 55.3** The decision to suspend the accreditation of a media representative will be taken by the Club, documented in writing and sent to the League.

ARTICLES 56 RIGHTS AND OBLIGATIONS OF MEDIA REPRESENTATIVES

- 56.1** Accreditation is the basis for the passage of a representative of the accredited media to the sports facility where the accredited Club conducts home games, as well as for the work of the media representative on these Matches.
- 56.2** Representative of the accredited media has the following rights under his accreditation and rules of media conduct:



VTB UNITED LEAGUE REGULATIONS

SEASON 2020-2021

- Visit the Championship Matches, and other official League events related to the Championship;
- Attend the process of preparation and organization of the Championship Games upon agreement with the Club;
- in case of receiving one-time accreditation – to attend the Championship Match, which is subject to the accreditation, the process of preparation and organization of this Match;
- to use press tribune in the sports facilities, room for press-conference, press center and mixed zone for their professional duties;
- to request from the Clubs and the League information necessary for the performance of their professional duties in the framework of the laws on the mass media;
- to participate in the post-game press conference of the Team Coaches;
- to interview the Players and Coaches of both teams prior to the Game in agreement with the Clubs;
- to communicate in the mixed zone with the Players and Team Coaches who participated in the game, after the end of each Game of the Championship, in accordance with the restrictions established by accreditations for this type of media;
- have access to teams' changing rooms after the game ends;
- to make video shooting, photographing and audio recording of the Players, Coaches and other Club officials inside the sports facilities during the Games.

56.3 Press center, press tribune, mixed zone, press conference room, team changing room – places for work of accredited representatives of the media, employees of the Clubs and League, related to interaction with the press. In these places, ethical norms and rules of conduct for reporters established by the Club shall be observed.

It is not allowed to show cheerleading emotions by representatives of the media and other persons who are due to their official position in the press box, mixed zone, changing room, press center and press conference room, in relation to any of the teams participating in the game, beyond the scope of professional journalistic ethics.

56.4 The representative of the accredited media, in accordance with the limitations of its accreditation, shall:

- in the conduct of professional activities, respect the rights, legitimate interests, honor and dignity of the employees of the League;
- verify the reliability of the information communicated to him/her;
- satisfy the requests of the persons who provided information about the indication of its source, as well as the authorization of the quoted statement, if it is first announced;
- inform citizens and officials about the implementation of audio and video recording, film and photography with their participation;
- present in the implementation of professional activities, upon request, an editorial certificate or other identity document and the authority of a media representative;
- not disseminate information that does not correspond to reality, discrediting honor, dignity and business reputation of League and Club employees, as well as information that does not correspond to reality, undermining the business reputation of the League and Clubs;
- not use professional opportunities to conceal information or falsify publicly significant information, spread rumors under the guise of reliable messages, collect information in favor of an unauthorized person or an organization that is not the media.

56.5 Video shooting, photographing and audio recording of Players, Coaches, Club and League representatives, other participants of the Championship during the Championship Matches can be carried out by accredited media representatives exclusively in accordance with the restrictions



VTB UNITED LEAGUE REGULATIONS

SEASON 2020-2021

established by the law on mass media acting at the territory of the Host Club country and rules of conduct of media.

56.6

Equipment for Media and media representatives shall:

- Meet safety requirements;
- Not impede movements of Match participants and spectators;
- Not impede staging of the Match, Players, Coaches, Referees, Table officials, Operators of the TV Partner of the League or the Club fulfilling video-shooting of the Match and cover view for supporters.

ARTICLE 57 CLUBS AND MEDIA COOPERATION AT THE MATCHES OF THE CHAMPIONSHIP

57.1

Press-conferences

57.1.1

The Club has the right to hold a press conference before the game no later than one (1) day before the date of the Game. A press conference can be organized in a sports facility or in another place located in the city where Match will be held. The Team Coach of the Club and any other representatives of the Club shall attend the press conference.

57.1.2

Not later than twenty-five (25) minutes after the end of each Match of the Championship, the Host Club shall hold a press conference. The Host Club and the Guest Club are required to ensure the participation of a team Coach of the Host Club and Guest Club and one (1) Player included in the Technical entry for this Match.

Press officer of the Host Club is responsible for organization of press conference.

It is allowed to organize a press conference in the format of a flash interview in cases when the Host Club or League organized video-shooting of the press conference and its broadcasting on internet. In this case, flash interview will be held at the banner for interview (press wall) with logos of sponsors and partners of the League and Host to be placed there.

Sole participation of Coaches of the Club teams in press conferences in cases when Players of these teams took part in the flash interview organized by a TV company after the Match.

For failure to fulfil provisions of this Article in relation to conduct of a press conference, **a fine in the amount of one hundred thousand (100,000) RUB** is imposed on the Host Club.

A fine in the amount of one hundred thousand (100,000) RUB will be imposed on Clubs for refusal of a Coach or Players to participate in the press conference or flash interview.

57.1.3

If a Team Coach or a Player was disqualified during the Game, this Coach or Player shall not have the right to participate in the press conference. Instead, the Club shall secure participation of an Assistant Coach and/or Team Captain and/or another Player.

A fine of one hundred thousand (100,000) RUB shall be imposed on the Club for a violation.

57.1.4

During press conference, Press Officer of the Club should refuse any questions related to officiating of the Championship Matches and prevent replies by the Coaches and Players participating in the press conference to questions related to officiating of the Championship Matches.

For violation, a fine in the amount of one hundred thousand (100,000) RUB is imposed on the Club.

57.2

Interview. Flash interview

57.2.1

Coaches, Players, Team Followers and Officials of the Club are entitled to give interview to media representatives.

Media representatives have the right to access dressing rooms of the Host Club and Guest Club not later than seven (7) minutes after each Match. Press officer or representative of a Club team should



VTB UNITED LEAGUE REGULATIONS

SEASON 2020-2021

inform Players on visit of dressing rooms by media representatives and whether female media representatives will be among them. Then media representatives receive access to dressing rooms. Press service of the Host Club shall inform security on the rules of access to dressing rooms by media representatives in order to control access.

Media representatives may stay in the dressing room not more than fifteen (15) minutes.

Number of media representatives allowed to visit Players dressing rooms of the Host Club will be confirmed by the Host Club while the Guest Club shall confirm for their dressing room taking into consideration its space. If space of the dressing room is not sufficient, then, Press Officer or team representative of the Club has the right to limit minimum number of media representatives to no more than five (5) who can stay in the dressing room at the same time.

For violation of this clause 57.2.1 of Article 57 of these Regulations, a fine in the amount of one hundred thousand (100,000) RUB is imposed on the Club.

57.2.2 At least one Player of each team should take part in a brief (flash interview) with media representatives in mixed zone immediately after the end of the Match on the way to dressing room.

57.3 Clubs responsibility during press conferences, interview, public utterance

At press conference and during interview, it is forbidden for representatives of the Clubs (Officials and other persons) and members of their teams (Coaches, Players, Team followers and other persons) to express statements abusing honor, dignity and business reputation of the League, Players, Coaches and other Team Followers, Club Officials, Referees and other participants of the Championship. It is forbidden to make comments and discuss officiating of the Championship Matches during press conferences and interview.

For violation, a fine in the amount of five hundred thousand (500,000) RUB will be imposed on the Club.

For a repeated violation – a fine in the amount of one million (1,000,000) RUB will be imposed on the Club.

Note: a Club can be held liable for violation of this article in the period from the date of approval of the composition of participants in the Championship and the formation of the composition of the League Council in 2020 until the formation of a new composition of the League Council in 2021, i.e. not limited to the terms of the Championship. Violation of this clause of the Regulations will be considered repeated if the Club has already been brought to responsibility by the Directorate within the specified time period for violation of this clause of the Regulations.

ARTICLE 58 FACILITIES FOR OPERATION OF ACCREDITED MEDIA AT THE MATCH VENUE

58.1 Media tribune

58.1.1 The Club shall provide accredited media representatives with sufficient number of seats (at least twenty (20)) at the tribune close to playing court in order to work during the Match. These places shall be equipped with:

- tables and chairs (seats) for every media representative;
- Internet access;
- electric sockets (at least one for each media representative);

58.1.2 Places at media tribune for media representatives shall be located as close as possible to the playing court and changing rooms of teams. From these seats, unobstructed sight of the playing court and the scoreboard shall be ensured.

58.1.3 Access to press seats at media tribune shall be provided only to accredited media.



VTB UNITED LEAGUE REGULATIONS

SEASON 2020-2021

For violation of clauses 58.1.1–58.1.3 of Article 58 of these Regulations, a fine in the amount of one hundred thousand (100,000) RUB is imposed on the Club per each clause.

58.2 Press-conference room

58.2.1 The Host Club shall provide a room for a press conference, which shall meet the following requirements:

- area— at least thirty (30) sq. meters;
- location near the Players changing rooms;
- tables and chairs for participants of a press conference (at least, 2 tables and 4 chairs; Press wall has to be behind tables and chairs to display logos of the League and the Host Club sponsors and partners;
- chairs for media representatives (at least thirty (30)).

For violation of clause 58.2 of Article 58 of these Regulations, a fine in the amount of one hundred thousand (100,000) RUB will be imposed on the Club.

58.3 Press-center (a working facility for media).

58.3.1 The Club is recommended to provide press center to media representative: a working area near the playing court accessible only to the media. Media representatives should have the access press center one (1) hour before the Match starts and at least two (2) hours after the end of the Match.

The room shall be equipped with:

- tables and chairs for no less than twenty (20) people;
- Internet access;
- electric sockets (at least one for each media representative);

In the absence of a press center, the Club shall provide media with the opportunity to work at the media tribune. In this case, media representatives should have access to the media tribune one (1) hour before the Match and at least two (2) hours after the end of the Match. During this time, media representatives shall be provided with lighting, electricity in the sockets and internet access.

For violation of clause 58.3 of Article 58 of these Regulations, a fine in the amount of one hundred thousand (100,000) RUB is imposed on the Club.

58.4 Mixed zone

58.4.1 The Host Club shall provide mixed zone in the sport facility. Mixed zone is an area where media representatives can interview (flash interview) Players and Coaches. Recommended area of a mixed zone is thirty (30) sq.m.

Mixed zone should meet the following requirements:

- Mixed zone should be located on the way of Players and Coaches from the playing court to team dressing rooms. Host Club is obliged to agree upon the location of a mixed zone with the League.
- Press wall should be installed in the mixed zone and display logos of the League and the Host Club sponsors and partners.

For violation of clause 58.4 of Article 58 of these Regulations, a fine in the amount of one hundred thousand (100,000) RUB is imposed on the Club.



VTB UNITED LEAGUE REGULATIONS

SEASON 2020-2021

CHAPTER 10

TV SHOOTING OF THE CHAMPIONSHIP MATCHES AND PRODUCTION OF TV SIGNAL

ARTICLE 59 GENERAL TERMS

- 59.1** The League has exclusive rights to broadcast the Championship by transmission of image and/or sound using any methods and/or any technologies as well as by recording of broadcast and/or photo-shooting of the Championship and by any other rights to broadcast the Championship related anyhow with the status of the Championship Organizer. Exclusive rights of the League in relation to broadcasting of the Championship cover, including but not limited, official ceremonies of the opening and closing of the Championship, Matches of the Championship, other Matches and events in connection with the Championship held by the League and/or the Clubs, including the Match of All Stars.
- 59.2** Rights to broadcast the Championship can be used by the third parties based only on the League authorization or agreements in written form on purchase of these rights by the third parties from the League.
- Clubs are not entitled to use on their own and/or provide to the third parties any fragments of the Championship Matches without authorization by the League in writing, i.e. live and/or delayed TV broadcast, highlights, summary, dangerous situations.
- The Clubs have the right to post on their official website broadcasts and/or fragments of broadcasts of Championship Matches involving their team only using the online player of the League or a League partner.
- Clubs have the right to publish on their official website and in the Club social media fragments of the Championship Matches shot by the Club no longer than 3.5 minutes. However, shooting angle should not coincide with the angle of the major camera of TV partner of the League or the Club.
- The Clubs have the right to use fragments of the broadcast of Championship Matches with the participation of their team and/or video footage taken independently from an angle different from that of the leading camera of the TV partner of the League or Club to create their own video footage. The resulting video materials shall meet the following criteria:
- the total content of fragments of a single Championship Match is not more than 3.5 minutes in one video (regardless of the angle or nature of the fragments);
 - placement on the Club's official website or social networks;
 - use only for non-commercial purposes.
- 59.3** The League shall organize TV shooting of the Championship Matches held in the territory of the Russian Federation and production of TV signal of these Matches and also transmission of TV signal of these Matches to national and international partners of the League.
- 59.4** Foreign Clubs shall arrange on their own and at their expense TV shooting of home Championship Matches held beyond the territory of the Russian Federation and production of TV signal of these Matches as well as transmission of TV signal of these matches to National and international partners of the League. Foreign Clubs and/or TV partners of Foreign Clubs who are authorized by them to arrange video shooting, production of TV signal and transmission of this signal, have to be guided by Annex 13 to these Regulations.
- 59.5** The League independently searches for TV partners for TV video shooting of the Championship Matches held in the territory of the Russian Federation, production of TV signal of these Matches



VTB UNITED LEAGUE REGULATIONS

SEASON 2020-2021

and its transmission to national and international partners of the League. TV partner of the League shall be guided by Annex No. 13 to these Regulations.

59.6 The League shall specify Match category according to Annex 13 to these Regulations for TV video shooting, production of TV signal and its transmission to national and international partners of the League and the Club and notify Clubs not later than fifteen (15) calendar days prior to the specific Match.

59.7 The League shall notify Clubs on placement of Championship Matches for broadcasting on the channels not later than ten (10) calendar days prior to specific Match.

59.8 Clubs shall accredit representatives of TV Partner of the League for home Matches that have concluded a contract with the League on television broadcasts, to work at the Championship Matches and/or other Matches broadcasted on these TV channels and provide them with all assistance in their work.

The League can authorize Clubs to fulfil additional responsibilities in order to assist representatives of the League TV partner including but not limited to interview with Players (Coaches, Team followers and Club Officials) prior to the Match or after, access to dressing rooms prior to the Match and after.

ARTICLE 60 RUSSIAN HOST CLUB OBLIGATIONS

60.1 Each Russian Host Club take the following responsibilities in relation to home Championship Matches:

- Implement the League exclusive rights to organize any video shooting and audio recording including TV and radio broadcasting of the Championship Matches. Prevent video shooting and audio recording unauthorized by the League in the sport facility on the Match day or other cases of violation of the League exclusive rights;
- Provide conditions for connection of the main and reserve sport facility of the Host Club to fiber-optic link used by the League TV Partner at the expense of the Host Club and if not available, then provide laying and link connection at the expense of the Host Club;
- Provide placement of transmitting equipment switched to fiber-optic link of the League TV Partner at the main and reserve Club sport facility at the expense of the Host Club.
- Provide parking space for OB vehicles and television equipment and ensure its safety. The parking lot shall be as close as possible to the venue of the Game and be free for use twenty-four (24) hours before the Game. For the DSNG (digital satellite newsgathering), an open-horizon territory in the south direction adjacent to the parking zone of the out-of-stage vans shall be allocated. Such a place shall be free from large barriers (buildings, walls, trees, etc.) in all directions. From the moment of arrival to the parking lot of the first car and until the last car leaves at the parking lot, safety shall be ensured.
- Provide the placement of television equipment in the sport facility (stationary machines, cameras, sportscasters positions, equipment for computer-based broadcasts, etc.);
- Provide the necessary connections to the power supply at sport facility;
- Provide the use of embedded television communications. In the absence of such, ensure the possibility of laying the necessary cable of the League TV Partner;
- Provide access to the premises of the sport facility, required for TV video shooting;
- Provide a dedicated access channel to the Internet for the needs of OB vehicles with a throughput of at least 100 Mbit/s;



VTB UNITED LEAGUE REGULATIONS

SEASON 2020-2021

- Provide the possibility to build platforms for the installation of television cameras and the unimpeded laying of low-current and power cables and the placement of television equipment both outside and directly at the venue of the Game, including through the possible temporary reduction of seats.
- Ensure the operation of two independent sources of energy supply in the venue of the game. Power supply (and in emergency cases) shall be delivered to the OB vehicles parking area, television cameras, sportscasters' positions, places for short interviews, television studios, press conferences. The minimum power of each of the feeders (main and backup) used to connect the television equipment shall be at least 70 kW. The quality of electrical energy in the power supply network and industrial premises (~ 380/220 V) shall comply with the standards in accordance with the current GOST.
- To provide for the possibility of organizing a commentary position, which includes: a table, 2 chairs, a 220-watt power supply.

In case of non-compliance with requirements, a fine in the amount of three hundred thousand (300,000) RUB is imposed on the Host Club.

If failure to comply with these requirements resulted in the failure of the televised broadcast of the Match, a fine in the amount of 500,000 (five hundred thousand) RUB is imposed on the Host Club.

60.2

Russian Clubs take responsibility to prevent obscene and provocative remarks by Players, Coaches, Assistant Coaches, Team Followers and Club Officials in television broadcast, violating honor, dignity and business reputation of the League, Referees, Coaches, Players, other participants of the Championship and spectators.

In the event of a violation, a fine in the amount of five hundred thousand (500,000) RUB is imposed on the Club.

ARTICLE 61 FOREIGN HOST CLUB OBLIGATIONS

61.1

Each Foreign Host Club, in relation to home Championship Match, shall have valid Agreement with the TV Partner on TV Video shooting of home Championship Matches, production of TV signal of these Matches (HD video with graphics + intersound) according to Annex 13 to the Regulations and category of the specific Match approved by the League followed by its lifting to the European satellite and unimpeded (free) access by the League TV Partner.

In case of violation, a fine in the amount of one hundred thousand (100,000) RUB is imposed on the Host Club.

For the production of a signal in the SD format, a fine in the amount of five hundred thousand (500,000) RUB is imposed on the Host Club.

61.1.1

Send the parameters of European satellite which will receive signal of the home Championship Match to the League not later than three (3) days before the date of the Match.

In case of violation, a fine in the amount of one hundred thousand (100,000) RUB is imposed on the Host Club.

61.1.2

Prevent delays or disruptions in production of TV signal of home Match which may result in delays and failure of the Match TV broadcast;

For disruption of TV broadcast, a fine in the amount of five hundred thousand (500,000) RUB will be imposed on the Host Club for the first violation, which will be deducted from the club's bonus; five hundred thousand (500,000) RUB for a repeated violation, however, one million (1,000,000) RUB (for the first and second violations) shall be transferred to the



VTB UNITED LEAGUE REGULATIONS

SEASON 2020-2021

account of the League within five (5) business days from the receipt of written notification of the Club about the violation; eight hundred thousand (800,000) RUB for any subsequent violation, which shall be transferred to the account of the League within five (5) business days from the receipt of a written notice of the Club on the violation.

For the delay of TV broadcasting, a fine in the amount of five hundred thousand (500,000) RUB is imposed on the Host Club.

61.2 Foreign Clubs take responsibility to prevent obscene and provocative remarks by Players, Coaches, Assistant Coaches, Team Followers and Club Officials in television broadcast, violating honor, dignity and business reputation of the League, Referees, Coaches, Players, other participants of the Championship and spectators.

In case of a violation, a fine in the amount of five hundred thousand (500,000) RUB is imposed on the Club.

ARTICLE 62 FINANCING OF MATCHES VIDEO SHOOTING

62.1 Funding of TV video shooting of the Championship Matches held in the territory of the Russian Federation, production of TV signal and transmission of TV signal of such Matches to national and international League Partners will be fulfilled from two sources: at the expense of the League and at the expense of each Russian Club **in the amount of two million five hundred thousand (2,500,000) RUB** (from each Club).

62.2 Funding of TV video shooting of the home Championship Matches held outside territory of the Russian Federation, production of TV signal and transmission of TV signal of such Matches to national and international League Partners will be fulfilled at the expense of each Foreign Club participating in the Championship (in relation to home Matches of such Club).

62.3 Revenues received by the League as a result of transfer of rights to broadcast the Championship by the third parties, will be sent by the League for its statutory goals and objectives (including the conduct of the Championship and increase of its Premium fund).



VTB UNITED LEAGUE REGULATIONS

SEASON 2020-2021

CHAPTER 11

SANCTIONS, PROTESTS AND DISCIPLINARY PUNISHMENTS

ARTICLE 63 PROTESTS

63.1 General terms

63.1.1 A team may file a protest if its interests have been adversely affected by:

- a) an error in scorekeeping, time-keeping or shot clock operations, which was not corrected by the referees;
- b) a decision to forfeit, cancel, postpone, not resume or not play the game;
- c) a violation of the applicable eligibility rules.

63.2 Practice and procedures for filing a protest

63.2.1 The procedure for filing a protest is determined by the section "C–Procedure for filing a protest" of FIBA Official Basketball Rules.

63.2.2 Procedure for filing a protest:

- Captain of the team filing a protest shall not later than 15 minutes following the end of the Match inform the Chief referee on their intention to file a protest and sign the scoresheet in the column "Captain's signature in case of a protest".
- Club/team which filed a protest shall explain in writing the reason of protest indicating the appealed action or a playing situation not later than one (1) hour after the end of Match in order to confirm the protest.

A draft of the protest: "To: Head of Directorate/League, Commissioner of the Match from (name, surname, position, name of the Club). Club _____ files a protest against the result of the Match among teams _____ and _____. *Explanation of the subject/reason of protest* _____ Date. Signature.

Reasons for filing a protest and detailed circumstances related to violation of provisions of these Regulations and "FIBA Official Basketball Rules" should be explained in the text of the protest. This appeal shall be handed over in writing to the Match Commissioner for further transfer to Directorate. If the text of the protest has not been submitted by the Club upon the expiry of specified time, this protest will not be considered.

63.2.3 Commissioner shall send the text of the protest, report of the Commissioner, reports of Referees to the e-mail address: referee@united-league.com within one (1) hour after the end of Match. Commissioner shall notify the team of the opponent on the protest filed.

63.2.4 The Club filing a protest shall pay a deposit of **one hundred thousand (100,000) RUB** required for the procedure of consideration of this protest by the Directorate. Deposit is transferred by wire transfer to the bank account of the League within two banking days, from the moment of filing a protest. In case of satisfaction of the protest, deposit is returned to the Club.

63.2.5 Delayed protests and protests that have not been recorded in the official scoresheet, as well as protests submitted without payment of the deposit are not accepted for consideration by Directorate.

63.3 Protests during a Play-Off series

63.3.1 For all Matches of Play-off series protest will be accepted and considered by Directorate in the first and the last instances by the Directorate within twelve (12) hours as from the moment of filing the protest.

Decision of Directorate is final and is not subject to appeal and reconsideration.



VTB UNITED LEAGUE REGULATIONS

SEASON 2020-2021

- 63.3.2** Protests during the Play-Off can be taken without prior payment of the fee, but with a guarantee letter on its payment within two banking days from the time of filing of the protest signed by the head and chief accountant of the Club.
- 63.3.3** If the result of the Match is declared invalid, the Match shall be replayed (or finished) on the next day.
- 63.3.4** If the result of the Match is declared invalid and Match cannot be replayed on the next day, decision on the date of replay will be taken by the Directorate.
- 63.4** **Procedure for considering protests**
- 63.4.1** For all Matches of the Regular Championships, protests shall be accepted and considered in the first and the last instances by Directorate within seventy-two (72) hours as from receipt of money (fee) to the League bank account (except for protests filed during the Matches of the Play-off series). Decision of Directorate is final and is not subject to appeal and reconsideration.
- 63.4.2** Club who filed a protest are responsible for the reliability and objectivity of the information contained therein. If the protest contains deliberately false, distorted information, Directorate may impose disciplinary sanctions and/or penalties to the Club.
- 63.4.3** If the result of the Match is invalid, decision on the date of replay (or finishing) will be taken by Directorate.
- 63.4.5** Grounds for refunding the deposit are:
- a) satisfaction of the protest, recognition of circumstances (facts) contained in the protest violating provisions of these Regulations or FIBA Official Basketball Rules;
 - b) if the Club/team withdraws the filed protest in writing or refuses it before the decision is taken by the Directorate.
- The refund of the deposit to the party that filed the protest will be done within three (3) working days from the date of the decision of the Directorate.
- If the protest is not satisfied, deposit will not be refunded.

ARTICLE 64 SANCTIONS IN RELATION OF THE CHAMPIONSHIP

- 64.1** Directorate control compliance with requirements of these Regulations by Players, Coaches, Assistant Coaches, Officials and Team Followers, spectators and other participants of the Championship.
- 64.2** Players, Coaches, Trainers' Assistants, Officials and the Club's Team Followers/team are responsible for observing generally accepted norms and rules of conduct from the moment they arrive on the territory of the sports facilities where the Championship Games are held, and until leaving the sports facilities.
- 64.3** Clubs are responsible for the behavior of spectators and the conduct of the Matches in accordance with the requirements of these Regulations.
- 64.4** Match Commissioner shall take measures to rectify violations of provisions of current FIBA Official Basketball Rules and these Regulations prior and during the Match, If representatives of the Club refuse to rectify violations and/or any of the abovementioned persons (Club, Players, Coaches, Assistant Coaches, Officials and Team Followers, spectators and other participants of the Championship) commit a violation of these Regulations, Match Commissioner shall record information on the violation in Commissioner's report.
- 64.5** Directorate shall take decision on imposing sanctions against Clubs, Players, Coaches, Assistant Coaches, Officials and Team Followers, spectators and other participants of the Championship based on the information provided in the Commissioner's report and provisions of these



VTB UNITED LEAGUE REGULATIONS

SEASON 2020-2021

Regulations. Directorate is also entitled to take decisions on imposing sanctions for violations of these Regulations not specified in the Commissioner's report based, inter alia, on applications of participants of the Championship and other persons by watching photo and/or video recording of Matches, information received from mass and social media and other proof of violation of these Regulations.

Directorate has the right to request written explanation from participants of the Championship with regard to violation of the Regulations in order to take decision.

- 64.6** Club will pay all penalties imposed according to these Regulations on the Club and also for their Players, Coaches, Officials and Team Followers, spectators, other participants of the Championships.
- 64.7** Disqualification (punishment) shall come into force from the date of the next Match. If period of disqualification exceeds number of Matches remaining until the end of this sport season, the remaining period of disqualification will be postponed to the 2021–2022 season of the Championship.
- 64.8** Disqualification in relation to Players, Coaches, Team Followers and other participants of the Championship is individual and suggest the ban for participation in the Championship for a specific person for a specific period in any status irrelevant of transfer from Club to Club, and regardless of the transitions a person from one team to another team within the Club (i.e. he/she is not allowed to play for other team during the period of suspension, and also in other competitions held under the auspices of the RBF).
If a Player, Coach, Team Follower or another participant of the Championship has been disqualified from participating in competitions held under the auspices of the RBF, such person is not entitled to participate in the Championship Matches (i.e., does not have the right to be included in the Technical Entry for the Match) before the expiration of the period of disqualification.
- 64.9** With the aim to confirm recurrence of violations, the violations committed personally by the participant of the Championship since the beginning of sport season will be taken into consideration.
- 64.10** Sanctions for violations committed during the Championship can be imposed by Referees and Directorate according to provisions of FIBA Official Basketball Rules.



VTB UNITED LEAGUE REGULATIONS

SEASON 2020-2021

DISCIPLINARY VIOLATIONS

ARTICLE 65 UNSPORTSMANLIKE BEHAVIOR

65.1 The Club takes responsibility for unsportsmanlike behavior of Players, Coaches, Assistant Coaches and Team followers (disrespectful handling or touching, use of expressions or gestures that offend, wrangling and objection to Referees decision, bad language, provocations expressed verbally, abusive gestures) against Referees, Commissioner, representatives of the League, table officials, opponents, spectators, members of their team before, during, and after Match.

For violation, a fine in the amount of one hundred thousand (100,000) RUB is imposed on the Club.

In case of repeated violation during the season, a fine in the amount of two hundred thousand (200,000) RUB is imposed on the Club, and the Directorate has the right to decide on additional punishment in the form of disqualification of the Player and/or Coach for one (1) game.

In case of violation in the third and every subsequent time during the season – a fine in the amount of two hundred fifty thousand (250,000) RUB is imposed on the Club. Directorate has the right to decide on an additional punishment in the form of disqualification of the Player, Coach, Assistant Coach and/or Team followers for one (1) Match and more.

Note:

- Provisions of this clause 65.1 of Art. 65 of these Regulations will apply only to persons included in the Technical entry for the Match;
- Violation of this clause 65.1 of Art. 65 of these Regulations will be considered repeated if the same Player, Coach, Assistant Coach or Team follower for whose behavior the Club was brought to responsibility for the first time under this article, in the subsequent Match/es of the Championship will admit such a violation.

65.2 Club take responsibility for unsporting behavior of Officials and other persons included in the Team passport of this Club and in the Club questionnaire (during Clubs licensing) (disrespectful treatment or touch, use of expressions or gestures that offend, wrangling and objection to Referees decision, bad language, provocations expressed verbally, abusive gestures) against Referees, Commissioner, League representatives, Table officials, members of the team, opponents, spectators, supporters and other participants of the Match.

For violation, a fine in the amount of two hundred thousand (200,000) RUB will be imposed on the Club.

In case of repeated violation during the season, a fine in the amount of three hundred thousand (300,000) RUB is imposed on the Club. Directorate has the right to decide on additional punishment in the form of disqualification of this person for one (1) Match.

In case of violation in the third and every subsequent time during the season – a fine in the amount of six hundred thousand (600,000) RUB is imposed on the Club. Directorate has the right to decide on an additional punishment in the form of disqualification of this person for one (1) Match and more.

Note:

- Provisions of this clause 65.2 of Art. 65 of these Regulations will apply only to persons included in the Team passport of the Club, not included in the Technical entry for the Match



VTB UNITED LEAGUE REGULATIONS

SEASON 2020-2021

where violation took place and to other persons included in the Club questionnaire during Club licensing;

- Violation of this clause 65.2 of Art. 65 of these Regulations will be considered repeated if the same person for whose behavior the Club was brought to responsibility for the first time under this article, in the subsequent Match/es of the Championship will commit such a violation.

65.3

The Host Club is responsible for unsportsmanlike behavior on those included in the group of supporters, Club mascot, Speaker/announcer, sound operator/DJ of the Host Club (disrespectful treatment or touching, use of expressions or gestures that insult or wrangle) and objection to Referees decision, bad language, provocations expressed verbally, abusive gestures) against Referees, Commissioner, League representatives, Table officials, members of the team, opponents, spectators, supporters and other participants of the Match.

For violation, a fine in the amount of two hundred thousand (200,000) RUB will be imposed on the Club.

In case of repeated violation during the season, a fine in the amount of two hundred fifty thousand (250,000) RUB is imposed on the Club. Directorate has the right to decide on additional punishment in the form of disqualification of this person for one (1) Match.

In case of violation in the third and every subsequent time during the season – a fine in the amount of three hundred thousand (300,000) RUB is imposed on the Club. Directorate has the right to decide on an additional punishment in the form of disqualification of this person for one (1) Match and more.

Note:

- Violation of this clause 65.3 of Art. 65 of these Regulations will be considered repeated if the same person for whose behavior the Club was brought to responsibility for the first time under this article, in the subsequent Match/es of the Championship will commit such a violation.

65.4

The Host Club is responsible for unsportsmanlike behavior of “their spectators/fans” and the Guest Club take responsibility of “their supporters/fans” (abusive shouting, bad language, provocations and aggressive actions by participants of the Match, violation of the rules of conduct in public sites, demonstration of posters, banners, etc. intended to humiliate human dignity against Referees, Match Commissioner, representative of the League, Table officials, participating teams, spectators, supporters and other participants of the Match one (1) hour before, during, and within one (1) hour after the end of the Match.

For violation, a fine in the amount of three hundred thousand (300,000) – five hundred thousand (500,000) RUB is imposed on the Club.

65.5

The Host Club is responsible for rhetoric and/or shouting of “their spectators/fans” and the Guest Club take responsibility for rhetoric and/or shouting of “their supporters/fans” against Referees, Match Commissioner, representative of the League, Table officials, participating teams, spectators, supporters and other participants of the Match intended to humiliate human dignity including but not limited to their religion, race, gender.

For violation, a fine in the amount of three hundred thousand (300,000) – five hundred thousand (500,000) RUB is imposed on the Club.

For repeated violation, a fine in the amount of five hundred thousand (500,000) RUB is imposed on the Club.



VTB UNITED LEAGUE REGULATIONS

SEASON 2020-2021

- 65.6** The Club takes responsibility for unsportsmanlike behavior of their Players, Coaches, Team followers and Officials, other participants of the Championship intended to incite aggressive mood of spectators, supporters and provoking them to hooliganism.
For violation, a fine in the amount of one hundred thousand (100,000) – five hundred thousand (500,000) RUB is imposed on the Club.

ARTICLE 66 THREAT, INTIMIDATION OR AGGRESSIVE BEHAVIOR

- 66.1** The Club takes responsibility for threat, intimidation or aggressive behavior of Players, Coaches, Assistant Coaches and Team followers against Referees, Commissioner, League representatives, Table officials, members of their team, opponents, spectators and other participants of the Match.
For violation, a fine in the amount of five hundred thousand (500,000) RUB is imposed on the Club.

In case of repeated violation during the season, a fine in the amount of seven hundred fifty thousand (750,000) RUB is imposed on the Club. Directorate has the right to decide on additional punishment in the form of disqualification of this person from three (3) to five (5) Matches.

In case of violation in the third and every subsequent time during the season – a fine in the amount of one million (1,000,000) RUB is imposed on the Club. Directorate has the right to decide on additional punishment in the form of disqualification of this person for 1 calendar year.

Note:

- Provisions of this clause 66.1 of Art. 66 of these Regulations will apply only to persons included in the Technical entry for the Match;
- Violation of this clause 66.1 of Art. 66 of these Regulations will be considered repeated if the same person for whose behavior the Club was brought to responsibility for the first time under this article, in the subsequent game/es of the Championship will commit such a violation.

- 66.2** The Club takes responsibility for threat, intimidation or aggressive behavior of their Officials and other persons included in the team passport of the Club as well as in the Club questionnaire under Club licensing against Referees, Commissioner, representatives of the League, Table officials before, during and after the end of the Match.

For violation, a fine in the amount of one million (1,000,000) RUB is imposed on the Club.

In case of repeated violation during the season, a fine in the amount of three million (3,000,000) RUB is imposed on the Club. Directorate has the right to decide on additional punishment in the form of disqualification of this person from three (3) to five (5) Matches.

In case of violation in the third and every subsequent time during the season – a fine in the amount of six million (6,000,000) RUB is imposed on the Club. Directorate has the right to decide on additional punishment in the form of disqualification of this person for 1 calendar year.

Note:

- Provisions of this clause 66.2 of Art. 66 of these Regulations will apply only to persons included in the team passport of the Club not included in the Technical entry for the Match where violation took place and other persons included in the Club questionnaire under Club licensing;



VTB UNITED LEAGUE REGULATIONS

SEASON 2020-2021

- Violation of this clause 66.2 of Art. 66 of these Regulations will be considered repeated if the same person for whose behavior the Club was brought to responsibility for the first time under this article, in the subsequent game/es of the Championship will commit such a violation.

66.3

The Club takes responsibility for threat, intimidation or aggressive behavior of their Officials and other persons included in the team passport of the Club as well as in the Club questionnaire under Club licensing against members of their team and opponent team, spectators, supporters before, during and after the end of the Match.

For violation, a fine in the amount of five hundred thousand (500,000) RUB is imposed on the Club.

In case of repeated violation during the season, a fine in the amount of seven hundred fifty thousand (750,000) RUB is imposed on the Club. Directorate has the right to decide on additional punishment in the form of disqualification of this person from three (3) to five (5) Matches.

In case of violation in the third and every subsequent time during the season – a fine in the amount of one million (1,000,000) RUB is imposed on the Club. Directorate has the right to decide on additional punishment in the form of disqualification of this person for 1 calendar year.

Note:

- Provisions of this clause 66.3 of Art. 66 of these Regulations will apply only to persons included in the team passport of the Club not included in the Technical entry for the Match where violation took place and other persons included in the Club questionnaire under Club licensing;
- Violation of this clause 66.3 of Art. 66 of these Regulations will be considered repeated if the same person for whose behavior the Club was brought to responsibility for the first time under this article, in the subsequent game/es of the Championship will commit such a violation.

66.4

The Host Club takes responsibility for threat, intimidation or aggressive behavior of “their spectator and supporters” and Guest Club take responsibility for threat, intimidation and aggressive behavior of “their spectators and supporters against Referees, Match Commissioner, representatives of the League, Table officials, representatives of participating teams, spectators, and other participants of the Match one hour prior to the Match, during the Match and one hour after the end of the Match.

For violation, a fine in the amount of five hundred thousand (500,000) RUB is imposed on the Club.

In case of repeated violation during the season, a fine in the amount of seven hundred fifty thousand (750,000) RUB is imposed on the Club. Directorate has the right to decide on additional punishment to stage one (1) next Match without spectators.

In case of violation in the third and every subsequent time during the season – a fine in the amount of one million (1,000,000) RUB is imposed on the Club. Directorate has the right to decide on additional punishment to stage next three (3) Matches without spectators.

ARTICLE 67 ACTS OF VIOLENCE

67.1

The Club takes responsibility for acts of violence by Players, Coaches, Assistant Coaches and Team followers against Referees, Commissioner, Representative of the League or Table officials.



VTB UNITED LEAGUE REGULATIONS

SEASON 2020-2021

For violation, a fine in the amount from five hundred thousand (500,000) RUB to one million (1,000,000) RUB is imposed on the Club. Directorate is entitled to take a decision on additional sanction, that is, disqualification of this person for five (5) Matches or more.

Note:

- provisions of this clause 67.1 of Art. 67 of these Regulations will apply only to persons included in the Technical Entry for the Match.

67.2 The Club takes responsibility for acts of violence by Players, Coaches, Assistant Coaches and Team followers against members of their team and opponent team, spectators, supporters and other participants of the Match before, during and after the Match.

For violation, a fine in the amount from three hundred thousand (300,000) RUB to one million (1,000,000) RUB will be imposed on the Club. Directorate is entitled to take a decision on additional sanction, that is, disqualification of this person for one (1) Match or more.

Note:

- provisions of this clause 67.2 of Art. 67 of these Regulations will apply only to persons included in the Technical Entry for the Match.

67.3 The Club takes responsibility for acts of violence by Officials and other persons included in the team passport of the Club and in the questionnaire of the Club under Club licensing against Referees, Commissioner, Representative of the League or Table officials before, during, after the Match.

For violation, a fine in the amount of five million (5,000,000) RUB will be imposed on the Club and Club will play from three (3) to five (5) Matches without spectators.

Note:

- provisions of this clause 67.3 of Art. 67 of these Regulations will apply only to persons included in the team passport of the Club, not included in the Technical entry for the Match where violation was committed as well as to other persons included in the Club questionnaire under Club licensing.

67.4 Acts of violence by Officials and other persons included in the team passport of the Club and in the questionnaire of the Club under Club licensing against members of their team and opponent team, spectators, supporters and other participants of the Match.

For violation, a fine in the amount from five hundred thousand (500,000) RUB to one million (1,000,000) RUB is imposed on the Club. Directorate is entitled to take a decision on additional sanction, that is, disqualification of this person for two (2) Matches or more.

Note:

- provisions of this clause 67.4 of Art. 67 of these Regulations will apply only to persons included in the team passport of the Club, not included in the Technical entry for the Match where violation was committed as well as to other persons included in the Club questionnaire under Club licensing.

67.5 The Host Club takes responsibility for acts of violence of “their spectator and supporters” and Guest Club take responsibility for acts of violence of “their spectators and supporters against Referees, Match Commissioner, representatives of the League, Table officials, representatives of participating teams, spectators, supporters and other participants of the Match one hour prior to the Match, during the Match and one hour after the end of the Match.

For violation, a fine in the amount from five hundred thousand (500,000) RUB to one million (1,000,000) RUB is imposed on the Club and Club will play from three (3) to five (5) home Matches without spectators.



VTB UNITED LEAGUE REGULATIONS

SEASON 2020-2021

ARTICLE 68 GAME LOST BY FORFEIT

- 68.1** If the Club team refuse to play or continue the Match, commit actions impeding to start or re-start the Match after Chief Referee decided to start or re-start it:
- **first violation:** the victory is awarded to a team of opponents with a score of "twenty-zero" (20:0). The team loses the game by “**FORFEIT**”, gets 0 points in the classification, and **a fine in the amount of one million (1,000,000) RUB is imposed on the Club.**
 - **repeated violation:** the team will be **eliminated from the Championship**, results of all Matches played by this team will be annulled (get zero (0) points in the classification).
- If the refusal of the Match results in a delay and/or cancellation of the television broadcast, the Directorate may apply an additional fine on the Club.
- 68.2** In case the Team appears on the playing court with a delay of up to fifteen (15) minutes (except for unforeseen circumstances) – **a fine in the amount of one million (1,000,000) RUB will be imposed on the Club and the Match will start immediately.**
- In the event if a delay of the Match results in a delay and / or cancellation of the television broadcast, the Directorate may apply an additional fine to the Club.
- 68.3** In the event that the Team appears on the playing court with a delay of more than fifteen (15) minutes (except for unforeseen circumstances):
- first violation:** the victory is awarded to a team of opponents with a score of "twenty-zero" (20:0). The team lost the game by “**FORFEIT**”, gets 0 points in the classification, and **a fine in the amount of one million (1,000,000) RUB is imposed.**
 - repeated violation:** The team will be **eliminated from the Championship**, the results of all games played by this Team are annulled (gets zero (0) points in the classification) and **a fine in the amount of two million (2,000,000) RUB is imposed on the Club.**
- In the event if a delay of the Match results in a delay and / or cancellation of the television broadcast, the Directorate may apply an additional fine to the Club.

ARTICLE 69 PARTICIPATION OF A CLUB TEAM MEMBER NOT ENTITLED TO TAKE PART IN THE GAME

- 69.1** In the case of participation in a game of the Player and / or Coach, who do not have the right to participate in the game or who shall have missed the game because of the imposed sanctions, the fine is determined as follows:
- 69.1.1** Victory is awarded to opponents of the team that committed the violation.
 - 69.1.2** In the event that the team that committed the offense lost the game with a difference of more than twenty (20) points, the result remains in effect.
 - 69.1.3** If the game ends with another result, the victory is awarded to a team of opponents with a score of "twenty – zero" (20:0).
 - 69.1.4** In any case, the losing Club team receives 0 (zero) points in the classification and a fine in the amount of one million (1,000,000) RUB will be imposed on the Club.



VTB UNITED LEAGUE REGULATIONS

SEASON 2020-2021

ARTICLE 70 NO-SHOW OF THE CLUB TEAM TO THE CHAMPIONSHIP MATCH

70.1 If the Club team did not show up at the Match (excluding cases provided for in the p. 70.2. of these Regulations) within the timeframe designated by the Directorate, then the following sanctions will be imposed on this Club:

first violation: the victory is awarded to a team of opponents with a score of "twenty-zero" (20:0). The team lost the game by **“FORFEIT”**, gets 0 points in the classification, and **it is fined for one million (1,000,000) RUB.**

repeated violation: The team will be **disqualified from the Championship**, the results of all games played by this Team are annulled (gets zero (0) points) in the classification and **Club is fined for two million (2,000,000) RUB.**

In the event no-show results in a delay and/or cancellation of the television broadcast, the Directorate may apply an additional fine to the Club.

In addition, the Club is obliged to reimburse the Opposing Club (based on the submitted official documents) the costs associated with booking a hotel room, transport, ordering tickets, etc.

70.2 If a Match cannot be held due to restrictive measures affecting holding of sports competitions established by the authorities (e.g. prohibition of sports events, prohibition of entry into the country of the match, quarantine measures upon return from the country of the match/upon entry to the country of the match) introduced at the place of holding of the home match of the host Club (including, in case of transfer of the match to other sports facility in accordance with p. 30.5 of the Regulation), and/or due to shortage of players in the host Club - less than 5 (five) players - as a result of the positive test for COVID-19 and/or the quarantine measures introduced in respect of players related to COVID-19, this shall be recognized as a failure to appear for the match for the host Club and sanctions shall be imposed on it: the host Club loses the game **“FORFEIT OF RIGHT”**, gets 0 (zero) points in the classification. The victory shall be awarded to the rival-team with a score of **“twenty — zero” (20:0).**

If a match cannot be held due to restrictive measures affecting holding of sports competitions established by the authorities (e.g. prohibition of sports events, prohibition of entry into the country of the match, quarantine measures upon return from the country of the match/upon entry to the country of the match) introduced at the place/country of stay/registration of the visiting Club, and/or due to shortage of players in the visiting Club - less than 5 (five) players - as a result of the positive test for COVID-19 and/or the quarantine measures introduced in respect of players related to COVID-19, this shall be recognized as a failure to appear for the match for the visiting Club and sanctions shall be imposed on it: the visiting Club loses the game **“FORFEIT OF RIGHT”**, gets 0 (zero) points in the classification. The victory shall be awarded to the rival team with a score of **“twenty — zero” (20:0).**

ARTICLE 71 REFUSAL OF THE CLUB TO TAKE PART IN THE CHAMPIONSHIP

71.1 If the Club refuses to continue participating in the Championship, then the following sanctions are imposed on this Club:

The club **withdraws from the Championship**, the results of all Matches played by the Team are canceled and a **fine in the amount of ten million (10,000,000) RUB** is imposed on the Club and within five (5) days Club has to return to the League account starting bonus, other premium payments paid by the League to this Club according to these Regulations.



VTB UNITED LEAGUE REGULATIONS

SEASON 2020-2021

ARTICLE 72 SETTLEMENT OF DISPUTES

- 72.1** Any dispute, disagreement or claim with regard to staging and/or participation in the Championship regulated by these Regulations or otherwise resulting from these Regulations shall be solved by arbitration administered by “National Center for Sports Arbitration” (NCSA) under Autonomous Non-Commercial organization “Sports Arbitration Chamber” (ANO SAC) in accordance with provisions of sports arbitration Regulations.
- 72.2** Parties explicitly agree that:
- an expedited arbitration procedure foreseen by Regulations of sports arbitration apply to the dispute among Parties;
 - decision taken by authorized NCSA body on refusal of challenge to arbiter shall not be appealed to the competent court;
 - if the Arbitral Tribunal issues a decision on whether it has competence as a preliminary matter, the Parties are not entitled to submit to the competent court a statement that the Arbitration Tribunal does not have competence.
- 72.3** The decision of Directorate cannot be changed, reversed or challenged except by filing an appeal by the person in respect of whom it was made. Appeals against the decisions of the Directorate (except cl. 63.3.1., 63.4.1 of the Regulations) may be filed exclusively with the “National Center for Sports Arbitration” at ANO “Sports Arbitration Chamber” in accordance with its Regulations. The deadline for filing an appeal is ten working days from the date of sending to the interested party (by email or mail) the appealed decision of the Directorate.
- 72.4** The decision of Directorate remains in force until the decision of the NCSA comes into force.
- 72.5** All disputes, disagreements or claims arising from these Regulations or in connection with it, including those relating to its execution, violation, termination or invalidity, shall be resolved by the “National Center for Sports Arbitration” at ANO “Sports Arbitration Chamber” Regulations.
- 72.6** Championship Basketball Subjects agree to abide by the Statutes, regulations, directives and decisions of the competent authorities of FIBA, FIBA Europe, RBF. Basketball subjects agree to resolve disputes only in the relevant FIBA bodies. Recourse to the courts of general jurisdiction and state arbitration courts is prohibited, unless specifically stipulated by the FIBA regulations.



VTB UNITED LEAGUE REGULATIONS

SEASON 2020-2021

CHAPTER 12

MARKETING REQUIREMENTS FOR THE CHAMPIONSHIP.

OTHER ACTIVITIES.

ARTICLE 73 GENERAL TERMS

- 73.1** The League is the owner of the exclusive rights to use the name of the Championship and its symbols, to advertise goods, works and services in the venues of the Championship Matches. The League has the right to fully or partially delegate its rights to third parties.
- 73.2.** Clubs may use part of the rights to advertise goods, works and services in the venues of the Championship Matches, including for commercial purposes, in the manner and under the conditions provided for in these Regulations.
- 73.3** Placement of advertising information by the Clubs at the Championship Matches held in the territory of the Russian Federation is carried out in accordance with requirements of legislation of the Russian Federation.
Placement of advertising information at Championship Matches held outside the territory of the Russian Federation is carried out in accordance with requirements of legislation of the countries of Foreign Clubs.
For violation, a fine in the amount of five hundred thousand (500,000) RUB is imposed on the Club for each Match.
- 73.4** Advertising information displayed by Clubs at Championship Matches shall contain no more than 3 of 5 designated components:
- Company name;
 - Trademark;
 - One noun describing product, services;
 - Visual image demonstrating product or service;
 - Slogan (for example, Panasonic. Ideas for life) if it is part of the trademark.
- 73.5** Advertising constructions placed inside sports facility, venue of the Championship Match, should meet the following requirements:
- shall comply with safety regulations;
 - shall not interfere with the movement of Match participants and spectators;
 - shall not interfere with the conduct of the Match, players, coaches, referees, referees, television broadcast operators, and do not block the review of the fans.



VTB UNITED LEAGUE REGULATIONS

SEASON 2020-2021

ARTICLE 74 RIGHTS OF THE LEAGUE

74.1 The League, as the organizer of the Championship and the owner of all property and non-property rights to the Championship, has the following rights, including, but not limited to:

- attract sponsors (partners, advertisers), as well as reserve any product categories in order to ensure the exclusivity of attracted sponsors (partners, advertisers) of the League in their product categories. To ensure this provision, the League coordinates product categories, locations and the appearance of promotional materials from sponsors (partners, advertisers) of Clubs during the Championship Matches and reserves the right to refuse to approve sponsors (partners, advertisers) of the Club in conflict with product categories reserved for the League;
- use any advertising opportunities of sports facilities during the Championship Matches, sports facilities equipment and carry out any advertising campaigns, promotions, marketing activities during the Championship Matches and other League events;
- assign official statuses and titles for sponsors (partners, advertisers) of the League;
- use and transfer the rights to use television and radio broadcasts, broadcasts on the Internet, broadcasts via mobile communication channels and photography of Championship Matches and other League events in the territory of any country of the world;
- use for any purpose names and symbols of the Championship;
- use names, logos and registered trademarks/signs of the Clubs, images of Players in the equipment of the Championship Participant Clubs in order to popularize the League and Championship and promote events organized by the League (in particular, but not limited to, the All-Star Game), including for commercial purposes.
- to produce informational and promotional materials, as well as to produce souvenirs using the names, logos and trademarks of Clubs, images of Players in the equipment of the Championship Participant Clubs. The design of such souvenirs must be agreed upon in writing (by e-mail) with the participating Clubs. At the same time, the participating Club does not have the right to unreasonably refuse such agreement;
- use TV, video and photo materials of Championship matches that reflect League games and other events held by the League, in their entirety and separately, including images of Players. At the same time, this right does not cancel rights. Clubs have the right to use such materials in the manner and on the conditions provided for by these Regulations in relation to their home matches.
- transfer to the League's sponsors/advertisers the rights to use photos and videos taken at Championship Matches and other League events to promote and advertise the sponsor/advertiser's brand or products.
- this includes the right to use photos and videos of game moments from Matches in advertising materials (group images, without focusing on one of the participants). It is



VTB UNITED LEAGUE REGULATIONS

SEASON 2020-2021

allowed to edit photos and videos by clipping, adding text, combining photos, and creating collages. It is not allowed to make changes to the image or video that radically change the context of the source material (for example, changing the form, intentionally distorting or changing the numbers, names of Players, changing the image of the Club's sponsors on the playing uniform to the League's sponsors);

- this does not include the right to use for advertising purposes images of specific Players, Coaches and other participants of Matches received outside of Championship Matches, personification of advertising messages (creating the effect that the advertised product or brand is recommended personally by a specific Player, Coach or other participant of the Match) and additionally requires the involvement of these persons in negotiations and the conclusion of personal contracts for the use of the image.

ARTICLE 75 RIGHTS OF THE CLUBS

75.1 Clubs have the following rights:

- Use part of the rights in relation of the League Championship, including commercial purposes, in the manner and under the conditions provided for by the Regulations, namely, taking into account the interests of the League and its sponsors (partners, advertisers);
- Use rights to explore advertising capacity of sports facilities, venues of the Championship Matches, in the order and on conditions specified by the Regulations taking into account interests of the League and sponsors (partners, advertisers), organize advertising campaigns, marketing events during home Matches of the Championship for their own purposes including commercial;
- Use rights to explore advertising capacity of Players equipment in the order and on conditions specified by the Regulations taking into account interests of the League and sponsors (partners, advertisers);
- Receive revenues from sale of season and other subscriptions and tickets for home Matches of the Championship;
- Receive information on sponsors (partners, advertisers) of the League in the scope determined by the League, required to fulfil obligations in compliance with agreements among sponsors and the League and also to exclude violations of the League rights in goods categories reserved for the League;
- Conclude agreements with sponsors (partners, advertisers) of the Club aimed at realization of the Club rights for advertising capacity provided to Clubs by these Regulations;
- Use logos and names of other Clubs participating in the Championships for informational purposes during staging and promotion of the Championship Matches.

ARTICLE 76 CLUBS MARKETING OBLIGATIONS

76.1 The Club shall:

- in case of changes in the list of sponsors (partners, advertisers) of the Club for the 2020–2021 season provided under licensing, send the amended list to the League no later than three (3) calendar days after such changes;



VTB UNITED LEAGUE REGULATIONS

SEASON 2020-2021

- send the modified playing and/or warm-up uniform layouts to the League for approval by the League;
- during each home Championship match, ensure, at its own expense and on its own, in strict accordance with the requirements of these Regulations, proper placement of promotional materials and information provided by the League about sponsors (partners, advertisers) of the League: in sports facilities where Championship Matches are held, including, but not limited to, on the external facade, in the lobby, on the playing court, in the stands for spectators; on printed products issued for the Championship Matches; on the equipment of the Championship Match participants; on the official website of the Club;
- during each home Championship Match, use an automated access control system for spectators at all entrances to the sports facility;
- to ensure the sale of tickets to the Championship Match via an electronic ticket system via the Internet (for all sports facilities where the Host Club conducts "home" Matches).
- to prevent the placement of any audio, video, printed and other promotional materials and information in conflict with product categories reserved for the League inside sports facilities;
- to ensure participation of Players, Coaches, Team followers and Officials of the Club in events held for sponsors (partners, advertisers) of the League no more than three (3) times per Championship upon prior agreement with the Club at least two (2) weeks before such an event;
- to ensure participation of the Players and Coaches of the Club's teams in photo and video recordings and other events organized by the League, no more than three (3) times per Championship by prior agreement with the Club at least two (2) weeks before such an event.

76.2 Based on the League written request sent to the Club by e-mail at least four (4) calendar days prior to the Match date, the Host Club shall provide the League:

76.2.1 At least thirty-five (35) VIP tickets (of which at least 4 tickets for seats located in the central sector of the tribune located at the level of the playing area, or VIP Lodge, at least 16 entrance tickets – in the side sector of the tribune located on the level of the playing court, or in the central sector of the stand with the provided hospitality program (meals), and sixty (60) standard entrance tickets.

In case of violation (refusal to provide required quota or providing tickets of a lower category, a fine will be imposed on the Club in the amount of one hundred thousand (100,000) RUB.

76.2.2 At least ten (10) one-day passes with a right to park vehicles near the sports facility, where Matches of the Championship take place;

76.3 Based on the League written request sent to the Club by e-mail at least fourteen (14) calendar days prior to the Match date, the Host Club shall provide the League at least ten (10) permanent passes with a right to park vehicles near sports facility, where Matches of the Championship take place.

76.4 Based on the League preliminary request, Host Club must a discount of at least 15% of the ticket cost for not more than fifty (50) tickets for all categories of tickets available in the sports facility where the Match will take place except for VIP tickets.

ARTICLE 77 TRADE CATEGORIES RESERVED BY THE LEAGUE

77.1 With the aim to secure exclusivity of sponsors (partners, advertisers) of the League, trade categories reserved for the League for season 2020–2021 are the following:

- insurance, insurance services, brokers and accompanying insurance services;
- official ball;
- diamond mining companies and manufacturers of jewelry with diamonds;



VTB UNITED LEAGUE REGULATIONS

SEASON 2020-2021

- sport equipment of Referees and Table officials.

The League reserves the right to make amendments to Article 77 of the Regulations during the season if new sponsorship agreements signed.

Clubs guarantee exclusivity compliance in the sponsors' trade categories assigned to the League and in this relation take the obligation prevent from displaying advertising materials and information of sponsors (partners, advertisers) of the Club or other third parties, identical to trade categories reserved by the League, at Championship Matches including any advertising structure in the sports facility, Players equipment.

For violation, a fine in the amount of one million (1,000,000) RUB will be imposed on the Club.

In case of repeated violation, a fine in the amount of one million five hundred thousand (1,500,000) RUB will be imposed on the Club.

In case of the third and any subsequent violation, a fine of two million (2,000,000) – five million (5,000,000) RUB will be imposed on the Club by decision of Directorate.

ARTICLE 78 TICKETING PROGRAM AND SYSTEM OF ACCESS CONTROL. CONTROL OF THE ATTENDANCE OF THE CHAMPIONSHIP MATCHES

78.1 Ticketing program and system of access control of each Host Club should meet the following minimum requirements:

- issue of electronic tickets with the name of the buyer;
- sale of electronic tickets through the official website of the Club;
- use of a promotional code for discounts when purchasing tickets through the official Club website;
- return of electronic tickets;
- adding images (for example, logos of sponsors) in an electronic ticket;
- integration / unloading of the ticket system data through the API (for example, for data exchange with the CRM system);
- uploading data in tabular format (CSV or Excel) indicating for each ticket and subscription for a particular match:
 - barcode;
 - time of sale;
 - ticket price (including zero);
 - time of SAC operation.
- access to SAC data on number of pass-through in real time;
- access towards statistics available at Club representative on pass-through;
- period of receipt of the unloading of data on tickets and passes to the arena for no more than one (1) business day after the end of the Match;
- ensure stable operation of the system under high loads (for example, during peak times of passes to a sports facility);
- number of turnstiles or manual scanners at least two for each entry;



VTB UNITED LEAGUE REGULATIONS

SEASON 2020-2021

- providing scanning of tickets of all categories (including for spectators of boxes, VIP seats).

78.2 Clubs shall provide the League with access to data of electronic ticket systems installed in sports facilities for the purpose of selling tickets and to ensure connection to the League's information gateway to exchange information on the actual attendance of matches (the number of SAC actions), the number of tickets sold and subscriptions, and the issuance of invitations. Other information may be provided by the Clubs at their discretion in the framework of cooperation with the League to form a single ticket module.

If the Club does not have an electronic ticket system with the possibility of remote sale of tickets and SAC, **a fine in the amount of three hundred thousand (300,000) RUB may be imposed on the Club by decision of the Directorate.**

In case the Club did not provide a technical opportunity to receive information through a gateway organized by the League, or a similar opportunity to receive verified information on the number of tickets sold, attendance and invitation tickets, Club will not receive Premium remuneration in terms of "Marketing" indicator.

78.3 Clubs must send to the League no later than the 5th day of each month in writing, signed by the head of the Club, reports on attendance and tickets sold to the Club's home matches for the previous month (in the form provided by the League).

The data in the report shall match data from the ticket system upload. Reports that do not match the data uploaded from the ticket system are considered invalid.

For violation of the Club, a fine of thirty thousand (30,000) RUB is imposed.

78.4 Control of the information specified in the monthly reports of the Clubs is maintained by using data obtained from the Clubs' electronic ticketing systems. Written reports of the Clubs are the basis for the distribution of Premium remuneration in terms of "Marketing" indicator.

The League has the right to request unloading from the ticket system of the Club for any Championship Match. This unloading should contain information on each issued ticket and on each subscription to the Match:

- date of sale;
- price;
- barcode;
- time of pass (if ticket or subscription were not used, there is no pass time).

The League also has the right to request accounting statements for tickets sold and season tickets. The report is verified (checked and confirmed) by the League on the basis of discharge from the ticket system, as well as additionally through photo or video reports, screenshots from the ticket system, as well as through the League information gateway.

If the Club provides incorrect information (data) on tickets / subscriptions or manipulates electronic ticket systems in order to improve the Club's performance in order to receive Bonus remuneration according to the "Marketing" indicator, the League will become aware of this, the Club loses the



VTB UNITED LEAGUE REGULATIONS

SEASON 2020-2021

right to participate in the distribution of Bonus remuneration according to the “Marketing” indicator and the Club, **a fine in the amount of five hundred thousand (500,000) RUB is imposed.**

78.5 The League information gateway can be used to form a ticket module that will be placed on official League Internet resources, a mobile application, etc. The League discusses the conditions and rules for selling tickets through the ticket module with Clubs and ticket operators of Clubs.

The League may also place a link to the resource or widget of the ticket partner (operator, agent) of the Club on the official Internet resources of the League, in the mobile application, on social networks. The terms and conditions for the sale of tickets in this way are discussed by the League with the Clubs and the ticket partner of the Clubs.

78.6 The club must use a CRM system (Customer Relationship Management System) that meets the following minimum requirements:

- ability to create clients in automatic or manual mode with information about them;
- ability to associate actions (buying tickets, paraphernalia and other club goods) with specific customers;
- ability to keep track of the history of communication, conduct communication with customers through the CRM system, compile and segment customer lists.

A club that does not yet use the CRM system should start using it by June 15, 2021 and inform the League of it in writing.

78.7 The club is obliged to ensure at its own expense the participation of at least one (1) employee responsible for the marketing direction, at least one (1) time per year in marketing meetings (VTB UL Development Meetup) organized by the League.

ARTICLE 79 PLAYING COURT

79.1 Before the start of the Championship, the League shall send the Clubs a scheme for placing promotional materials at the playing court, taking into account the League's sponsorship obligations:

- League logo in the center circle;
- two logos of the League's Title sponsor, VTB Bank, are on the left and right of the Central circle;
- four logos of the League's sponsors along each sideline;
- two 3D logos of the League's sponsor behind the front lines in front of the side LED screens; The Clubs have the right to place on the playing court:
- two logos of the Club's sponsor in two semicircles in the free throw zone;
- two 2D logos of the Club sponsor(s) behind the front lines.

The layout of advertising materials on the playing court is specified in Annex 8 to the Regulations. The club must, no later than thirty (30) calendar days before the start of the Championship, develop a layout of the playing field indicating sponsors (partners, advertisers) of the League and sponsors (partners, advertisers) of the Club and send it to the League for approval in pdf format (in color).



VTB UNITED LEAGUE REGULATIONS

SEASON 2020-2021

The layout is developed by the Club on the basis of the layout of advertising materials at the playing court (Annex No. 8 to the Regulations).

The League establishes the compliance of the layout of the playing court with the requirements of these Regulations. The League reserves the right to refuse to approve the layout if there are sponsors (partners, advertisers) of the Club on the layout who violate the League's rights in product categories reserved for the League.

If the layouts meet the requirements of the Regulations and the sponsors placed on them (partners, advertisers) of the Club do not violate the League's rights in product categories reserved for the League, an information letter confirming the layout of the playing court is sent to the Club.

If the playing court layouts do not meet the requirements of the Regulations and/or if the sponsors (partners, advertisers) placed on them violate the League's rights in product categories reserved for the League, an information letter shall be sent to the Club indicating the necessary changes. The club must, within 3 days, make changes to the layout and send to the League for re-approval the layout of the playing court.

For violation, a fine in the amount of three hundred thousand (300,000) RUB will be imposed on the Club.

79.2 During the season, the layout of the playing court may be changed solely due to a change of sponsor (partner, advertiser) of the Club or the League.

The Club shall send to the League modified layouts of the playing court for approval by the League no later than seven (7) calendar days before the date of the Match in which the Club plans to make changes.

The procedure for approving a modified layout of the playing court is identical to that specified in clause 79.2 of art. 79 of these Regulations.

For violation, a fine in the amount of three hundred thousand (300,000) RUB will be imposed on the Club.

79.3 The League shall produce at its own expense and submit to the Clubs before the start of the season sponsors' promotional materials (partners, advertisers) of the League, which should be placed on the playing court by and at the expense of the Clubs in strict accordance with the League-approved layout of the playing court. In addition, the Club, at its own expense and on its own, produces and places name of the city in which the sports facility is located, as indicated in the layout of the playing court approved by the League.

In case of placing advertisements in semicircles, in the zone of free throws, advertising must be the same content in both semicircles, and the marking lines of the playing court of the zones must be clearly visible. It is prohibited to place advertisements or other information at the playing court outside the zones specified in Annex No. 8 to these Regulations.



VTB UNITED LEAGUE REGULATIONS

SEASON 2020-2021

For each fact of improper placement of promotional materials at the playing court, a fine in the amount of three hundred thousand (300,000) RUB will be imposed on the Club.

In case of a second violation during the season, a fine in the amount of three hundred fifty thousand (350,000) RUB will be imposed on the Club.

In the event of a violation for the third and subsequent times during the season, a fine in the amount of six hundred thousand (600,000) RUB to one million five hundred thousand (1,500,000) RUB will be imposed on the Club.

79.4

Advertising surfaces at playing court, specified in Annex No. 8 as “League sponsor” are reserved exclusively for the implementation of the League sponsorship agreements. Advertising surfaces specified in Annex No. 8 as the “Club Sponsor” are reserved exclusively for the implementation of the Club sponsorship agreements.

At Matches held in the territory of the Russian Federation and the Republic of Kazakhstan, it is prohibited to place advertisement for the sponsor or partner of the Club, whose activity is to organize and conduct gambling in bookmakers, sweepstakes, slot machine halls, casinos, as well as being an operator of lotteries, Forex dealers, on the playing court.

For violation, a fine in the amount of one million (1,000,000) RUB is imposed on the Club.

In case of a repeated violation, a fine in the amount of One million five hundred thousand (1,500,000) RUB is imposed on the Club.

In the case of third and subsequent violations, a fine in the amount from two million (2,000,000) rubles to five million (5,000,000) RUB is imposed on the Club by the decision of the Directorate.

ARTICLE 80 LED SCREEN

80.1 The Host Club shall place advertising LED constructions along the perimeter of the playing court (LED screen) meeting the following requirements:

- LED screen shall consist of five (5) sections. Scheme of placement of LED screen is specified in Annex 8 to these Regulations;
- Height of LED screen is from 80 to 90 cm;
- Length of the LED screen sections shall meet the following requirements: at least six (6) to the front lines, from six (6) to seven (7) meters in front of substitutes benches, from twelve (12) to fourteen (14) meters in front of Referees table (central LED screen);
- Distance between the side and the central LED shall be from two (2) to three (3) meters.

Mascots, cheerleaders, photographers, animators, etc. should not be in the area in front of advertising construction along the playing court.

Quantity and scope of advertising should not influence on the quality of TV picture and safety of the Match.



VTB UNITED LEAGUE REGULATIONS

SEASON 2020-2021

Clubs shall send the League technical parameters (physical dimensions of sections and LED resolution) by official letter at least thirty (30) calendar days prior to the Championship.

For violation, a fine in the amount of two hundred thousand (200,000) RUB will be imposed on the Club.

80.2

Only advertising clip of the League Title sponsor, PC VTB Bank shall be demonstrated on the central LED screen (in front of Referees table) (at least 50% of advertising time) and image promos of the League. League shall produce at their expense advertising promos of the Title sponsor and image spots of the League and send them to the Club for demonstration on the central LED screen. It is allowed to demonstrate promos of the Club General sponsors provided that Club submitted their application in writing to the League at least ten (10) calendar days prior to the Championship and explained the reason to demonstrate promos of the Club General sponsors. In this case, advertising time on the LED screen central section provided to Club by the League at the expense of image promos shall not exceed 25% of the total advertising time.

The League reserves the right to refuse the Club to broadcast commercials of the General Sponsors if the broadcasting of commercials of the General Sponsors of the Club violates the rights of the League in the product categories reserved for the League.

For violation of the Club, a fine of three hundred thousand (300,000) RUB is imposed.

In the case of a second violation during the season, the Club is fined three hundred fifty thousand (350,000) RUB.

In the event of a violation for the third and subsequent times during the season, the Club is fined from six hundred thousand (600,000) RUB to one million five hundred thousand (1,500,000) RUB.

80.3

Advertising promos of the League, sponsors and partners of the League, as well as sponsors and partners of the Clubs according to the list of promos indicating timing and titles of sponsors approved League shall be demonstrated on LED screens in front of the front line and substitutes benches (side LED screens). Promos of sponsors and partners of the League should take at least 50% of the Match time compared to all demonstrated promos and be equally distributed among the quarters. Minimum number of demonstrations of each League sponsor's and partner's promo should be fifteen (15) times per Match, when the kick-off of the Match starts with throwing of the ball and ends with the signal (0:00.0) of game clock and main clock. Each promo of the League sponsor should be demonstrated in full without interruption by any spots. Advertising promos of the League sponsors and partners should be demonstrated sixty (60) minutes prior to the Match. League shall produce at their expense advertising promos of the League sponsors and partners and send them to the Club for demonstration on the side LED screen.

For violation, a fine of three hundred thousand (300,000) RUB is imposed on the Club.

In the case of a second violation during the season, the Club is fined three hundred fifty thousand (350,000) RUB.



VTB UNITED LEAGUE REGULATIONS

SEASON 2020-2021

In the event of a violation for the third and subsequent times during the season, the Club is fined from six hundred thousand (600,000) RUB to one million five hundred thousand (1,500,000) RUB.

80.4

Club shall send to the League for their approval the list of promos to be demonstrated on central and side LED screens indicating timing and title of sponsors at least fifteen (15) calendar days prior to the Championship.

List of promos shall be prepared in consideration of the list of League's promos.

The League reserves the right to refuse the Club to broadcast commercials of sponsors if the broadcasting of commercials of the Club sponsors is in conflict with the rights of the League in the product categories reserved for the League.

Promos demonstrated by the Club on the central and side LED screens at the Championship Matches should be compliant to the list of promos and their timing and titles of sponsors approved by the League.

If changes of the approved list of promos is required during the season, Club has to agree upon a new list of promos not later than seven (7) calendar days prior to the Match where they plan to demonstrate new promos.

For violation, a fine of three hundred thousand (300,000) RUB is imposed on the Club.

In the case of a second violation during the season, the Club is fined three hundred fifty thousand (350,000) RUB.

In the event of a violation for the third and subsequent times during the season, the Club is fined from six hundred thousand (600,000) RUB to one million five hundred thousand (1,500,000) RUB.

ARTICLE 81 VIDEO SCREENS AND VIDEO CUBE

81.1

Advertising promos of the League's sponsors (partners, advertisers) as well as Club sponsors (partners, advertisers) shall be demonstrated on video screens and media cube in accordance with the list of video promos indicating timing and title of sponsors approved by the League.

Advertising promos of the League sponsors (partners, advertisers) shall be demonstrated at least four (4) times per Match: before the Match, during interval and the third quarter.

Club shall send to the League for their approval the list of promos to be demonstrated on video screen and video cube indicating timing and title of sponsors at least fifteen (15) calendar days prior to the Championship.

List of promos shall be prepared in consideration of the list of League's promos.

The League reserves the right to refuse the Club to broadcast video commercials of the Club sponsors on video screen and video cube if this demonstration is in conflict with the rights of the League in the product categories reserved for the League.

If changes of the approved list of promos is required during the season, Club has to agree upon a new list of video promos not later than seven (7) calendar days prior to the Match where they plan



VTB UNITED LEAGUE REGULATIONS

SEASON 2020-2021

to demonstrate new promos. League shall produce advertising video promos of sponsors (partners, advertisers) of the League at their expense and send them to the Club for demonstration on video screens and video cube.

For violation, a fine of three hundred thousand (300,000) RUB is imposed on the Club.

In the case of a second violation during the season, the Club is fined three hundred fifty thousand (350,000) RUB.

In the event of a violation for the third and subsequent times during the season, the Club is fined from six hundred thousand (600,000) RUB to one million five hundred thousand (1,500,000) RUB.

ARTICLE 82 EQUIPMENT OF CHAMPIONSHIP PARTICIPANTS

82.1 Rules of advertising display on equipment of Championship participants are regulated by Chapter 4 of these Regulations.

ARTICLE 83 HOOPS, BACKBOARDS, BACKBOARD SUPPORT STRUCTURES

83.1 The Host Club shall place stickers submitted by the League on the backboard and locking fixing the hoop and backboard support:

- On the front side of backboard in the right bottom corner;
- On the front side of backboard in the right upper corner;
- On the front side of backboard in the left upper corner
- On the ring.

Placement of advertising materials should correspond to the scheme specified in the Annex No. 8 to these Regulations.

The League shall produce stickers of sponsors (partners, advertisers of the League) and the League logo at their expense and hand them over to the Club for placement.

For violation, a fine of three hundred thousand (300,000) RUB is imposed on the Club.

In the case of a second violation during the season, the Club is fined three hundred fifty thousand (350,000) RUB.

In the event of a violation for the third and subsequent times during the season, the Club is fined from six hundred thousand (600,000) RUB to one million five hundred thousand (1,500,000) RUB.

83.2 Name, trademark of the Club sponsors (partners, advertisers) or logo of the manufacturer can be placed to:

- on the backboard support;
- on the padding of the backboard support;
- above the backboard support;
- above the backboard below the shot clock displays;
- on the front side of the backboard, in the lower left corner (no more than 23 cm in height);



VTB UNITED LEAGUE REGULATIONS

SEASON 2020-2021

- it is allowed to place a logo of international competitions in which the Host Club participates, or the logo of the Club's sponsor on the front side of the backboard in the lower left corner. Placement of advertising materials shall comply with the layout specified in Annex 8 to these Regulations.

For violation, a fine of three hundred thousand (300,000) RUB is imposed on the Club.

ARTICLE 84 BANNERS FOR INTERVIEW (PRESS WALL)

- 84.1** The Club shall produce banners for interview (press wall) at their expense and place League's and sponsors (partners, advertisers) logos in accordance with templates approved by the League.

Use of press walls not meeting the requirements of templates approved by the League at Championship Matches is prohibited.

For violation, a fine of three hundred thousand (300,000) RUB is imposed on the Club.

In the case of a second violation during the season, the Club is fined three hundred fifty thousand (350,000) RUB.

In the event of a violation for the third and subsequent times during the season, the Club is fined from six hundred thousand (600,000) RUB to one million five hundred thousand (1,500,000) RUB.

- 84.2** Placement of logos at the press wall for interview shall be compulsory approved by the League. Club shall send actual dimensions of press walls (in the press conference room and mixed zone) to the League at least thirty (30) calendar days prior to the Championships, and based on these dimensions, League will send the Club templates of press walls with logos of the League, their sponsors (partners, advertisers) and areas for placement of Club sponsors (partners, advertisers). Club shall send the League templates of press walls with placed logos of the Club sponsors (partners, advertisers) in the pdf format in color for their approval at least fifteen (15) calendar days prior to the Championship.

The League reserves the right to refuse the Club approval of the press walls templates if the Club sponsors (partners, advertisers) logos infringe rights of the League in the categories of goods reserved by the League.

For violation, a fine of one hundred thousand (100,000) RUB is imposed on the Club.

In the case of a second violation during the season, the Club is fined one hundred fifty thousand (150,000) RUB.

In the event of a violation for the third and subsequent times during the season, the Club is fined from two hundred thousand (200,000) RUB to five hundred thousand (500,000) RUB.

- 84.3** If changes to the templates of press – walls approved by the League are required (adding or excluding the Club sponsor), Club take responsibility to agree new templates with the League at least seven (7) calendar days prior to the Match where they plan to use amended press walls.

- 84.4** The Host Club shall send to the League e-mail address: marketing@united-league.com photos of the coaches of the Host and the Guest Clubs against the press wall at the post-Match press conference (at least, 1 photo of each Coach) not later than 12.00 (Moscow time) on the next day after the home Match.



VTB UNITED LEAGUE REGULATIONS

SEASON 2020-2021

ARTICLE 85 PRINTED MATERIALS

85.1 Host Club is obliged to place logos of the League and the League sponsors (partners, advertisers) in accordance with templates approved by the League on every printed product (tickets, e-tickets, programs, placards, banners, posters, invitations, etc.) issued for the Championship Matches. Use of printed materials inconsistent with templates approved by the League at the Championship Matches is prohibited.

For violation, a fine of three hundred thousand (300,000) RUB is imposed on the Club.

In the case of a second violation during the season, the Club is fined three hundred fifty thousand (350,000) RUB.

In the event of a violation for the third and subsequent times during the season, the Club is fined from six hundred thousand (600,000) RUB to one million five hundred thousand (1,500,000) RUB.

85.2 The Host Club shall send the League the list of printed materials to be issued for the Championships Matches as well as their templates in the pdf format in color for their approval at least thirty (30) calendar days prior to the Championship Matches.

The League reserves the right to refuse the Club approval of the templates of printed materials if the Club sponsors (partners, advertisers) logos infringe rights of the League in the categories of goods reserved by the League.

If changes to the templates of printed materials approved by the League are required (adding or excluding the Club sponsor), Club take responsibility to agree new templates with the League at least seven (7) calendar days prior to the Match where they plan to use amended printed materials.

For violation, a fine of one hundred thousand (100,000) RUB is imposed on the Club.

In the case of a second violation during the season, the Club is fined one hundred fifty thousand (150,000) RUB.

In the event of a violation for the third and subsequent times during the season, the Club is fined from two hundred thousand (200,000) RUB to five hundred thousand (500,000) RUB.

ARTICLE 86 OFFICIAL WEBSITES OF THE LEAGUE AND CLUBS

86.1 Clubs ensure placement of banner advertising links to the official website of the League using UTM markers, provided by the League on every page of the official website. League will develop and send banners.

86.2 Clubs ensure placement of textual and graphic link to the League internet-shop using UTM markers provided by the League on every page of the Clubs official website. This link should be placed at the main top-tier of menu of the official Clubs websites.

86.3 Clubs official websites should have web counter for every page via analytical systems Yandex Metrics/Google Analytics or similar ones. Club shall submit uploading according to requested parameters on demand of the League.

86.4 Clubs Official websites should have a section containing information on Clubs tickets sale. System of tickets sale on Clubs official websites should be integrated with analytical systems: Yandex Metrics (electronic commerce)/Google Analytics (Enhanced e-commerce) or similar ones.



VTB UNITED LEAGUE REGULATIONS

SEASON 2020-2021

ARTICLE 87 OUTDOOR ADVERTISING

87.1 The Host Club takes responsibility to place logos of the League and League sponsors (partners, advertisers) in accordance with templates approved by the League at the outdoor advertising of the Championship Matches (banners, backboards, street banners, electronic screens, etc. Use of outdoor advertising not meeting the requirements of templates approved by the League is prohibited.

For violation, a fine in the amount of three hundred thousand (300,000) RUB will be imposed on the Club.

87.2 Club has to send the League template of static advertising in the pdf format in color or video promo of this advertising with logos of the League and League sponsors (partners, advertisers) for their approval at least seven (7) days prior to the Championship Match for which outdoor advertising will be arranged. League reserve the right to refuse the approval of the template or video promo if logos of Club sponsors (partners, advertisers) infringing rights of the League in the categories of goods reserved by the League are placed there.

For violation, a fine in the amount of three hundred thousand (300,000) RUB will be imposed on the Club.

ARTICLE 88 FLAG BEARING AND AUDIO CLIPS

88.1 Prior to each Match of the Championship a flag with the League logo shall be brought to the central circle of the playing court. Host Club has to arrange broadcast of the audio clip during flag bearing using sound amplifying equipment of the sports facility.

The League shall produce audio clip and flag at their own expense and send them to Clubs prior to the Championship. If the flag of the League was lost or damaged due to Club's fault, Club shall produce the flag at their expense according to the template provided by the League.

For violation, a fine of one hundred thousand (100,000) RUB is imposed on the Club.

In the case of a second violation during the season, the Club is fined one hundred fifty thousand (150,000) RUB.

In the event of a violation for the third and subsequent times during the season, the Club is fined from two hundred thousand (200,000) RUB to five hundred thousand (500,000) RUB.

88.2 Text of the announcer and/or advertising audio clips provided by the League shall be broadcasted in the intervals between the quarters of the Match using the sound amplifying equipment of the sports facility. Change of audio clips and text of the announcer shall be done on the first demand of the League but in any case, not later than two (2) working days as from receipt of the written notification by e-mail.

For violation, a fine of one hundred thousand (100,000) RUB is imposed on the Club.



VTB UNITED LEAGUE REGULATIONS

SEASON 2020-2021

In the case of a second violation during the season, the Club is fined one hundred fifty thousand (150,000) RUB.

In the event of a violation for the third and subsequent times during the season, the Club is fined from two hundred thousand (200,000) RUB to five hundred thousand (500,000) RUB.

ARTICLE 89 ADDITIONAL PROVISIONS

- 89.1** Advertising placed on souvenir or other products with logo of the League, produced by Clubs shall be mandatorily agreed with the League.
- 89.2** Placement of advertising on benches for substitutes is allowed, however, Club shall mandatorily agree it with the League.
- 89.3** On demand of the League, Clubs shall provide the League and its sponsors (partners, advertisers) with space in the lobby of sports facilities for holding of any activities, promo actions, marketing and other events.
- 89.4** It is allowed to place advertising on supporting and other structures inside sports facility if it does not infringe exclusivity of the goods categories of the League sponsors and quality of the event.
- 89.5** At Matches held in the territory of the Russian Federation and the Republic of Kazakhstan, it is prohibited to place advertisement for the sponsor or partner of the Club, whose activity is to organize and conduct gambling in bookmakers, sweepstakes, slot machine halls, casinos, as well as being an operator of lotteries, Forex dealers, on any advertising surfaces:
- on the playing court;
 - in the team bench area;
 - on the referees' table;
 - behind the team benches and the referees' table in the field of view of the leading TV camera during the TV broadcast.
- For violation, a fine in the amount of one million (1,000,000) RUB is imposed on the Club. In case of a repeated violation, a fine in the amount of One million five hundred thousand (1,500,000) RUB is imposed on the Club. In the case of third and subsequent violations, a fine in the amount from two million (2,000,000) rubles to five million (5,000,000) RUB is imposed on the Club by the decision of the Directorate.**
- 89.6** At all Matches, it is allowed to place advertisement for the sponsor or partner of the Club, whose activity is to organize and conduct gambling in bookmakers, sweepstakes, slot machine halls, casinos, as well as being an operator of lotteries, Forex dealers, on the following advertising surfaces:
- on the playing and warm-up uniform;
 - on LED screens;
 - on backboards and backboard supports;
 - on other surfaces not specified in paragraph 89.5 of article 89 of the Regulations, where advertising by such sponsor or partner of the Club is permitted by applicable law.
- 89.7.** Advertising of other sports leagues, with the exception of the League, any hidden advertising on Players' equipment, including on additional players' equipment is prohibited.
- 89.8.** Advertising on exposed parts of Players' bodies is prohibited.
- 89.9** It is allowed to place advertising on the score/video board if it does not infringe their operation and visibility of information related to staging of the Championship Match.



VTB UNITED LEAGUE REGULATIONS

SEASON 2020-2021

- 89.10** Clubs shall use images of Players and Club representatives in printed materials and outdoor advertising, in the official Clubs websites and their accounts in social media or in any other mass media, on equipment approved by the League and with the League official ball. It is not allowed to use image of the logo of another League on the equipment and any other brands of the ball except for the Official ball of the League.

For violation, a fine of one hundred thousand (100,000) RUB is imposed on the Club.

ARTICLE 90 LEAGUE INTERNET SHOP

- 90.1** The League shall develop and support activity of the League internet shop with the aim of promotion.
- 90.2** Conditions of cooperation between the League and the Clubs shall be specified by the agreements concluded separately with the aim to support of the League internet shop.

ARTICLE 91 MEDIA DAY

- 91.1** The League together with Clubs shall conduct the Media Day for producing photos, videos and other materials meeting requirements of the League.
- 91.2** Media day shall be held no later than two weeks before the start of the Regular Championship.
- 91.3** The Club shall appoint the employee responsible for the Media Day and communicate his/her contacts to the League to coordinate all activities.
- 91.4** The Club shall provide the League with an official letter with three (3) possible dates for the Media Day no later than August 13, 2020. The schedule of Media Days will be provided by the League no later than August 24, 2020. Clubs that hold a Media Day in other tournaments will agree on the date of a single Media Day with the League.
- In case of violation of this clause, a fine in the amount of one hundred thousand (100,000) RUB is imposed on the Club.**
- 91.5** The League will arrange photo and video shooting on their own and their expense. The list of necessary equipment and requirements for shooting conditions is agreed upon between the League and the Clubs separately.
- 91.6** To participate in the Media Day, the entire team and coaching staff of the Club shall be available for five hours in a row.
- 91.7** Color of playing uniform of all Players for Media Day shall be agreed with the League and the Club when they agree on the date of the Match. Playing uniform shall be available throughout the day.
- 91.8** Any training planned for the same day shall be held after the end of all activities related to Media Day.
- 91.9** Copyright for the materials of the main photo shoots and video shootings belong to the League.
- 91.10** All interviews are conducted in English or Russian. In case the interviewee does not speak English or Russian, the Club provides a translation of the interview.
- 91.11** Clubs inform all departments involved in the preparation of the media day (coaching staff, marketing, media department, management), logistical support of the event and related activities.
- 91.12** In case of additional registration of a new Player after the Media Day, the League reserves the right to request photos, interviews, and videos of such a Player made in accordance with the League's requirements to supplement the Media Day's database. The Club shall independently photograph such a Player in accordance with the requirements of the League and provide the League with at



VTB UNITED LEAGUE REGULATIONS

SEASON 2020-2021

least ten (10) different photos of the Player no later than twenty-four (24) hours before the start of the Match in which this Player will participate.

For violation, a fine of one hundred thousand (100,000) RUB is imposed on the Club.

- 91.13** Clubs shall assist in establishing contacts with former players and coaches or other public persons for interviews within the framework of the Media Day.
- 91.14** Clubs shall announce and cover the course of the Media Day in local and social media.
- 91.15** The League reserve the right to request a special interview with two Players outside of the sports facility beyond time frame planned for the Media Day. If there is no possibility to organize special interview, the Club shall suggest alternative options for such an interview. Club has the right to refuse such an interview organized outside of the sports facility.
- 91.16** Clubs can plan parallel media events on the same day, however, photo and video filming by the League takes precedence over other activities. In cases when Clubs organize a unique Media Day for two tournaments, schedule and propriety of activities shall be agreed between the League and Clubs.

ARTICLE 92 ALL-STAR GAME. OTHER ACTIVITIES.

- 92.1** The League has the right to organize and conduct various official and demonstration events that correspond to its statutory goals, for example, the All-Star Game with the participation of players of clubs participating in the Championship.
- 92.2** The League has all the rights to the All-Star Game, other similar events, including (but not limited to) exclusive rights to television, marketing, licensed and advertising rights. The League freely disposes of these exclusive rights, which, among other things, provides for the possibility of delegating such rights to clubs / teams or third parties.
- 92.3** The League can delegate to another organization in full or in part the right to hold an All-Star Game.
- 92.4** The order of the management, filing of applications and other conditions of the All-Star Game are governed by the Regulations or the Regulations for holding an All-Star Game, approved by the President of the League and the General Director of the League.
- In the event the League organizes an All-Star Game, all Clubs/teams are required to ensure the participation of Players and Coaches of their teams summoned to the All-Star Game. If a Player or a Coach invited to an All-Star Game fails to take part, the Club that this Player or Coach is registered with in the Club's passport, has to document a justified reason for not appearing at the All-Star Game. If the reason of no show to the Match of All Stars is injury/illness, this Player or Coach of the League must undergo additional examination by independent Doctor chosen by the League.
- If there is no justified reason, a fine will be imposed on the Club in the amount of five hundred thousand (500,000) RUB.**
- 92.5** The rights, organization and conditions for holding other official League events, which may be held in the future, are regulated similarly as staging of the All-Star Game.



VTB UNITED LEAGUE REGULATIONS

SEASON 2020-2021

ANNEX No. 1



ТЕХНИЧЕСКАЯ ЗАЯВКА НА МАТЧ TEAM LIST FOR GAME

КЛУБ/ CLUB:		
Дата/ Date:	Команда-хозяин/ Home team:	Команда-визитер/ Visiting team:
№ Игры/ Game #:		

№	Номер игрока/ Player's number	Лицензия/ License	Фамилия, имя игрока/ Surname, name of player
1			
2			
3			
4			
5			
6			
7			
8			
9			
10			
11			
12			
<i>Отметить капитана (КАП) /Mark captain (cap.)</i>			
13	Тренер/ Coach		
14	Помощник тренера/ Assistant coach		
15	Представитель команды на матче/ Team representative for current game		
16	Сопровождающее лицо/ Team follower		
17	Сопровождающее лицо/ Team follower		
18	Сопровождающее лицо/ Team follower		
19	Сопровождающее лицо/ Team follower		
20	Сопровождающее лицо/ Team follower		
21	Сопровождающее лицо/ Team follower		

Цвет формы/ Uniform color: _____

* Врач Клуба /Club's Doctor: _____

Фамилия/ Surname
Имя /Name
подпись /signature

** Настоящим подтверждаю, что игроки не имеют медицинских противопоказаний для участия в данном Матче.*

** Herby I confirm that players do not have contradictions to participate in current Game.*

Подпись Представителя команды на матче/ Signature of team representative for current game _____



VTB UNITED LEAGUE REGULATIONS

SEASON 2020-2021

ANNEX No. 2

CLUB'S INFORMATION FORM

Club (full name):

(short name for the site):

(short name for TV with 3–4 letters):

City:

Main sports facility (name):

Address:

Reserve sports facility (name):

Address:

Address of the Club (legal):

Address of the Club (actual):

Phone, e-mail:

Head of the Club (full name, position, e-mail):

Sports Department (full name, position, e-mail):

Accounting Department (full name, position, e-mail):



VTB UNITED LEAGUE REGULATIONS

SEASON 2020-2021

Legal Department (full name, position, e-mail):

Employee responsible for conducting matches (full name, position, e-mail):

Employee responsible for interacting with the TV partner of the League and Club

(Full name, position, e-mail):

Employee responsible for maintaining statistics (full name, position, e-mail):

Public relations officer (full name, position, e-mail):

Employee responsible for the official website (full name, position, e-mail):

Employee responsible for social media accounts

(Full name, position, e-mail):

Photographer/specialist of the photo service (full name, position, e-mail):

Responsible for marketing (full name, position, e-mail):

Responsible for the ticket program (full name, position, e-mail):

Head of the security staff (full name, position, e-mail):



VTB UNITED LEAGUE REGULATIONS SEASON 2020-2021

ANNEX No. 3

CERTIFICATE OF COMPLIANCE OF A SPORTS FACILITY WITH THE REQUIREMENTS OF THE VTB UNITED LEAGUE CHAMPIONSHIP REGULATIONS FOR THE 2020–2021 SEASON

City of _____

_____ 2020

Basketball club (full name of the legal entity): _____

Basketball team (team name): _____

Sports facility (main / reserve): _____

Address: _____

Owner: _____

Grounds for using a sports facility by a Club (document, its number, date of signing, validity period): _____

Year of commissioning: _____

Date of major repairs: _____

- | | | |
|----|-------------------------------------------------------------------------------------------------------------------------------------------------------------------------------------------------------------|----------------------------|
| 1 | Number of seats. | _____ |
| 2 | The Playing court measures 28 m long x 15 m wide. | YES / NO |
| 3 | Any obstacles, including the team bench, are at least 2 meters away from the playing court. | YES / NO |
| 4 | The covering of the playing court.
- manufacturer company
- brand (model)
- year and month of commissioning
- year and month of last repair
- total size of the covering | Stationary/
demountable |
| 5 | The marking of the playing court follows the FIBA Official Basketball Rules. Lines marking the Playground are of the same color, painted in white or another contrasting color with a width of 5 cm. | YES / NO |
| 6 | On the playing court there is an additional limiting line of sharply contrasting color, which has a width of at least 2 meters. | YES / NO |
| 7 | The playing court is evenly and sufficiently lit – 2,000–2,500 Lux. | YES / NO |
| 8 | Availability of an Autonomous power supply system for lighting. | YES / NO |
| 9 | The height of the ceiling or the distance to the lower barrier above the surface of the platform must be at least 7 meters. | YES / NO |
| 10 | The sports facility has a thermometer, luxometer, hygrometer, and pressure gauge. | YES / NO |
| 11 | The supports of the backboard have fasteners that prevent any movement under the influence of loads during the game and meet the requirements of the FIBA Official Basketball Rules – Basketball Equipment. | YES / NO |



VTB UNITED LEAGUE REGULATIONS

SEASON 2020-2021

- quantity _____
- manufacturer company _____
- brand (model) _____
- year and month of commissioning _____
- 12 The padding of the backboard's support is no closer than 2 meters from the outer edge of the front line. YES / NO
- 13 The backboard and its support are covered with padding. YES / NO
- 14 The backboards are made of a solid, hardened, unbreakable piece of glass with a secure structure (which does not form sharp fragments when destroyed), framed in a rigid metal frame, and have dimensions of 1800 mm (+maximum of 30 mm) x 1050 mm (+maximum of 20 mm), meet the requirements of the FIBA Official Basketball Rules – Basketball Equipment. YES / NO
- quantity _____
- manufacturer company _____
- brand (model) _____
- year and month of commissioning _____
- 15 The backboard, along its perimeter, is equipped with light devices attached to the inner borders of the backboards and light up in red when the game clock sounds the end of the quarter. YES / NO
- The backboard is equipped with a light device attached to the top of the backboard and lights up yellow when the shot clock sounds.
- 16 The rings are made of solid steel and meet the requirements of the FIBA Official Basketball Rules – Basketball Equipment. YES / NO
- quantity _____
- manufacturer company _____
- brand (model) _____
- year and month of commissioning _____
- 17 The nets are made of white cord and meet the requirements of the FIBA Official Basketball Rules – Basketball Equipment. YES / NO
- quantity (including spare) _____
- manufacturer company _____
- brand (model) _____
- year and month of commissioning _____
- 18 A sports facility is equipped with at least one (1) spare backboard's support and one (1) backboard, fully equipped and ready for quick replacement of damaged equipment. YES / NO
- location of the spare support during the match _____
- 19 The Host Club has all the necessary tools and personnel at its disposal for quick replacement (no more than 30 minutes) of damaged equipment specified in article 13 of the Regulations. YES / NO



VTB UNITED LEAGUE REGULATIONS

SEASON 2020-2021

20	All rows and seats in the tribunes for spectators are numbered.	YES / NO
21	Spectator seats are located at least 2 meters from the outer edge of the bounding lines of the playing court. The location of spectator seats corresponds to Annex 13.	YES / NO
22	The referee's table is at least 6 meters long and 80 cm high and is located on a platform at least 20 cm high. The referees' table shall be positioned so that its center on the long side coincides with the central line of the marking of the playing court.	YES / NO
23	The team bench area is located on the side of the referees' table and is defined between the 5-meter line and the 2-meter extension of the corresponding front line.	YES / NO
24	Within the areas of the team benches, there are seats or benches with backs for at least 16 seats.	YES / NO
25	Benches with backs or chairs with backs for teams are located at a distance of at least two (2) meters from the audience.	YES / NO
26	The number of high-resolution color video screens.	
27	There is a video cube that consists of at least four high-resolution video screens and is placed above the center of the playing court.	YES / NO
28	There are two scoreboards/video panels that meet the requirements of the FIBA Official Basketball Rules – Basketball Equipment.	YES / NO
29	Video screens are combined with the scoreboard/video panel.	YES / NO
30	Scoreboard/ video panel includes and/or demonstrates: <ul style="list-style-type: none">- game clock with digital countdown in the format of minutes and seconds (mm:ss), as well as accurate to tenths (1/10) of a second only during the last minute of a quarter or overtime;- points scored by each team;- the total number of points scored by each individual player;- number of each individual player (in order 00, 0, 1, 2, 3, 4, 5, 6, 7, 8, 9, 10 and 11–99), as well as their respective surnames. To display the last name of each player on the scoreboard there are at least twelve (12) characters; team names. To display the name of each team on the scoreboard, there are at least three (3) characters;- the number of fouls committed by each team player, from 1 to 5. <p>This number is shown by five (5) indicators or numbers with a height of at least 135 mm. The fifth foul is marked in red or orange. In addition, the 5th foul is indicated by a slow-flashing indicator (~ 1 Hz) for five (5) seconds. The scoreboard / video panel displays team fouls regardless of the players' fouls;</p> <ul style="list-style-type: none">- the number of team fouls from 1 to 4, as well as the square that <p>marked in red after the 4th team foul and appears in place of the number 4 after the 4th team foul at the start of the game clock. The size of the red square in the range from 80% to 120% of the width of the digit 4;</p> <ul style="list-style-type: none">- quarter number from 1 to 4 and "O" for overtime;- the number of requested timeouts from 0 to 3;- clock for timing a time-out.	YES / NO YES / NO YES / NO YES / NO YES / NO
31	The game clock meets the requirements of the FIBA Official Basketball Rules – Basketball Equipment.	YES / NO



VTB UNITED LEAGUE REGULATIONS

SEASON 2020-2021

- 32 There is a device for automatically stopping time on the whistle, synchronized with the game clock and corresponding to article 13 of the FIBA Official Basketball Rules – Basketball Equipment. YES / NO
- quantity _____
- manufacturer company _____
- brand (model) _____
- 33 The operation data of the automatic stop time devices on the whistle at the Match is saved in a format that displays the stop/start time of the game clock/ shot clock by each referee and the referee-secretary at the Match. YES / NO
- 34 There is a digital shot clock that corresponds to the FIBA Official Basketball Rules – Basketball Equipment. YES / NO
- quantity _____
- manufacturer company _____
- brand (model) _____
- year and month of commissioning _____
- number of displays for each device _____
- availability of a shot clock on the spare support _____
- 35 There are two independently distinct loud signals available, one for the stopwatch and sounds automatically at the end of game time, as well as in manual mode, the other, provided to the shot clock operator, sounds automatically. YES / NO
- 36 The sound volume corresponds to 120 decibels, measured at a distance of 1 meter from the sound source. YES / NO
- 37 The audio signals are connected to the sound-amplifying equipment of the sports facility. YES / NO
- 38 There is a microphone for the speaker/presenter, sound-amplifying equipment and a speaker system. YES / NO
- 39 There is a backup set of the following equipment that meets the requirements of the Regulations: YES / NO
- scoreboard;
- 40 - shot clock.
- Internet access is provided:
- at least one (1) dedicated line (wired connection) with a guaranteed bandwidth of at least ten (10) Megabits / s on the referees' table; YES / NO
- WI-FI connection with a speed of at least five (5) Megabits/s per 1 (one) connection or cable connection at a speed of at least five (5) Megabits/s per one (1) connection in the media work area next to the playing court (press stand), in the press conference room and in the press center. YES / NO
- 41 There is an advertising structure located on the perimeter of the playing court and consisting of led screens (LED screen), which meets the requirements of Chapter 12 of these Regulations and article 15 of the FIBA Official Basketball Rules – Basketball Equipment. YES / NO
- quantity _____
- manufacturer company _____



VTB UNITED LEAGUE REGULATIONS

SEASON 2020-2021

- brand (model) _____
 - year and month of commissioning _____
 - number of displays for each device _____
- 42 All components of LED screens meet the safety requirements, do not cause inconvenience to the participants of the Match when entering the court and exclude the possibility of injury to the participants of the Match. LED screens have: YES / NO
- screen without protruding elements;
 - soft padding on top and sides;
 - securely secured protective back panel.
- 43 At the disposal of the referees-secretaries is provided:
- two (2) control stopwatches; YES / NO
 - five (5) pointers of player fouls (article 7 of the FIBA Official Basketball Rules – Basketball Equipment); YES / NO
 - two (2) team foul pointers (article 8 of the FIBA Official Basketball Rules – Basketball Equipment); YES / NO
 - one (1) pointer (arrow) of the order of possession (article 9 of the FIBA Official Basketball Rules – Basketball Equipment); YES / NO
 - computer equipment and equipment with a cable connection to the Internet for conducting Match statistics, online text broadcasting of the Match and printing statistical reports (paragraph 47.2 of article 47 of these Regulations); YES / NO
- 44 The following premises are available that meet the requirements of this Regulation and are locked with a key:
- equipped locker rooms for teams (pcs) _____
 - equipped changing rooms for Coaches (pcs) _____
 - equipped locker room for Judges, Commissioner and Official Delegate-Inspector; YES / NO
 - equipped locker room for the team of referees-secretaries; YES / NO
 - first aid points for Players and spectators,
other participants of the match (medical points) (pcs) _____
 - doping control room; YES / NO
 - rooms for VIP guests (pcs) YES / NO
 - press conference room; YES / NO
 - press center (working room for the press); YES / NO
 - availability of a sufficient number of equipped seats for accredited journalists (press tribune). YES / NO
- 45 The sports facility and the surrounding area meet the requirements of the Regulations for the production and transmission of television signal matches:
- availability of connection of the sports facility to the fiber-optic communication line used by the TV partner of the League or the Club; YES / NO
 - it is possible to place the receiving and transmitting equipment connected to the fiber-optic communication lines of the TV partner of the League; YES / NO



VTB UNITED LEAGUE REGULATIONS

SEASON 2020-2021

- a place was provided for parking fire-fighting technical equipment and television equipment and ensuring its safety; YES / NO
 - it is possible to place television equipment in a sports facility (stationary machines, cameras, commentator positions, equipment for computer registration of broadcasts, etc.); YES / NO
 - it is possible to make the necessary connections to the power supply of the sports facility; YES / NO
 - it is possible to use embedded television communications. If there are none, it is possible to lay the necessary TV cables; YES / NO
 - it is possible to access the premises of the sports facility necessary for television video shooting; YES / NO
 - availability of a dedicated Internet access channel for the needs of PTS with a bandwidth of at least 100 Mbit/s; YES / NO
 - the presence or possibility of constructing platforms for the installation of a leading television camera and a camera for enlarging and
unhindered laying of low-current and power cables to them; YES / NO
 - operation of two independent power supply sources is ensured; YES / NO
 - it is possible to organize a commentator's position.
- 46 The sports facility is equipped with a video surveillance system that allows the identification of individuals during their stay in the competition venues with the ability to store information for at least one month YES / NO



VTB UNITED LEAGUE REGULATIONS

SEASON 2020-2021

The following documents are attached to this certificate:

- extract from the unified state register of real estate about the owner of a sports facility;
- a document confirming the commissioning of the sports facility;
- technical passport of a sports facility (with the number of spectator seats in the sports facility);
- sports facility security passport developed in accordance with the Federal Law "On counteracting terrorism" and Decree of the Government of the Russian Federation dated March 6, 2015 No. 202 "On approving the requirements for anti-terrorist protection of sports facilities and the form of a sports facility security passport" (for Russian clubs);
- sports facility security passport, instructions for ensuring public order and public safety at the sports facility and an action plan for ensuring public order and public safety during Championship Matches (for Russian Clubs);
- sports facility security passport, rules/instructions for ensuring public order and public safety at the sports facility or other documents on security during the Championship Matches in accordance with the requirements of the legislation of the country of the Foreign Club (for Foreign Clubs);
- fire and explosion safety instructions;
- instructions for compliance with safety regulations for all kinds of technical services;
- job descriptions for employees responsible for compliance with technical operation rules;
- license to carry out medical activities by a medical center and instructions (rules) on medical support;
- the layout of location of evacuation signs of safety; the layout of location of health centers; the layout of rooms or specially equipped places for storage of items forbidden to be brought; the scheme of organization of traffic of pedestrians and vehicles in the competition venue and the surrounding areas;
- rules of behavior of spectators in a sports facility;
- layout of spectator seats in the stands divided by sectors, indicating the number of rows and spectator seats in each sector. The layout shall indicate the sectors for active support of the Host and Guest Clubs and the number of seats in this sector.

We, the undersigned, have drawn up this Certificate stating that this sports facility has the characteristics and equipment described above and meets the requirements of the VTB United League Championship Regulations for the 2020–2021 season for holding Championship Matches.

Head of the Club (full name, position, e-mail):

Head of the Owner (balance holder) of a sports facility (full name, position, signature, seal):

The Head or official responsible for the operation of engineering systems and sports facilities in general (full name, position, signature, seal):

PLAYING UNIFORM LAYOUT

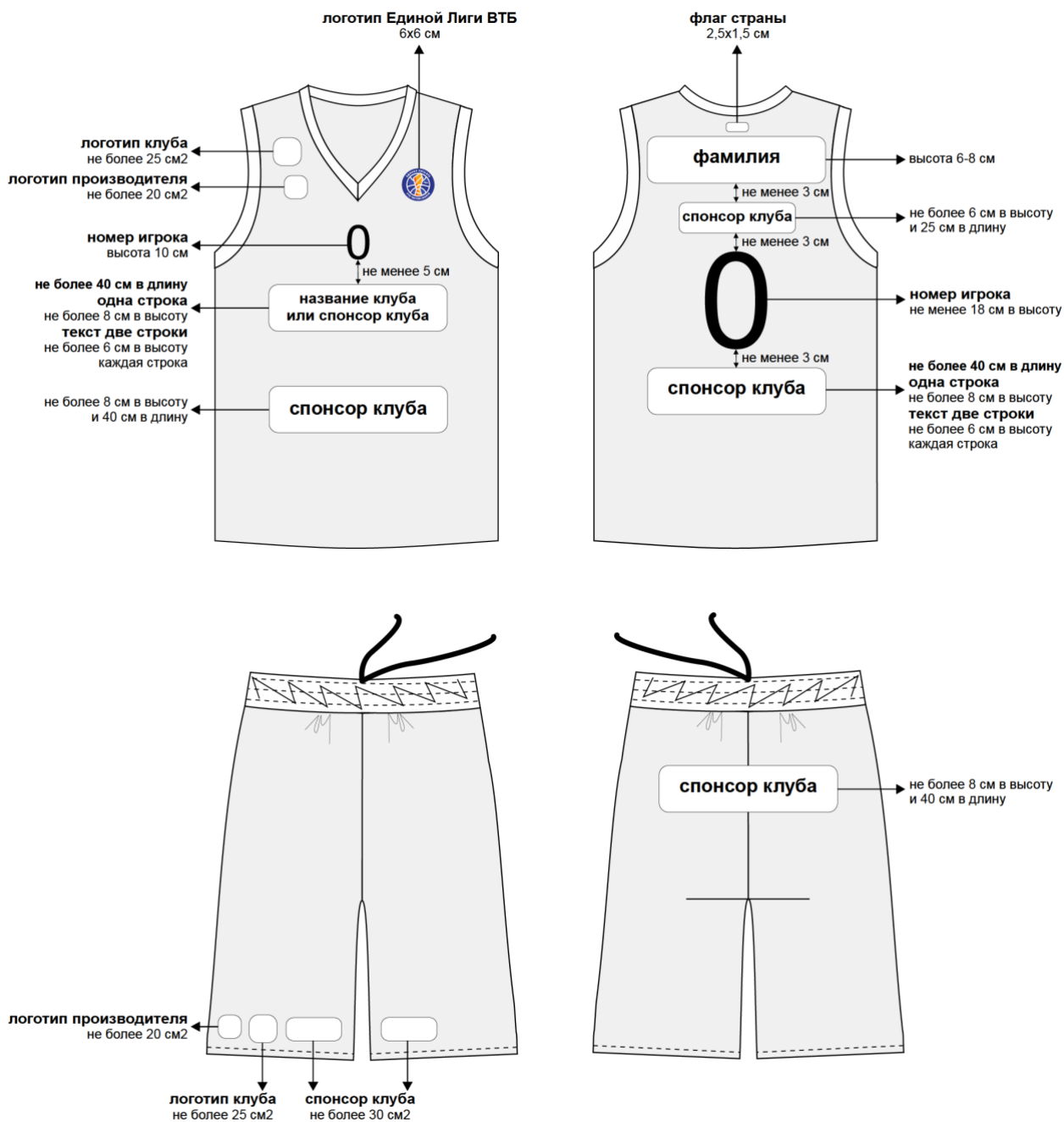



VTB UNITED LEAGUE REGULATIONS

SEASON 2020-2021

логотип Единой Лиги ВТБ 6x6 см	VTB United League logo 6x6 cm
логотип клуба не более 25 см ²	Club logo no more than 25 cm ²
логотип производителя не более 20 см ²	manufacturer's logo no more than 20 cm ²
номер игрока высота 10 см	Player's number height 10 cm
не более 40 см в длину одна строка не более 8 см в высоту	no more than 40 cm in length one line no more than 8 cm in height
текст две строки не более 6 см в высоту каждая строка	two lines of text no more than 6 cm in height for each row
не более 8 см в высоту и 40 см в длину	no more than 8 cm in height and 40 cm in length
не менее 5 см	at least 5 cm
название клуба или спонсор клуба	Club's name or the Club's sponsor
спонсор клуба	Club's sponsor
флаг страны 2,5x1,5 см	country flag 2.5x1.5 cm
высота 6-8 см	height 6–8 cm
не более 6 см в высоту и 25 см в длину	no more than 6 cm in height and 25 cm in length
номер игрока не менее 18 см в высоту	Player's number at least 18 cm in height
не более 40 см в длину одна строка не более 8 см в высоту	no more than 40 cm in length one line no more than 8 cm in height
текст две строки не более 6 см в высоту каждая строка	two lines of text no more than 6 cm in height for each row
фамилия	surname
не менее 3 см	at least 3 cm
спонсор клуба	Club's sponsor
не менее 3 см	at least 3 cm
спонсор клуба	Club's sponsor
логотип производителя не более 20 см ²	manufacturer's logo no more than 20 cm ²
логотип клуба не более 25 см ²	Club logo no more than 25 cm ²
спонсор клуба не более 30 см ²	Club's sponsor no more than 30 cm ²
спонсор клуба не более 8 см в высоту и 40 см в длину	Club's sponsor no more than 8 cm in height and 40 cm in length

WARM-UP UNIFORM LAYOUT

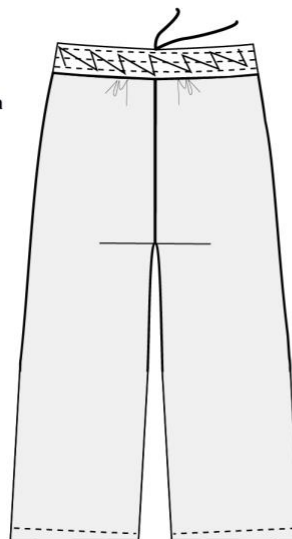
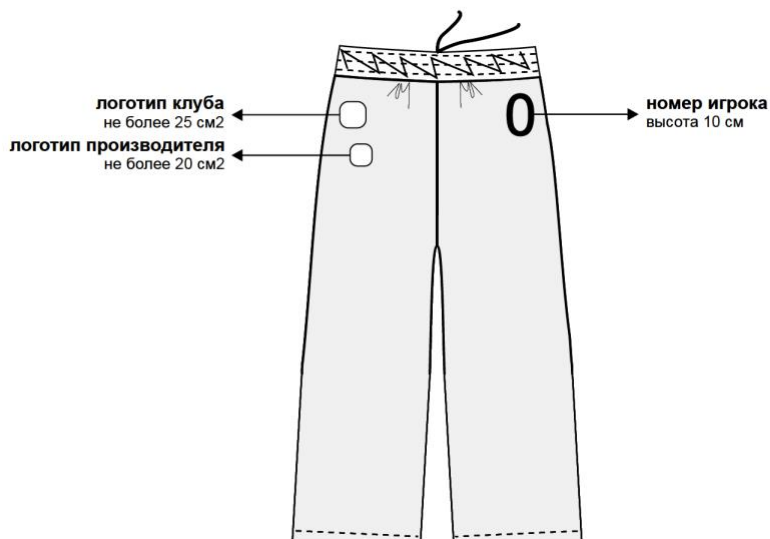



VTB UNITED LEAGUE REGULATIONS

SEASON 2020-2021

логотип клуба не более 25 см ²	Club logo no more than 25 cm ²
логотип производителя не более 20 см ²	manufacturer's logo no more than 20 cm ²
номер игрока высота 10 см	Player's number height 10 cm
не более 40 см в длину одна строка не более 8 см в высоту	no more than 40 cm in length one line no more than 8 cm in height
текст две строки не более 6 см в высоту каждая строка	two lines of text no more than 6 cm in height for each row
не более 8 см в высоту и 40 см в длину	no more than 8 cm in height and 40 cm in length
название клуба или спонсор клуба	Club's name or the Club's sponsor
спонсор клуба	Club's sponsor
не более 40 см в длину одна строка не более 8 см в высоту текст две строки не более 6 см в высоту каждая строка	no more than 40 cm in length one line no more than 8 cm in height two lines of text no more than 6 cm in height for each row
спонсор клуба	Club's sponsor
спонсор клуба	Club's sponsor
логотип клуба не более 25 см ²	Club logo no more than 25 cm ²
логотип производителя не более 20 см ²	manufacturer's logo no more than 20 cm ²
номер игрока высота 10 см	Player's number height 10 cm



VTB UNITED LEAGUE REGULATIONS

SEASON 2020-2021

ANNEX NO. 5

CLUB'S APPLICATION FORM

for participation in VTB United League Championship season 2020-2021



Club _____
(Name of club) (City)

Players

No	Surname Name (in alphabetic order)	Shirt number	Date of birth	Citizenship	Height (cm)	Weight (kg)	Shirt size (S,M,L...)	Position	Player's Signature	Doctor's admission with stamp
1										
2										
3										
4										
5										
6										
7										
8										
9										
10										
11										
12										
13										
14										
15										
16										

We, the undersigned, confirm that the players indicated in this list have had in-depth medical examination in _____ (name medical institution), do not have medical obstacles and are allowed to participate in the VTB United League Championship games season 2020-2021

Doctor of medical entity _____ (_____)
(name, surname) stamp, signature

Head of Club _____ (_____) Team's doctor _____ (_____)
(name, surname) stamp, signature (name, surname) stamp, signature

CLUB'S APPLICATION FORM

for participation in VTB United League Championship season 2020-2021



Coaches and team followers

(for those who receives license)

No	Surname Name	Date of birth	Citizenship	Position	Signature
1					
2					
3					
4					
5					
6					
7					
8					
9					
10					

Head of Club _____
(name, surname)

_____ (stamp, signature)



VTB UNITED LEAGUE REGULATIONS

SEASON 2020-2021

Note: In the application for participation in the VTB United League Championship of the 2020–2021 season, it is necessary to put a mark "admitted" next to each player's name, which is certified by the signature of a sports medicine doctor and his/her personal seal.

The application for participation in the VTB United League Championship is signed by a sports medicine doctor with a transcript of the last name, first name, patronymic (if any) and certified by the seal of a medical organization licensed to carry out medical activities that provide work (services) in physical therapy and sports medicine.

If the athlete has an individual medical report in the application, the mark "Admission from _____ (date) is available", a copy of the medical report is attached to the application.



VTB UNITED LEAGUE REGULATIONS

SEASON 2020-2021

ANNEX No. 6

LIST OF ADDITIONAL DOCUMENTS TO BE PRESENTED BY RUSSIAN CLUBS FOR LICENSING PURPOSES

When passing through the licensing for participation in the Championship, the Club presents the following documents to the Directorate:

- a copy of the employment contract between the Club and the Player registered in the RBF – one (1) copy;
- Player questionnaire in the form provided by the League;
- a copy of the national passport, which must clearly show the full name, date and place of birth, photo, and citizenship. If the Player has more than one citizenship, provide copies of all passports held by the Player;
- a letter of authorization from the former club (the last club for which the Player was declared) if there is a valid contract between the Player and the former club in the case of a domestic transfer and from the Federation of the country of his/her last club in the case of an international transfer;
- a lease agreement if a Player is temporarily transferred from one club to another;
- if the Player has more than one citizenship, one of which is the citizenship of the Russian Federation – a document issued by the RFB and authorizing the player to play for the national basketball team of the Russian Federation.

For the Coach's application, including those who do not have Russian citizenship, the following documents are submitted to the League:

- Coach's completed questionnaire on the form provided by the League;
- Copy of the civil passport, where the full name, date and place of birth, photo, and citizenship should be clearly visible

For the application of Club's Team Followers, including those who do not have Russian citizenship, the following documents are submitted to the League:

- Copy of the civil passport, where the full name, date and place of birth, photo, and citizenship should be clearly visible

ANNEX No. 7

LIGHTING OF THE PLAYING COURT

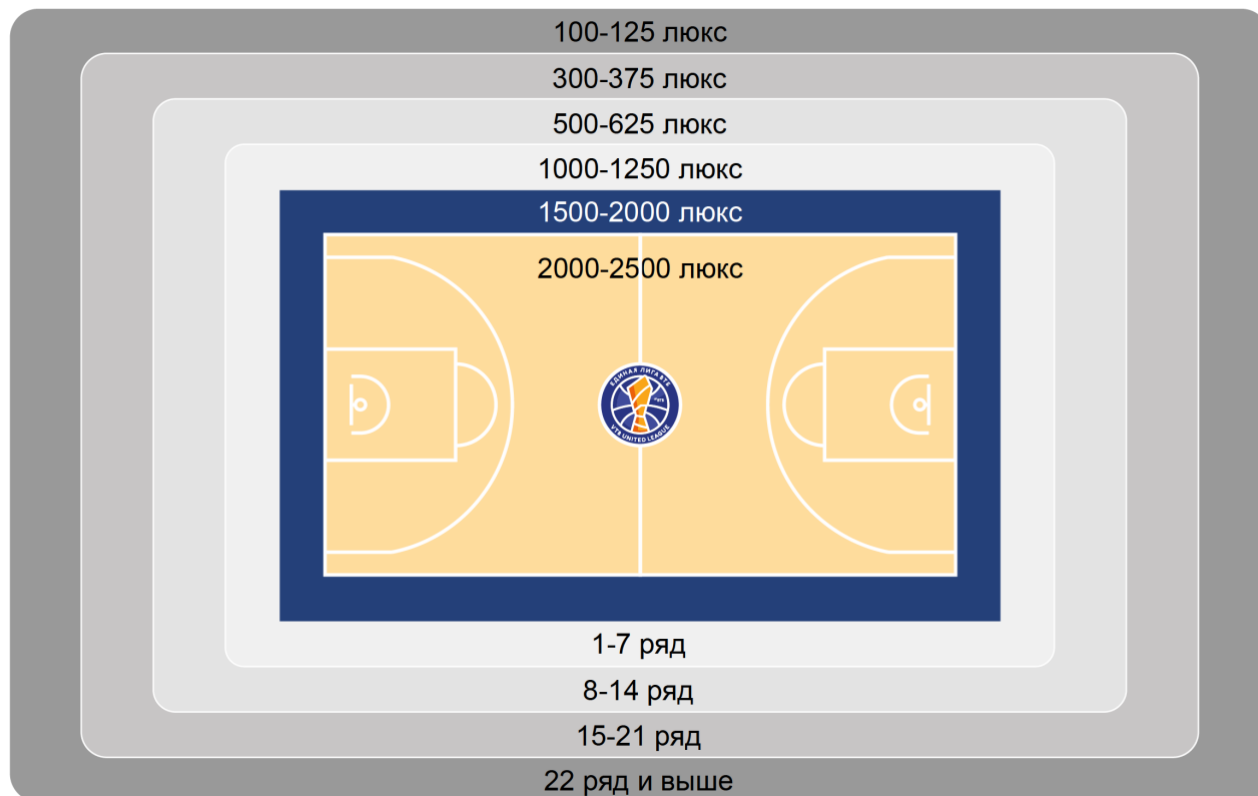

100-125 люкс	100-125 lux
300-375 люкс	300-375 lux
500-625 люкс	500-625 lux
1000-1250 люкс	1000-1250 lux
1500-2000 люкс	1500-2000 lux
2000-2500 люкс	2000-2500 lux
1-7 ряд	1-7 row
8-14 ряд	8-14 row
15-21 ряд	15-21 row
22 ряд и выше	22 row and higher

PLAYING COURT LAYOUT

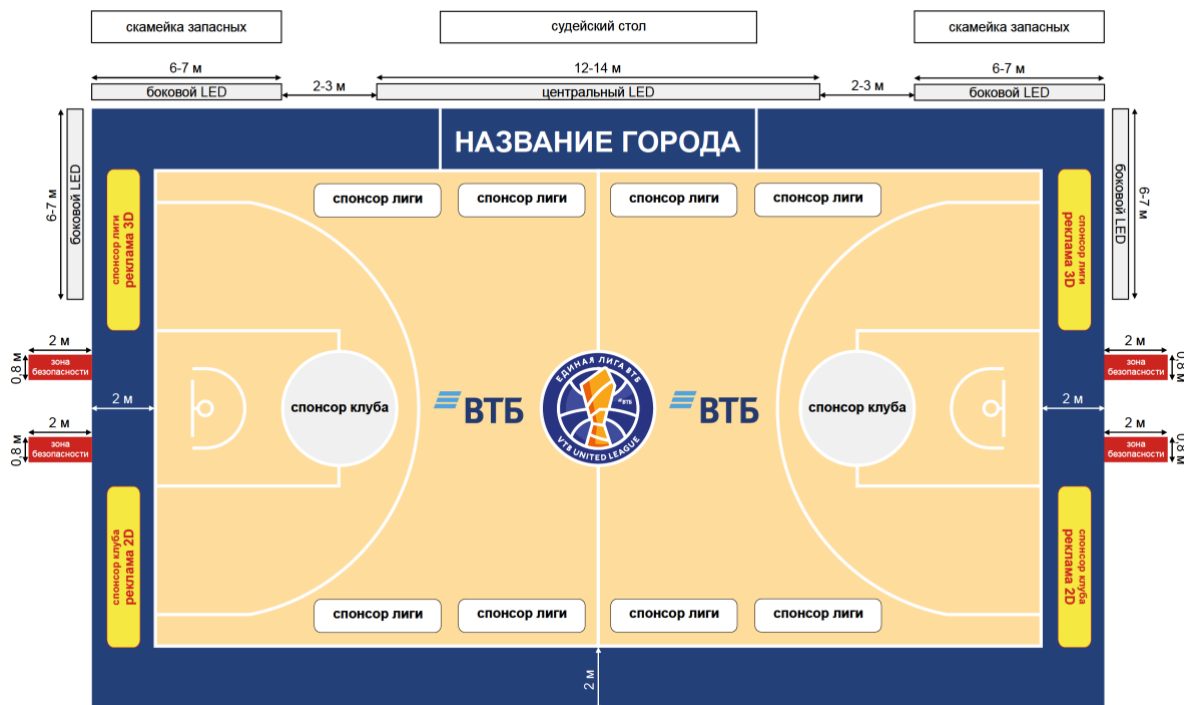

скамейка запасных	substitutes' bench
судейский стол	judges' table
боковой LED	side LED
центральный LED	central LED
НАЗВАНИЕ ГОРОДА	CITY NAME
спонсор лиги	League's sponsor
спонсор лиги реклама 3D	League's sponsor 3D advertising
зона безопасности	security zone
спонсор клуба	Club's sponsor
спонсор лиги реклама 2D	League's sponsor 2D advertising

PLACING ADVERTISING MATERIALS ON THE SUPPORT OF THE BACKBOARD, BACKBOARD AND RING

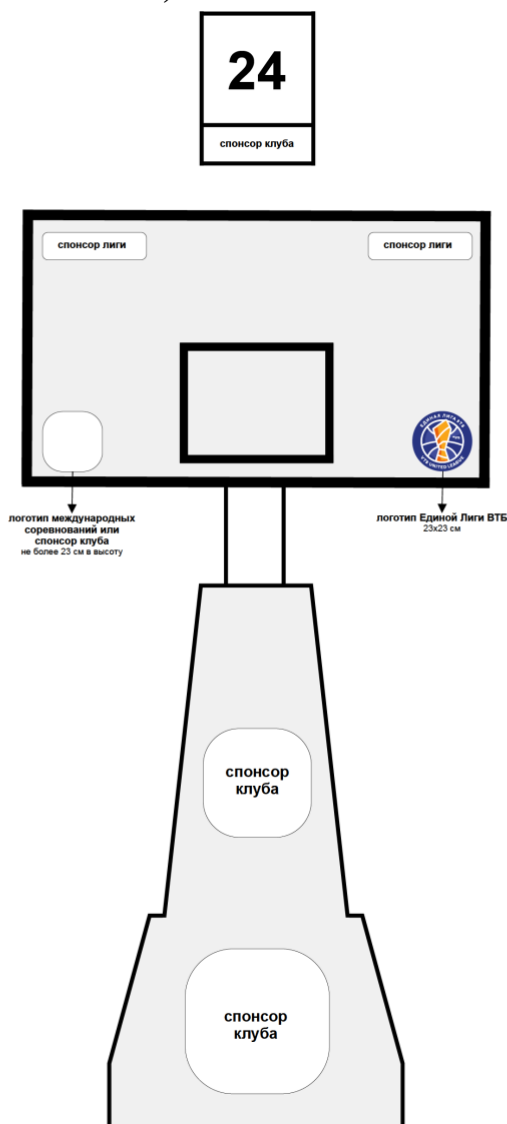

спонсор клуба	Club's sponsor
спонсор лиги	League's sponsor
логотип международных соревнований или спонсор клуба не более 23 см в высоту	logo of international competitions or club sponsor no more than 23 cm in height
логотип Единой Лиги ВТБ 23x23 см	VTB United League logo 23x23 cm



VTB UNITED LEAGUE REGULATIONS

SEASON 2020-2021

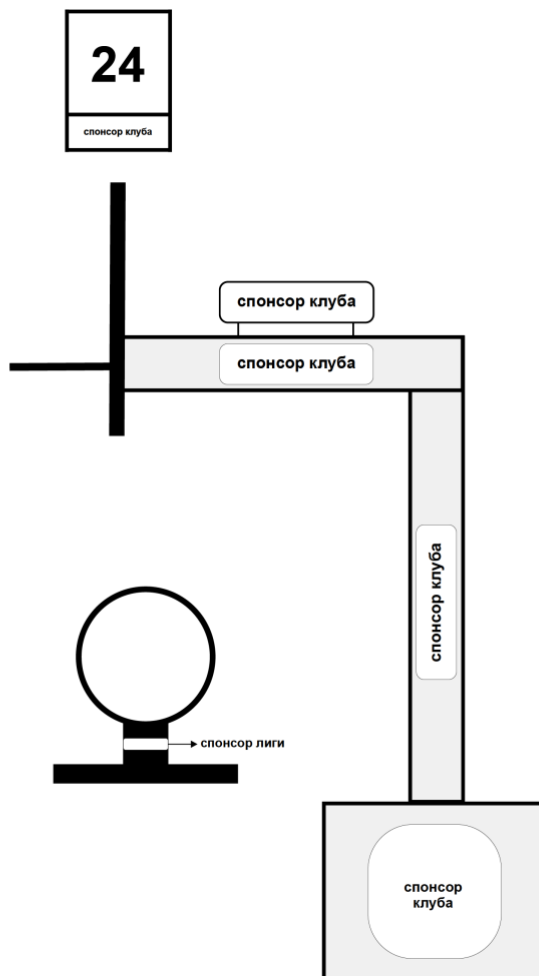

спонсор клуба	Club sponsor
спонсор лиги	League sponsor



VTB UNITED LEAGUE REGULATIONS

SEASON 2020-2021

ANNEX No. 9

PARTICIPANTS OF THE CHAMPIONSHIP

1. Avtodor BC (Saratov, Russian Federation)
2. Astana PBC (Nur-Sultan, Republic of Kazakhstan)
3. Enisey BC (Krasnoyarsk, Russian Federation)
4. Zenit BC (St. Petersburg, Russian Federation)
5. Stelmet Enea Zielona Gura BC (Zielona Gura, Republic of Poland)
6. Kalev BC (Tallinn, Republic of Estonia),
7. Lokomotiv-Kuban PBC (Krasnodar, Russian Federation),
8. Nizhny Novgorod BC (Nizhny Novgorod, Russian Federation),
9. PARMA BC (Perm, Russian Federation)
10. UNICS BC (Kazan, Russian Federation)
11. Khimki BC (Khimki, Russian Federation)
12. Tsmoki-Minsk BC (Minsk, Republic of Belarus)
13. CSKA PBC (Moscow, Russian Federation)



VTB UNITED LEAGUE REGULATIONS

SEASON 2020-2021

ANNEX No. 12

CERTIFICATE ON SAFETY AT THE MATCH

Match No. _____ Date « _____ »

The Host Team _____ The Guest Team _____

Sport facility _____

No.	NAME
1.	Head of Security Headquarters (representative of the Host Club) (Full name):
2.	Representatives of the Ministry of Internal Affairs in the staff (Full name, military rank):
3.	Representatives of the Ministry of Civil Defense in the staff (Full name, military rank):
4.	Representatives of the Private Security Company/Security Service in the staff (Full name):
5.	Representative of the Supervision and Auditing Service (Full name):
6.	Number of officers of the Ministry of Internal Affairs ensuring safety at the game _____ persons
7.	Number of officers of the Ministry of Civil Defense ensuring safety at the game _____ persons
8.	Number of officers of the Private Security Company/Security Service ensuring safety at the game _____ persons
9.	Total number of employees ensuring safety for the game _____ persons
10.	Total number of spectators at the game _____ persons
11.	Presence of: - emergency medical setting; YES/NO - a medical doctor in the hall. YES/NO
12.	Fire protection station YES/NO
13.	Security of the zone for honored guests _____ persons
14.	Security of the Commissioner of the game and Officiating Crew from the arrival until the departure _____ persons
15.	Security of the Commissioner of the game, scorer's table and Officiating Crew in the hall during the game _____ persons
16.	Security of teams in the hall during the game _____ persons
17.	Security of changing rooms of playing teams _____ persons
18.	Security of changing rooms of the Commissioner of the game and Officiating Crew _____ persons
19.	Security of the playing court _____ persons
20.	Security of tribunes for the audience _____ persons
21.	Security of places for the media and press conferences _____ persons
22.	Security of parking _____ persons



VTB UNITED LEAGUE REGULATIONS

SEASON 2020-2021

Violations and accidents during the events (yes/no, if yes, then give a detailed description of an accident and its causes)

Representative of the Guest Club _____	Full name _____	signature _____
_____, 20__	Time _____	hours _____ min.
Representative of the Host Club _____	Full name _____	signature _____
_____, 20__	Time _____	hours _____ min.
Commissioner of the Game _____	Full name _____	signature _____
_____, 20__	Time _____	hours _____ min.
Head of Security Staff _____	Full name _____	signature _____
_____, 20__	Time _____	hours _____ min.

Note:

THE CERTIFICATE IS SIGNED NOT LATER THAN ONE HOUR AFTER THE END OF THE MATCH



VTB UNITED LEAGUE REGULATIONS

SEASON 2020-2021

ANNEX No. 13

CHAMPIONSHIP TELEVISION VIDEO AND TELEVISION PRODUCTION MANUAL

This manual contains technical requirements for the television video recording of Championship matches, the production of the television signal of such matches, and the transmission of the television signal to national and international partners of the League. Television partners of the League and Clubs are required to meet the specified technical requirements for television video recording of Championship matches, production of the television signal of such matches, and transmission of the television signal to national and international partners of the League.

All games of the Championship are classified by categories:

Category A – Games of the Championship selected by the League for broadcasting on a federal channel in Russia with the delivery of the signal of such Matches over fiber-optic communication lines and the display of the signal of such Matches to an international satellite.

Category B – Championship matches selected by the League and intended for broadcast on cable and regional TV channels and on the Internet with the delivery of the signal of such Matches over fiber-optic communication lines.

Subcategory B1 – Championship matches selected by the League and intended for broadcast on cable and regional TV channels and on the Internet with the delivery of the signal of such Matches over fiber-optic communication lines and the display of the signal of such Matches to an international satellite

Category C – Championship matches selected by the League and intended for broadcast on the Internet with the delivery of the signal of such Matches over fiber-optic communication lines.

Subcategory C1 – Championship matches selected by the League and intended for broadcast on the Internet with the delivery of the signal of such Matches over fiber-optic communication lines and the display of the signal of such Matches to an international satellite.

Technical requirements for the production of a television signal by category of Matches Technical requirements for the production and transmission of a television signal for Category at matches are determined separately for each match and are agreed with the Directorate of the Federal channel of the Russian Federation.

Technical requirements for television video filming and television signal production for Category B matches (including subcategory B1):

VIDEO

- Format – HD 1080i;
- Number of cameras – six (6) main + one (1) camera of a shot clock (24 s)
- 2 mini cameras behind the rings (optional, if technically possible);
- Lenses – 1x50/88 (if technically possible), 2x11/17, 3x17/22;
- 1 system of slow-motion video replays from four cameras, recording to the H264 hard disk (8 Mbit/s stream);
- Curtain on replays according to the League standard;
- Graphic design of broadcasts according to the League standard.



VTB UNITED LEAGUE REGULATIONS

SEASON 2020-2021

SOUND

- Number of intersound microphones is seven (7), among them:
 - 2 microphones on the rings;
 - 3 on-camera microphones
 - 3 Guns microphones
- Playback of scenes with sound;
- Reproduction of music from digital media (Mini Disk, CD, flash cards, players);
- Possibility to organize an interview – a reporter's place should be equipped with a waveguide (with the possibility of commutation: the reporter must hear the commentator, and bringing any information to the reporter) and a microphone;
- Possibility to organize a commentary place (the commentator must hear the interview);

COMMUNICATION

- 4-wire communication of the director with all operators;
- 4-wire communication of the director with a control room.

OTHER

- Alarm (Tally) on all cameras;
- Presence of an editing control room on the PTS;
- Connecting the graphical computer (key + fill);
- Monitor on the position of the reporter and on the commentary position
- Sending a signal to the equipment for viewing the video replay by the referees;
- At the request of the Host Club, copying the Match recording to the media provided by the Club.

Camera Positions relative to the playing area:

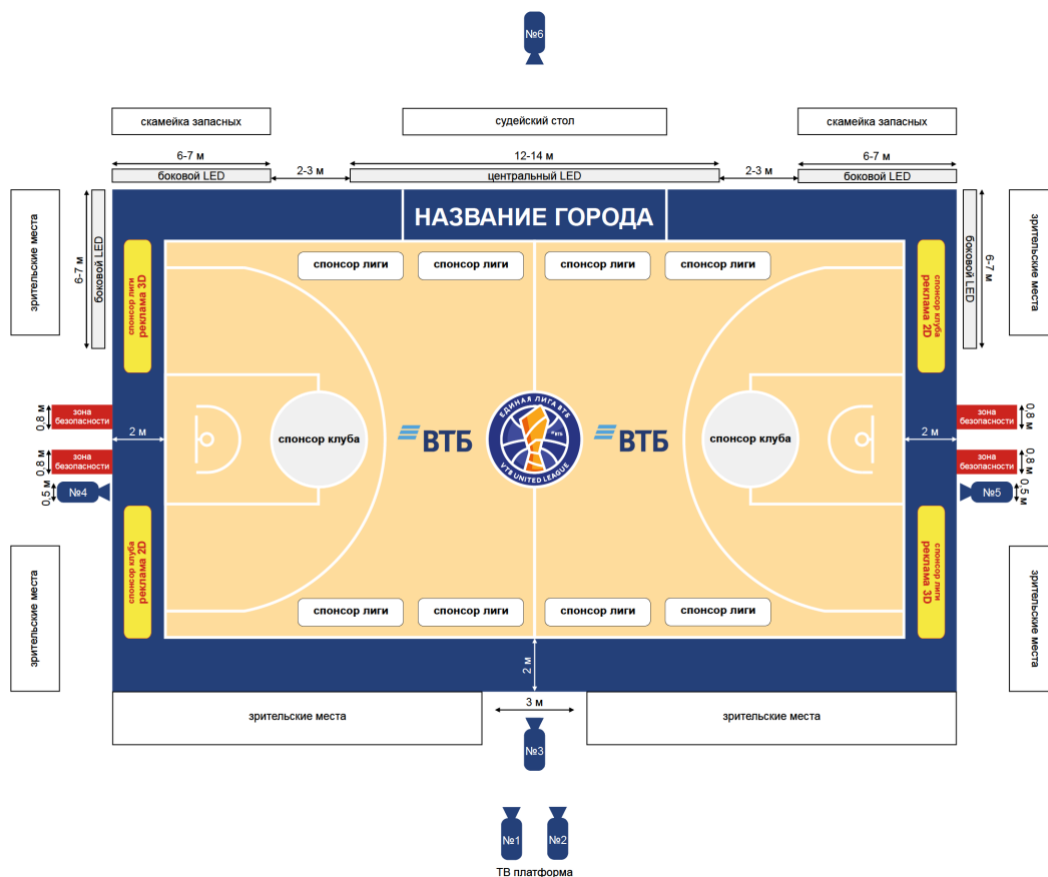

скамейка запасных	substitutes' bench
судейский стол	judges' table
боковой LED	side LED
центральный LED	central LED
НАЗВАНИЕ ГОРОДА	CITY NAME
спонсор лиги	League's sponsor
спонсор лиги реклама 3D	League's sponsor 3D advertising
зона безопасности	security zone
спонсор клуба	Club's sponsor
спонсор лиги реклама 2D	League's sponsor 2D advertising
Зрительские места	Spectator seats
ТВ платформа	TV platform

Requirements for TV video shooting:

During the "live ball", the director shall use the lead camera. Switching the cameras directly in the course of the game action is prohibited. Use of close-ups and switching cameras is allowed only during pauses of the match. Video replays in the broadcast are allowed only during pauses of the match. During the "live ball", video replays in the broadcast are prohibited. Each transition to the replay and exit from the replay is made through the official "Cutoff/Curtain".

Camera No. 1



VTB UNITED LEAGUE REGULATIONS

SEASON 2020-2021

The leading (main) camera (14x-22x) is located at an average height, strictly in the center of the basketball court opposite the team benches. The working plan of this camera is determined by several factors: visibility of the entire placement of players on the field (it is necessary to see all the players participating in the attack), presence of the time count for the attack (the scoreboard over the backboard) and the open front line of the site.

Camera No. 2

Upsizing of the leading camera (86x-101x) – located next to the camera No. 1. This camera leads the game in one and a half height, goes into the ring with the ball during the shot, and remains on a breaker during violations. During the pauses – close-ups of players on the court (heroes of the last episode), coaches and players on the benches.

Camera No. 1 and camera No. 2 are located on a stable TV platform and must have at least 2 meters of working space for each operator.

The TV platform shall be located opposite the team benches, at a height creating an angle of about 40° from the base of the TV platform and the center of the arena. The length of the platform is at least 7 meters; the width is at least 2.5 meters. In front of the platform, any objects that block the cameras zone should be absent. If the platform is not at a sufficient height, fans occupying places in the area of TV platform can block the view of cameras, then tickets must not be sold for such seats, and a security zone is created around the TV platform.

Camera No. 3

Located at the edge of the field along the centerline of the site (14-22x). In the case of equipment available for the MB, this camera can be used on a camera platform – Sports Dolly. This camera works on the “standing” game, during shots, it opens the ring without losing from the shot the player shooting the ball, and we must see the entire trajectory of the ball. After getting into the ring, the camera is enlarged to the emotion of the player.

Cameras No. 4 and No. 5

Chain cameras (14-22x). Located at the edge of the platform under the ring from the side of the leading cameras. During pre-game ceremonies, team presentations, breaks and timeouts, these cameras have the opportunity to enter the court without interfering with the players, judges and persons involved in the ceremonies. An operator's assistants must be engaged for the transfer of the cable.

One of these cameras is used for flash-interviews. Flash-interview is performed against the court near the basketball rack. During the interview, the camera should be mounted on a tripod. For flash-interviews, additional lighting equipment is required.

When fighting under the ring, the camera opens the ring itself and the players in full length. On this camera, we always must see how the ball falls into the basket. After that, the camera is enlarged on the emotions of the players. In the case of long shots, the camera escorts the ball into the ring. The last 7 seconds of attacking the opposite ring the camera holds in the shot a basketball backboard along with the scoreboard and the attacking player, not upsizing for the ball.

Camera No. 6.

The camera works from the shoulder (14-22x). Located near the players' benches. Must have a supply of cable for free movement between both benches on both sides. During players' presentation before the game, it can go to the court. During timeouts and pauses between quarters, it works with players and coaches giving instructions on the game. Long-term static plans are not allowed, panoramas on players are required, upsizing on emotions, etc. During the game, the camera works mainly on the coaches, during the substitutions follows players leaving



VTB UNITED LEAGUE REGULATIONS

SEASON 2020-2021

the court to the benches. In addition, this camera is used to shoot teams in locker rooms (in the camera chain mode) and shoot a press conference (in the camera chain mode). An operator assistant must be engaged to transfer the cable.

During timeouts, when cameras are operating near team benches, it is not permitted to broadcast background noise with the coaches' commentary.

Camera for a shot clock (24 sec. camera)

A camera without an operator. Located on a stable tripod, fixed and configured in the format for providing a live constant picture of a 24-second timer in the PTS.

Micro camera (option)

It is allowed to install additional equipment that consists of two HD micro cameras at the position on top of the baskets at an angle. In the shot there is the whole court, a ring is in the foreground. During free shots from these cameras, it is necessary to see the player.

All operators and assistants should be dressed in black jerseys to minimize attention to them when they hit the frame. All unused tripods must be hidden from the rest of the cameras, as well as the trunks from the equipment. The whole cable should be laid with smooth lines, and the undue cable should be hidden

Technical requirements for television video filming and television signal production for Category C matches (including subcategory C1):

VIDEO

- Format – HD 1080i;
- Number of cameras – four (4) main + one (1) camera of a shot clock (24 s)
- 2 mini cameras behind the rings (optional, if technically possible);
- Lenses – 4x14/22;
- 1 system of slow-motion video replays from four cameras, recording to the H264 hard disk (8 Mbit/s stream);
- Curtain on replays according to the League standard;
- Graphic design of broadcasts according to the League standard.

SOUND

- Number of intersound microphones is six (6), among them:
 - 2 microphones on the rings;
 - 2 on-camera microphones
 - 2 Guns microphones
- Playback of scenes with sound;
- Reproduction of music from digital media (Mini Disk, CD, flash cards, players);
- Possibility to organize an interview – a reporter's place should be equipped with a waveguide (with the possibility of commutation: the reporter must hear the commentator, and bringing any information to the reporter) and a microphone;
- Possibility to organize a commentary place (the commentator must hear the interview);

COMMUNICATION

- 4-wire communication of the director with all operators;
- 4-wire communication of the director with a control room.



VTB UNITED LEAGUE REGULATIONS

SEASON 2020-2021

OTHER

- Alarm (Tally) on all cameras;
- Presence of an editing control room on the PTS;
- Connecting the graphical computer (key + fill);
- Monitor on the position of the reporter and on the commentary position
- Sending a signal to the equipment for viewing the video replay by the referees;
- At the request of the Host Club, copying the Match recording to the media provided by the Club.

Camera Positions relative to the playing area:

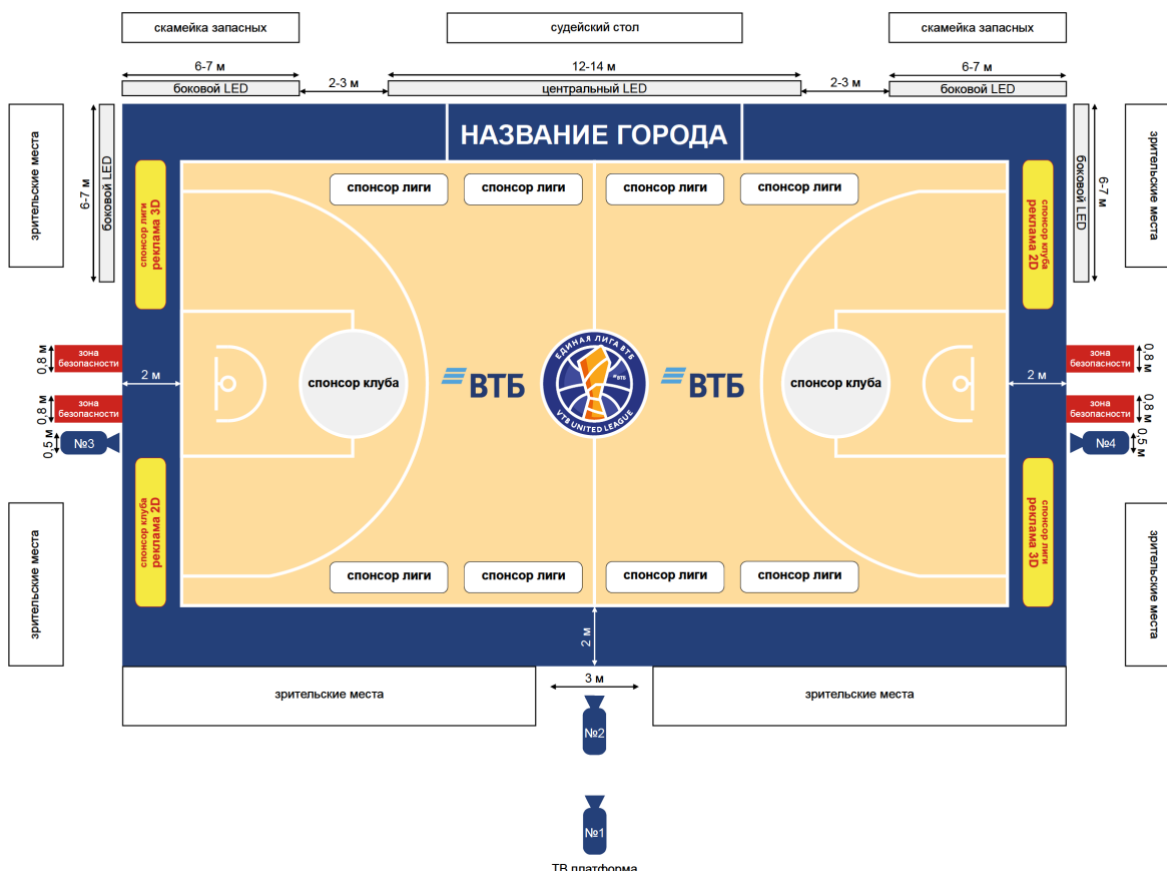

скамейка запасных	substitutes' bench
судейский стол	judges' table
боковой LED	side LED
центральный LED	central LED
НАЗВАНИЕ ГОРОДА	CITY NAME
спонсор лиги	League's sponsor
спонсор лиги реклама 3D	League's sponsor 3D advertising
зона безопасности	security zone
спонсор клуба	Club's sponsor
спонсор лиги реклама 2D	League's sponsor 2D advertising
Зрительские места	Spectator seats
ТВ платформа	TV platform

Requirements for TV video shooting:

During the "live ball", the director shall use the lead camera. Switching the cameras directly in the course of the game action is prohibited. Use of close-ups and switching cameras is allowed only during pauses of the match. Video replays in the broadcast are allowed only during pauses of the match. During the "live ball", video replays in the broadcast are prohibited. Each transition to the replay and exit from the replay is made through the official "Cutoff/Curtain".



VTB UNITED LEAGUE REGULATIONS

SEASON 2020-2021

Camera No. 1

The leading (main) camera (14x-22x) is located at an average height, strictly in the center of the basketball court opposite the team benches. The working plan of this camera is determined by several factors: visibility of the entire placement of players on the field (it is necessary to see all the players participating in the attack), presence of the time count for the attack (the scoreboard over the backboard) and the open front line of the site.

Camera No. 1 is positioned on a stable TV platform.

The TV platform should be located opposite the team benches, at a height creating an angle of about 40° from the base of the TV platform and the center of the arena. The length of the platform is at least 7 meters; the width is at least 2.5 meters. In front of the platform, any objects that block the cameras zone should be absent. If the platform is not at a sufficient height, fans occupying places in the area of TV platform can block the view of cameras, then tickets must not be sold for such seats, and a security zone is created around the TV platform.

Camera No. 2

Located at the edge of the field along the centerline of the site (14-22x). In the case of equipment available for the MB, this camera can be used on a camera platform – Sports Dolly. This camera works on the “standing” game, during shots, it opens the ring without losing from the shot the player shooting the ball, we must see the entire trajectory of the ball. After getting into the ring, the camera is enlarged to the emotion of the player.

Cameras No. 3 and No. 4

Chain cameras (14-22x). Located at the edge of the platform under the ring from the side of the leading cameras. During pre-game ceremonies, team presentations, breaks and timeouts, these cameras have the opportunity to enter the court without interfering with the players, judges and persons involved in the ceremonies. An operator's assistants must be engaged for the transfer of the cable.

One of these cameras is used for flash-interviews. Flash-interview is performed against the court near the basketball rack. During the interview, the camera should be mounted on a tripod. For flash-interviews, additional lighting equipment is required.

Camera for a shot clock (24 sec. camera)

A camera without an operator. Located on a stable tripod, fixed and configured in the format for providing a live constant picture of a 24-second timer in the PTS.

Micro camera x2 (option)

It is allowed to install additional equipment consists of two HD micro cameras at the position on top of the baskets at an angle. In the shot there is the whole court, a ring is in the foreground. During free shots from these cameras, it is necessary to see the player.

Technical requirements for transmitting a television signal at matches by displaying such a signal to a European satellite and unhindered (free) reception of this signal by the television partners of the League and Clubs. A continuous signal shall be displayed by one of the listed satellites:

EUTELSAT E7B European coverage

EUTELSAT 10A Widebeam coverage

The signal should be placed on the 9Mhz band and should correspond to the parameters 1080i 25fps, DVBS2-8PSK, H.264 MPEG 4:2:0. The signal must be encrypted with the BISS code.



VTB UNITED LEAGUE REGULATIONS

SEASON 2020-2021

A continuous signal of the game must be available on the satellite from -00:30:00 minutes before the start of the game and until + 00:15:00 minutes after the end of the game.

The signal shall contain a director's video cut of the game with graphics HD 1080p SDI embedded sound.

Audio configuration:

AUDIO:1 Intersound STEREO LEFT

AUDIO:2 Intersound STEREO RIGHT

AUDIO:3 Commentator 1

AUDIO:4 Commentator 2

In case of absence of commentators, the audio tracks remain blank.